

# Panasonic®

## DVD/CD PLAYER

### Operating Instructions



The illustration shows DVD-XP30.

Model No. **DVD-XP50**  
**DVD-XP30**



Before connecting, operating or adjusting this product, please read these instructions completely. Please keep this manual for future reference.



As an ENERGY STAR® Partner, Panasonic has determined that this product meets the ENERGY STAR® guidelines for energy efficiency.



This manual was printed with soy based ink.

### Region number supported by this player

Region numbers are allocated to DVD players and software according to where they are sold.

- The region number of this player is "1".
- The player will play DVD-Video marked with labels containing "1" or "ALL".

Example:



**For U.S.A. only**

The warranty can be found on page 26.

En la página 27 hay una guía de referencia rápida en español.

# Dear customer

Thank you for purchasing this product. For optimum performance and safety, please read these instructions carefully.

- These operating instructions are applicable to models DVD-XP50 and DVD-XP30.
- Unless otherwise indicated, illustrations in these operating instructions are of DVD-XP30.
- Operations in these instructions are described mainly with the remote control, but you can do the operations on the main unit if the controls are the same.

**XP50** : indicates features applicable to DVD-XP50 only.  
**XP30** : DVD-XP30 only.

## Accessories



Please check and identify the supplied accessories. Use numbers indicated in parentheses when asking for replacement parts.

(Only for U.S.A.)

To order accessories contact 1-800-332-5368 or web site (<http://www.panasonic.com>).

(Only for Canada)

To order accessories, call the dealer from whom you have made your purchase.

- 1 Remote control  
**XP50** (N2QAJB000063)      **XP30** (N2QAJB000037)

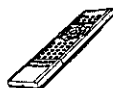

- 2 Batteries  
for remote control

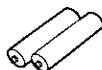

- 1 Audio/video cable  
(VJA0788)

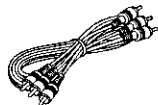

- 1 AC power supply cord  
(RJA0065-A)

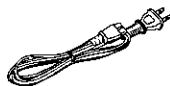

- 1 Cleaning cloth  
(RFE0088-1)



### Note

The included AC power supply cord is for use with this unit only. Do not use it with other equipment.

### User memo:

DATE OF PURCHASE \_\_\_\_\_  
DEALER NAME \_\_\_\_\_  
DEALER ADDRESS \_\_\_\_\_  
TELEPHONE NUMBER \_\_\_\_\_

The model number and serial number of this product can be found on either the back or the bottom of the unit. Please note them in the space provided below and keep for future reference.

MODEL NUMBER \_\_\_\_\_  
SERIAL NUMBER \_\_\_\_\_

## Table of contents

### Getting started

Accessories	2
IMPORTANT SAFETY INSTRUCTIONS	4
Maintenance	4
Disc information	5
Connection	6
Connection to a television	6
Home Theater—Enjoying more powerful sound	7
Control reference guide	8
The remote control	9
Quick Setup	9
Enjoying progressive video	9

### Basic operations

Basic play	10
When a menu screen appears on the television	10
Resume function	10
Using menus to play WMA/MP3 discs and CD text	11
Replaying a scene—QUICK REPLAY	12
Setting the unit to turn off—SLEEP timer	12
Starting play from a selected item	12
Skipping items	12
Fast forward and rewind—SEARCH	12
Slow-motion play	12
Frame-by-frame viewing	12

### Advanced operations

Playing the programs on DVD-RAM	13
Selecting a program to play—DIRECT NAVIGATOR	13
Using the play list menu	13
Convenient features	14
Improving CD sound—RE-MASTER	14
To enjoy even higher quality sound—AUDIO ONLY	14
Selecting groups to play	14
Selecting still pictures—Page Skip	14
A-B repeat play	14
Repeat play	15
Random play	15
Program play/All group play	15
Increasing your enjoyment of movies	16
Changing soundtracks, subtitles and angles	16
4:3 TV ZOOM function	16
ADVANCED SURROUND	17
BASS PLUS	17
CINEMA/CONCERT	17
DIALOGUE ENHANCER	17
ONE TOUCH CINEMA MEMORY	17
Using On-Screen Menu Icons	18
Common procedures	18
Disc information	18
Unit information	19
Progress indicator	20
Changing settings	21
Common procedures	22
Entering a password (Ratings)	22
Digital output	23
Speaker Setting	23

### Reference

Troubleshooting guide	24
Glossary	25
Limited Warranty (ONLY FOR U.S.A.)	26
Customer Services Directory (ONLY FOR U.S.A.)	26
Product Service	26
Guía de referencia rápida en español (Spanish Quick Reference)	27
Specifications	Back cover

## CAUTION!

THIS PRODUCT UTILIZES A LASER.  
USE OF CONTROLS OR ADJUSTMENTS OR  
PERFORMANCE OF PROCEDURES OTHER THAN  
THOSE SPECIFIED HEREIN MAY RESULT IN  
HAZARDOUS RADIATION EXPOSURE.  
DO NOT OPEN COVERS AND DO NOT REPAIR  
YOURSELF. REFER SERVICING TO QUALIFIED  
PERSONNEL.

## WARNING:

TO REDUCE THE RISK OF FIRE, ELECTRIC  
SHOCK OR PRODUCT DAMAGE, DO NOT  
EXPOSE THIS APPARATUS TO RAIN, MOISTURE,  
DRIPPING OR SPLASHING AND THAT NO  
OBJECTS FILLED WITH LIQUIDS, SUCH AS  
VASES, SHALL BE PLACED ON THE  
APPARATUS.

## CAUTION:

TO PREVENT ELECTRIC SHOCK MATCH WIDE  
BLADE OF PLUG TO WIDE SLOT, FULLY INSERT.

DANGER	- VISIBLE AND INVISIBLE LASER RADIATION WHEN OPEN. AVOID DIRECT EXPOSURE TO BEAM. (FDA 21 CFR)
CAUTION	- VISIBLE AND INVISIBLE LASER RADIATION WHEN OPEN. AVOID EXPOSURE TO BEAM. (IEC60825-1)
ATTENTION	- RAYONNEMENT LASER VISIBLE ET INVISIBLE EN CAS D'OUVERTURE. EXPOSITION DANGEREUSE AU FASCIAILL
ADVARSEL	- SYNLIG OG USYNLIG LASERSTRÅLING VED ÅBNING. UNDGÅ UDSÆTTELSE FOR STRÅLING.
VARO!	- AVATTAESSA OLET ALLITMA NÄKYVÄÄ JA NÄKYMÄTÖN LASERSÄTELYLLÄ, ÄLÄ KATSO SÄTEESEEN.
VARNING	- SYNLIG OCH OSYNLIG LASERSTRÅLING NÄR DENNA DEL ÄR ÖPPNAD. BETRÄKTA EJ STRÅLEN.
ADVARSEL	- SYNLIG OG USYNLIG LASERSTRÅLING NÄR DEKSEL ÅPNES. UNDGÅ EKSPONERING FOR STRÅLEN.
VORSICHT	- SICHTBARE UND UNSICHTBARE LASERSTRÄHLUNG WENN ABDECKUNG GEÖFFNET. NICHT DEM STRAHL AUSSETZEN.
注意	- 打开时有可见及不可见激光辐射。避免激光照射。
注意	- ここを開くと可能及び不可視のレーザー光が出ます。 ビームを直視したり、照れたりしないでください。 ROL90233

(Inside of product)

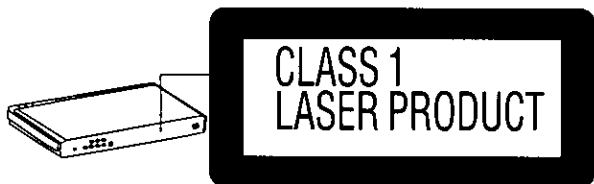

Do not place the unit  
on amplifiers or  
equipment that may  
become hot.

The heat can damage the unit.

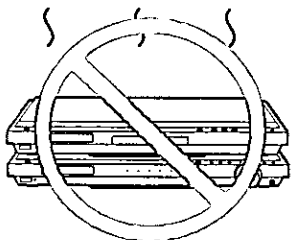

THE FOLLOWING APPLIES ONLY IN THE U.S.A.:

## CAUTION:

This equipment has been tested and found to comply with the limits for a Class B digital device, pursuant to Part 15 of the FCC Rules.

These limits are designed to provide reasonable protection against harmful interference in a residential installation. This equipment generates, uses and can radiate radio frequency energy and, if not installed and used in accordance with the instructions, may cause harmful interference to radio communications. However, there is no guarantee that interference will not occur in a particular installation. If this equipment does cause harmful interference to radio or television reception, which can be determined by turning the equipment off and on, the user is encouraged to try to correct the interference by one or more of the following measures:

- Reorient or relocate the receiving antenna.
- Increase the separation between the equipment and receiver.
- Connect the equipment into an outlet on a circuit different from that to which the receiver is connected.
- Consult the dealer or an experienced radio/TV technician for help.

Any unauthorized changes or modifications to this equipment would void the user's authority to operate this device.

This device complies with Part 15 of the FCC Rules.

Operation is subject to the following two conditions: (1) This device may not cause harmful interference, and (2) this device must accept any interference received, including interference that may cause undesired operation.



## CAUTION

RISK OF ELECTRIC SHOCK  
DO NOT OPEN



CAUTION: TO REDUCE THE RISK OF ELECTRIC  
SHOCK, DO NOT REMOVE SCREWS.  
NO USER-SERVICEABLE PARTS  
INSIDE.  
REFER SERVICING TO QUALIFIED  
SERVICE PERSONNEL.



The lightning flash with arrowhead symbol, within an equilateral triangle, is intended to alert the user to the presence of uninsulated "dangerous voltage" within the product's enclosure that may be of sufficient magnitude to constitute a risk of electric shock to persons.



The exclamation point within an equilateral triangle is intended to alert the user to the presence of important operating and maintenance (servicing) instructions in the literature accompanying the appliance.

# IMPORTANT SAFETY INSTRUCTIONS

Read these operating instructions carefully before using the unit. Follow the safety instructions on the unit and the applicable safety instructions listed below. Keep these operating instructions handy for future reference.

- 1) Read these instructions.
- 2) Keep these instructions.
- 3) Heed all warnings.
- 4) Follow all instructions.
- 5) Do not use this apparatus near water.
- 6) Clean only with dry cloth.
- 7) Do not block any ventilation openings. Install in accordance with the manufacturer's instructions.
- 8) Do not install near any heat sources such as radiators, heat registers, stoves, or other apparatus (including amplifiers) that produce heat.
- 9) Do not defeat the safety purpose of the polarized or grounding-type plug. A polarized plug has two blades with one wider than the other. A grounding-type plug has two blades and a third grounding prong. The wide blade or the third prong are provided for your safety. If the provided plug does not fit into your outlet, consult an electrician for replacement of the obsolete outlet.
- 10) Protect the power cord from being walked on or pinched particularly at plugs, convenience receptacles, and the point where they exit from the apparatus.
- 11) Only use attachments/accessories specified by the manufacturer.
- 12) Use only with the cart, stand, tripod, bracket, or table specified by the manufacturer, or sold with the apparatus. When a cart is used, use caution when moving the cart/apparatus combination to avoid injury from tip-over.
- 13) Unplug this apparatus during lightning storms or when unused for long periods of time.
- 14) Refer all servicing to qualified service personnel. Servicing is required when the apparatus has been damaged in any way, such as power-supply cord or plug is damaged, liquid has been spilled or objects have fallen into the apparatus, the apparatus has been exposed to rain or moisture, does not operate normally, or has been dropped.



## Maintenance

Clean this unit with the included cleaning cloth.

- Never use alcohol, paint thinner or benzine to clean this unit.

# Disc information

## Discs that can be played

Disc type	Logo	Indication in these operating instructions
<b>XP50</b> DVD-RAM		<b>RAM</b> Shown as "DVD-VR" on the display
<b>XP50</b> DVD-Audio		<b>DVD-A</b>
DVD-Video		<b>DVD-V</b>
DVD-R		
Video CD		<b>VCD</b>
CD		<b>CD</b> Including CD-R/RW
		<b>WMA</b> Discs recorded with WMA
		<b>MP3</b> Discs recorded with MP3

Do not use irregularly shaped discs (e.g. heart-shaped), as these can damage the unit.

## Discs that cannot be played

DVD-ROM, CD-ROM, CDV, CD-G, +RW, DVD-RW, CVD, SVCD, SACD, Divx Video Discs and Photo CD.

**XP50**: PAL discs (the audio on DVD-Audio can be played)

**XP30**: DVD-RAM, DVD-Audio and PAL discs

## DVDs that can be played

You can play discs with these symbols.



## Playing DVDs and Video CDs

The producer of these discs can control how they are played so you may not always be able to control play as described in these operating instructions. Read the disc's instructions carefully.

## CD-R and CD-RW discs

This unit can play CD-R and CD-RW if they are formatted as CD-DA (digital audio) or video CD and finalized\*.

## DVD-R discs

Panasonic DVD-R recorded and finalized\* on a Panasonic DVD video recorder are played as DVD-Video on this unit.

\*A process that allows play on compatible equipment.

## DVD-RAM discs **XP50**

DVD-RAM discs must meet the following conditions for this unit to be able to play them.

Type	<ul style="list-style-type: none"> <li>• Non-cartridge discs</li> <li>• Discs that can be removed from their cartridges (TYPE 2 and 4)</li> </ul>
Capacity	<ul style="list-style-type: none"> <li>• 12 cm (5") 9.4 GB (double-sided) and 4.7 GB (single-sided)</li> <li>• 8 cm (3") 2.8 GB (double-sided)</li> </ul>
Recording format	Discs recorded with DVD video recorders, DVD video cameras, personal computers, etc., using Version 1.1 of the Video Recording Format (a unified video recording standard).

- Remove TYPE 2 and 4 discs from their cartridges before use, then return them when you are finished. Read the instructions for the disc carefully.

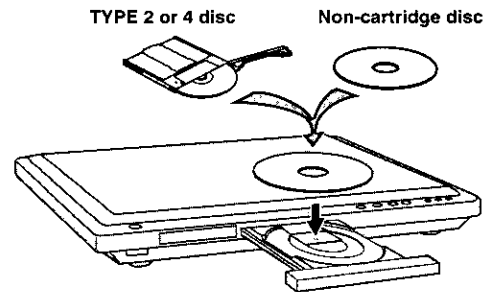

- Some parts of the disc, for example where one program ends and another begins, may not play smoothly.

## Note

It may not be possible to play CD-R, CD-RW, DVD-R and DVD-RAM in all cases due to the type of disc or condition of the recording.

## To clean discs

DVD-Audio, DVD-Video, Video CD, CD

Wipe with a damp cloth and then wipe dry.



## DVD-RAM, DVD-R

- Clean only with the DVD-RAM/PD disc cleaner available as an optional accessory (part number LF-K200DCA1).
- Never use cloths or cleaners for CDs etc.

## Handling precautions

- Do not write on the label side with a ball-point pen or other writing instrument.
- Do not use record cleaning sprays, benzene, thinner, static electricity prevention liquids or any other solvent.
- Do not attach labels or stickers to discs. (Do not use discs with exposed adhesive from tape or left over peeled-off stickers.)
- Do not use scratch-proof protectors or covers.
- Do not use discs printed with label printers available on the market.

## Connection to a television

This page explains how to connect the unit to a television and set it up so you hear the audio through the television's speakers. To get the full benefit from the powerful multi-channel audio found on DVDs, you should connect an amplifier and speakers (⇒ page 7).

**XP50** This model can decode Dolby Digital and DTS.

**XP30** This model can play Dolby Digital and DTS, but only in two channels.

### Before connection

- Disconnect the AC power supply cord.
- Refer to the television's operating instructions.

### Connect your unit directly to your television.

Do not connect the unit through your video cassette recorder when setting up your home entertainment system, because the picture may not be played correctly due to the copy guard.

### Conserving power

This unit consumes a small amount of power, even when it is turned off (approx. 2 W). To save power when the unit is not to be used for a long time, unplug it from the household AC outlet.

### Basic connection to a television

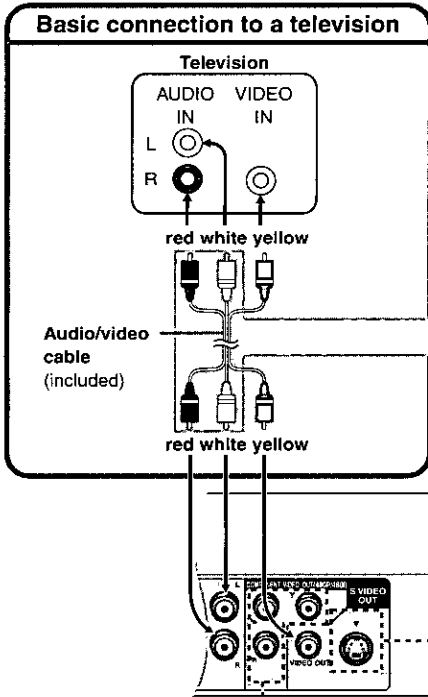

You can connect the audio cable to the 2-channel audio input terminals of an analog amplifier or system component to enjoy stereo or Dolby Pro Logic.

To household AC outlet (AC120 V, 60 Hz)

AC power supply cord (included)



### Enjoying higher picture quality

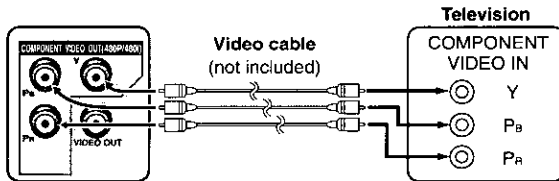

#### COMPONENT VIDEO OUT terminal

These terminals can be used for either interlace or progressive output and provide a purer picture than the S VIDEO OUT terminal. Connection using these terminals outputs the color difference signals (Pb/Pr) and luminance signal (Y) separately in order to achieve high fidelity in reproducing colors.

- The description of the component video input terminals depends on the television or monitor (e.g. Y/Pb/Pr, Y/B-Y/R-Y, Y/Cb/Cr). Connect to terminals of the same color.
- After making this connection, change the black level for a better picture. (⇒ page 21, Video—Black Level Control)

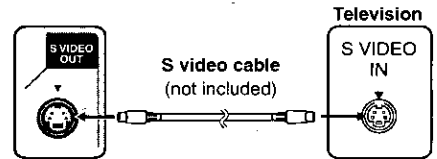

#### S VIDEO OUT terminal

The S video terminal achieves a more vivid picture than the VIDEO OUT terminal by separating the chrominance (C) and luminance (Y) signals. (Actual results depend on the television.)

When making this connection, ensure you connect the audio cables to the corresponding audio input terminals on the television.

### To enjoy progressive video

- Connect to the component video (480P) input terminals on a television compatible with this unit's copy guard system. (Video will not be displayed correctly if connected to an incompatible television.)
- In QUICK SETUP, set "Progressive Out" to "Enable" (⇒ page 9).

### For your reference

- All televisions manufactured by Panasonic and that have 480P input connectors are compatible. Consult the manufacturer if you have another brand of television.

## Home Theater—Enjoying more powerful sound

Enjoy the powerful movie theater and hall-like sound available with multiple channel audio found on DVDs by connecting an amplifier and speakers. There are two types of connection, digital and analog.

### A Digital (XP50 | XP30)

Connect an amplifier with Dolby Digital and DTS decoders to enjoy surround sound.

You can also enjoy high-quality stereo sound with sampling frequencies of 88.2 and 96 kHz if the material isn't copy-protected and the equipment you connect is compatible with these signals.

#### Note

- The equipment connections described are examples.
- Peripheral equipment and optional cables sold separately unless otherwise indicated.
- Before connection, turn off all equipment and read the appropriate operating instructions.

### B Analog (XP50)

Connect an amplifier with multi-channel audio input terminals to enjoy surround sound.

To obtain maximum performance of DVD-Audio multi-channel linear PCM sound, the connections **B** below are recommended. There are no limitations on sampling frequency with this kind of connection.

### A Digital connection XP50 | XP30

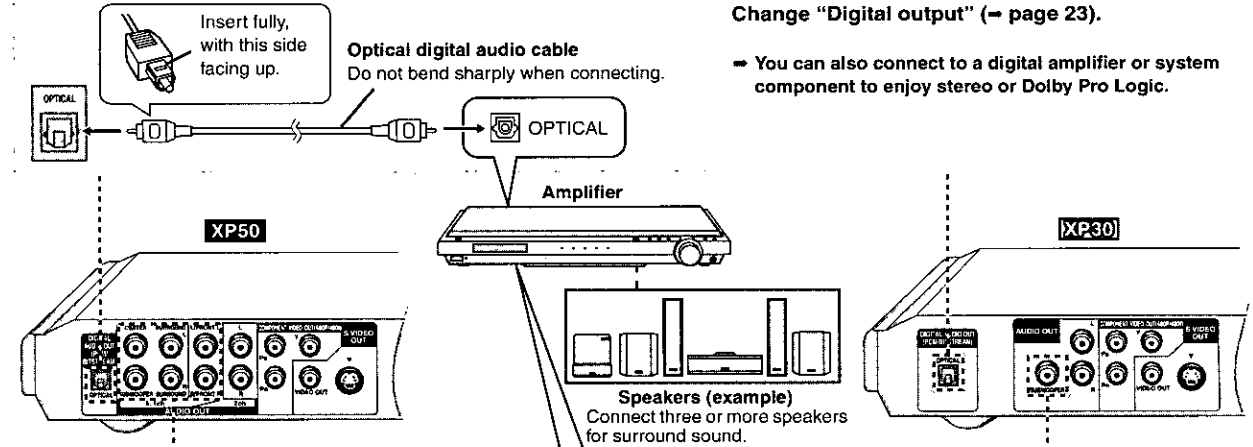

Change "Digital output" (→ page 23).

→ You can also connect to a digital amplifier or system component to enjoy stereo or Dolby Pro Logic.

### B Analog connection XP50

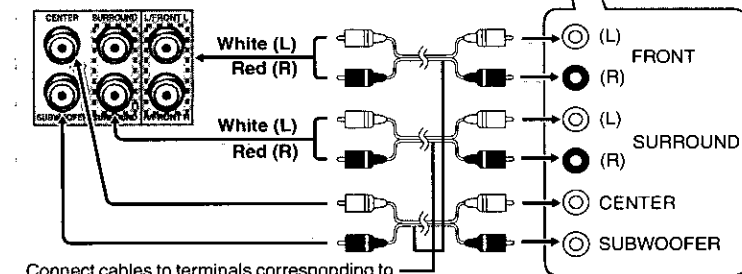

Change "Speaker Setting" (→ page 23).

#### Note

- You cannot use DTS Digital Surround decoders not suited to DVD-Video.

#### XP50

- If you don't connect a subwoofer, it is advisable to connect front speakers (L/R) capable of producing bass of less than 100 Hz.

#### Attenuator

If connected to a digital amplifier using connection **B** above, sound distortion may occur from the center, surround and subwoofer speakers. In this event, turn on the attenuator (→ page 19).

### Connecting an active subwoofer XP30

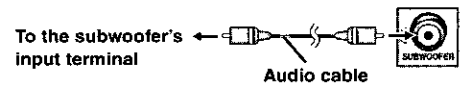

You can enjoy more powerful bass by connecting an active subwoofer.

- Place the subwoofer as close as possible to the front center.
- Turn BASS PLUS on to boost the output from the subwoofer (→ page 17).
- Adjust the volume on the subwoofer to suit your preference.

### Recording

- **Digital recording** (→ Connection **A** above)

You can record the digital signal directly to digital recording equipment.

#### Note

- With DVD, the following conditions must be met: ① the disc doesn't have protection preventing digital recording, and ② the recording equipment can handle signals with a sampling frequency of 48 kHz.
- You cannot record WMA/MP3.

When recording DVDs, make the following settings.

ADVANCED SURROUND: OFF (→ page 17)

Digital Audio Output: On (RE-MASTER Off) (→ page 21)

PCM Down Conversion: Yes

Dolby Digital/DTS Digital Surround: PCM (→ page 23)

- **Analog recording**

You can record to a cassette deck or other recording equipment. There are no limitations on recording analog signals as there are with digital signals. Connect the equipment to the unit's 2-channel AUDIO OUT (L/R) terminals.

**XP50** Select "2-channel" in "Speaker Setting" (→ page 21) when:

- using FRONT (L/R) AUDIO OUT terminals or,
- using connection **B** above.

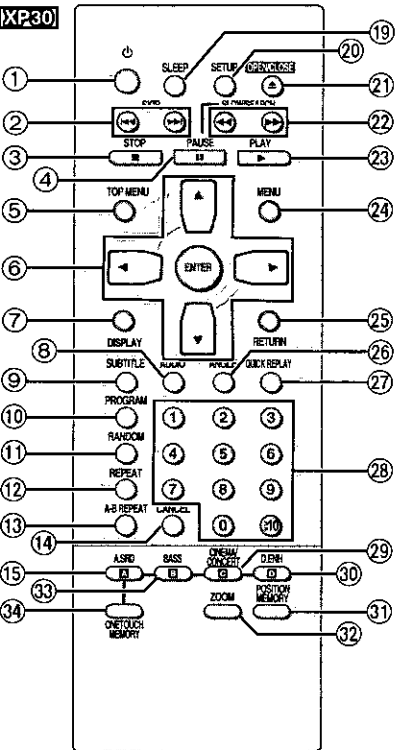
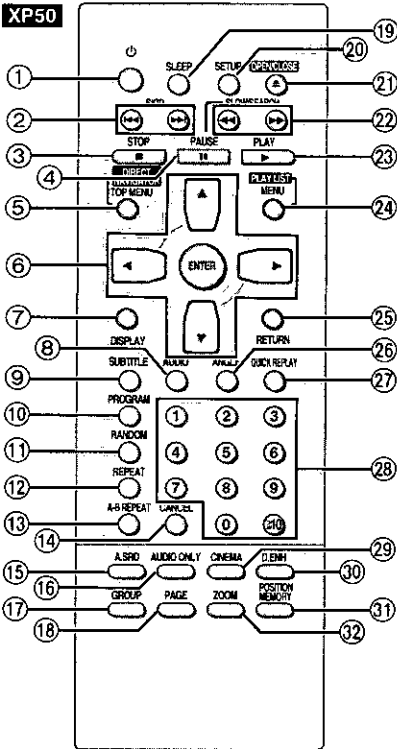

1	Standby/on button (⏻)	9
2	Skip buttons (⏮, ⏭) SKIP	12
3	Stop button (■ STOP)	10
4	Pause button (⏸ PAUSE)	10
5	XP50 Top menu, Direct navigator button (TOP MENU, DIRECT NAVIGATOR)	10, 13
6	XP30 Top menu button (TOP MENU)	10
7	Cursor buttons (▲, ▼, ◀, ▶), Enter button (ENTER)	9
8	Display button (DISPLAY)	18
9	Audio button (AUDIO)	16
10	Subtitle button (SUBTITLE)	16
11	Program button (PROGRAM)	15
12	Random button (RANDOM)	15
13	Repeat button (REPEAT)	15
14	A-B repeat button (A-B REPEAT)	14
15	Cancel button (CANCEL)	15
16	Advanced Surround button (A.SRD)	17
17	XP50 Audio only button (AUDIO ONLY)	14
18	XP50 Group button (GROUP)	14
19	XP50 Page button (PAGE)	14
20	Sleep button (SLEEP)	12
21	Setup button (SETUP)	9, 22
22	Open/Close button (▲ OPEN/CLOSE)	10
23	Slow/Search buttons (⏮, ⏭) SLOW/SEARCH	12
24	Play button (▶ PLAY)	10
25	XP50 Menu, Play list button (MENU, PLAY LIST)	10, 13
26	XP30 Menu button (MENU)	10
27	Return button (RETURN)	9
28	Angle button (ANGLE)	16
29	Quick replay button (QUICK REPLAY)	12
30	Numbered buttons (1-9, 0, ⏻)	10
31	XP50 Cinema button (CINEMA)	17
32	XP30 Cinema/Concert button (CINEMA/CONCERT)	17
33	Dialogue Enhancer button (D.ENH)	17
34	Position memory button (POSITION MEMORY)	10
35	4:3 TV zoom button (ZOOM)	16
36	XP30 Bass plus button (BASS)	17
37	XP30 One touch cinema memory button (ONE TOUCH MEMORY)	17
38	Display	
39	Disc tray	10
40	Skip/Slow/Search buttons (⏮, ⏭, ⏩, ⏪)	12
41	Re-master button (RE-MASTER)	14
42	Remote control signal sensor	

**XP50 XP30**

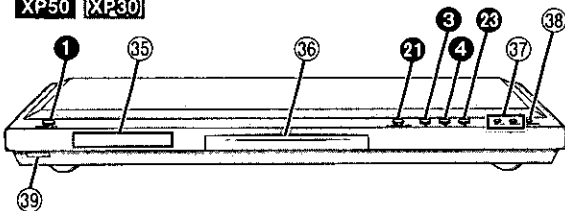

Buttons such as 1 function the same as the controls on the remote control.



# The remote control

## Batteries

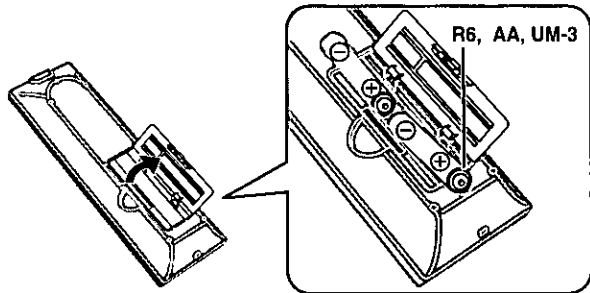

- Insert so the poles (+ and -) match those in the remote control.
- Do not use rechargeable type batteries.

## Do not:

- mix old and new batteries.
  - use different types at the same time.
  - heat or expose to flame.
  - take apart or short circuit.
  - attempt to recharge alkaline or manganese batteries.
  - use batteries if the covering has been peeled off.
- Mishandling of batteries can cause electrolyte leakage which can damage items the fluid contacts and may cause a fire.

Remove if the remote control is not going to be used for a long period of time. Store in a cool, dark place.

## Use

Aim at the sensor (⇒ page 8, Control reference guide), avoiding obstacles, at a maximum range of 7 m (23 feet) directly in front of the unit.

## Quick Setup

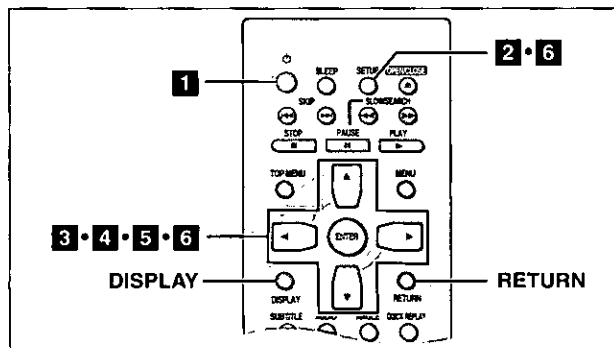

The **QUICK SETUP** screen appears when you press [SETUP] the first time after purchase and assists you to make necessary settings. You can access this screen again later if you need to (⇒ page 21, Others—QUICK SETUP).

### Preparation

Turn on the television and select the appropriate video input on the television to suit the connections for the player.

- 1 Press [POWER] to turn on the unit.
- 2 Press [SETUP] to show the **QUICK SETUP** screen.
- 3 Press [▲, ▼] to select the menu language and press [ENTER].
- 4 Press [▲, ▼] to select "Yes" to continue and press [ENTER].
- 5 Press [▲, ▼] to select the item and press [ENTER].
  - Audio Language (⇒ page 21)
  - Subtitle Language (⇒ page 21)
  - TV Aspect (⇒ right)
  - Progressive Out (⇒ page 21)
  - XP50 Speaker Setting (⇒ page 21)
- 6 Press [ENTER] and then [SETUP] to end the settings.

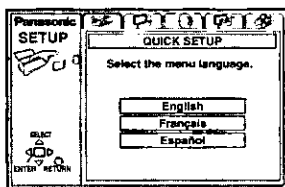

To return to the previous screen  
Press [RETURN].

## TV Aspect

Select "4:3" (regular) or "16:9" (widescreen) to suit your television. If you have a regular 4:3 television, you can also select how video on some discs is shown (⇒ page 21, Video—TV Aspect).

- **4:3 Pan&Scan** (Factory preset)  
Widescreen software is expanded to fill the screen of a 4:3 aspect television (unless prohibited by the producer of the disc).
- **4:3 Letterbox**  
Widescreen software is shown in the letterbox style on a 4:3 aspect television.



## Viewing 4:3 aspect pictures on a 16:9 widescreen television using progressive output

16:9 aspect pictures are shown correctly, but 4:3 aspect pictures are stretched horizontally to fill the screen.

- **If your television can change the aspect when input is progressive**  
Use the television to change the aspect to the correct one.
- **If your television cannot change the aspect when input is progressive**  
Switch Video output mode to "480I" (⇒ below) so the "PROG.OUT" indicator on the unit's display goes out. Output will now be interlace and 4:3 aspect picture is shown in the middle of the screen.

## Enjoying progressive video

### Preparation

- Connect through the COMPONENT VIDEO OUT terminals (⇒ page 6).
- In QUICK SETUP (or SETUP menus ⇒ page 21), set "Progressive Out" to "Enable".

1. Press [DISPLAY] to display Unit information.

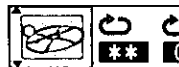

2. While the leftmost icon is highlighted, press [▲, ▼] to select Picture Menu.



3. Press [◀, ▶] to select Video output mode.
4. Press [▲, ▼] to select "480P" so the "PROG.OUT" indicator on the unit's display lights.

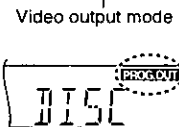

### Note

- Although the "PROG.OUT" indicator lights on the unit's display, output will still only be interlace if you have connected the unit to your television through the VIDEO OUT or S VIDEO OUT terminals.
- When progressive output is on, closed captions will not be displayed.



## Using menus to play WMA/MP3 discs and CD text

## WMA MP3

This unit can play WMA (Windows Media Audio) and MP3 files recorded on CD-R/RW with a computer. Files are treated as tracks and folders are treated as groups.

## CD (CD text)

This unit reads and displays the information on CD text discs. You can display disc titles, artist names and track titles.

## 1 Press [TOP MENU].

## 2 Press [▲, ▼] to select the track and press [ENTER].

Play continues to the last track in the last group.

"▶" indicates the track currently playing.

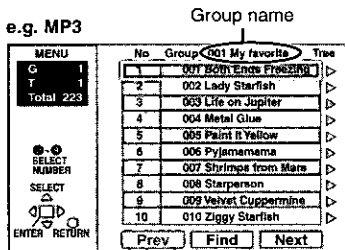

## To show other pages

Press [▲, ▼, ◀, ▶] to select "Prev" or "Next" and press [ENTER].

After listing all the tracks in one group, the list for the next group appears.

## To exit the file list

Press [TOP MENU].

## Note

- Discs must conform to ISO9660 level 1 or 2 (except for extended formats).
- This unit is compatible with multi-session but if there are a lot of sessions it takes more time for play to start. Keep the number of sessions to a minimum to avoid this.
- If you play an WMA/MP3 track that includes still picture data, it will take some time before the music itself starts playing and the elapsed time will not be displayed during this time. Even after the track starts, the correct play time will not be displayed.

## WMA

- When creating a WMA disc, ensure the copyright feature is off.
- WMA files must have the extension ".WMA" or ".wma".
- Noise may occur when playing WMA files.
- There are some files this unit cannot play (e.g., copyright protected). "TRACK PROTECTED" or "CANNOT PLAY THIS TRACK" appear on the unit's display to indicate such tracks.

## MP3

- MP3 files must have the extension ".MP3" or ".mp3".
- This unit is not compatible with ID3 tags.
- **XP50** This unit is not compatible with files with a sampling rate of 32 kHz.

## Naming folders and files

At the time of recording, prefix folder and file names with 3-digit numbers in the order you want to play them (this may not work at times).

## CD (CD text)

## When making your own CD text discs

The unit plays the tracks in the order you record them so you do not have to prefix the titles with numbers.

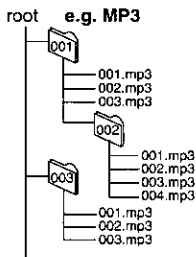

Windows Media, and the Windows logo are trademarks, or registered trademarks of Microsoft Corporation in the United States and/or other countries.

WMA is a compression format developed by Microsoft Corporation. It achieves the same sound quality as MP3 with a file size that is smaller than that of MP3.



## Using the tree screen to find a group WMA MP3

## 1 Press [▶] while a track is highlighted to display the tree screen.

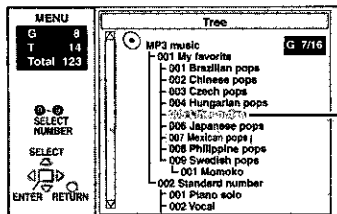

## 2 Press [▲, ▼] to select a group and press [ENTER].

The file list for the group appears.

## For your reference

Press [◀, ▶] to jump layers in the tree screen.

## To return to the file list

Press [RETURN].

## To show the text information for a track CD (CD text)

## 1 Press [▲, ▼] to select a track.

## 2 Press [▶] to show the text information.

- Press [◀, ▶] to select other tracks. Press [ENTER] to play tracks selected here.

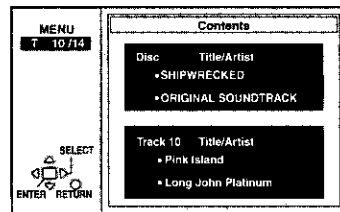

## To return to the list screen

Press [RETURN].

## Finding a track to play

Enter part of a track title to make a search. Although the characters are upper case, the unit also searches for lower case.

Example: search for tracks including the word "LOVE".

## 1 Press [▲, ▼] to select "Find" and press [ENTER].

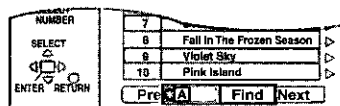

## 2 Press [▲, ▼] to select "L" and press [ENTER].

Characters change in alphanumeric order each time you press [▲].

- Press [◀, ▶] to skip between A, E, I, O and U.
- Press [◀] to erase a character.
- Repeat this step to enter "O", "V", and "E".

## 3 Press [▶] to select "Find" and press [ENTER].

The search results screen appears.

## 4 Press [▲, ▼] to select the track and press [ENTER].

Press [▼] to show other tracks if there are more than fifteen.

- To search for the first word in a title, erase the asterisk (\*) first.
- You can also enter numbers with the numbered buttons.

## To return to the list screen

Press [RETURN].

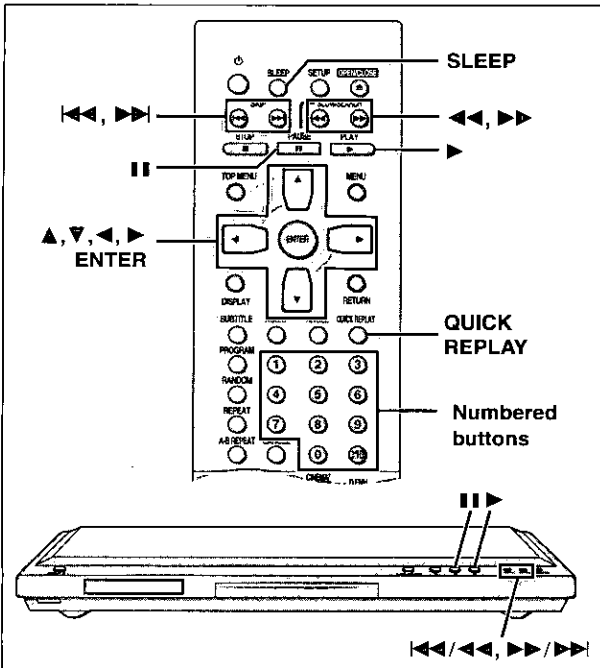

### Starting play from a selected item

RAM DVD-A DVD-V VCD CD WMA MP3

Press the numbered buttons to select the item.

To select a 2-digit number

e.g. 23: [ $\geq 10$ ] = [2] = [3]

WMA MP3

Press [ENTER] after pressing the numbered buttons. (You do not have to press [ $\geq 10$ ].)

Play starts from the selected item.

#### Note

- This works only when stopped with some discs.
- When playing DVD-Audio and you want to start play from a track in a different group, select the group first ( $\Rightarrow$  page 14).

### Skipping items

RAM DVD-A DVD-V VCD CD WMA MP3

You can skip chapters on DVD-Video, tracks on DVD-Audio, CDs and Video CDs, and on DVD-RAM you can skip to the start of a program, scene in a play list, or to a marker.

During play or while paused

Press [ $\lll$ ] or [ $\ggg$ ].

- Press [ $\lll/\lll$ ] or [ $\ggg/\ggg$ ] on the main unit.
- Each press increases the number of skips.

### Fast forward and rewind—SEARCH

RAM DVD-A DVD-V VCD CD WMA MP3

During play

Press [ $\lll$ ] or [ $\ggg$ ].

- Press and hold [ $\lll/\lll$ ] or [ $\ggg/\ggg$ ] on the main unit.
- You may erase sound during search ( $\Rightarrow$  page 21, Audio—Audio during Search).

### Slow-motion play

RAM DVD-A DVD-V VCD

While paused

Press [ $\lll$ ] or [ $\ggg$ ].

- Press and hold [ $\lll/\lll$ ] or [ $\ggg/\ggg$ ] on the main unit.

### Frame-by-frame viewing

RAM DVD-A DVD-V VCD

While paused

Press [ $\lll$ ] or [ $\ggg$ ].

The frame changes each time you press the button.

- The frames change in succession if you press and hold the button.
- Pressing [II] also activates forward frame-by-frame.

#### Notes

- The speed of search and slow-motion increases up to 5 steps.
- Press [▶] (PLAY) to restart play.
- You cannot move backwards with Video CD during slow-motion and frame-by-frame.
- Slow motion and frame-by-frame only work on the moving picture parts of DVD-Audio.
- **When playing Video CDs with playback control**  
Pressing buttons to perform skip, search or slow-motion may take you to a menu screen.

### Replaying a scene—QUICK REPLAY

RAM DVD-A DVD-V VCD CD WMA MP3

Skip back a few seconds within the current item (program, track or title).

During play

Press [QUICK REPLAY].

#### Note

This feature may not work while playing some parts of a disc or at all with some discs.

### Setting the unit to turn off—SLEEP timer

RAM DVD-A DVD-V VCD CD WMA MP3

Press [SLEEP] to select the setting.

Each time you press the button:

OFF  $\rightarrow$  AUTO\*  $\rightarrow$  60 min  $\rightarrow$  90 min  $\rightarrow$  120 min

$\uparrow$

\* The unit turns off 5 minutes after play finishes.



The unit turns off after 60 minutes.

To cancel the SLEEP timer

Press [SLEEP] to select "OFF".

To confirm the remaining time

Press [SLEEP].

#### Note

- AUTO also works with DVDs that show a menu after play finishes.
- AUTO does not work if you press [■], [MENU] or [TOP MENU]. It is activated again when you restart play.
- AUTO does not work correctly with some discs (e.g., if menus appear after playing Video CDs).

### Auto standby

The unit switches to standby mode after about 30 minutes in the stop mode, irrespective of the SLEEP setting.

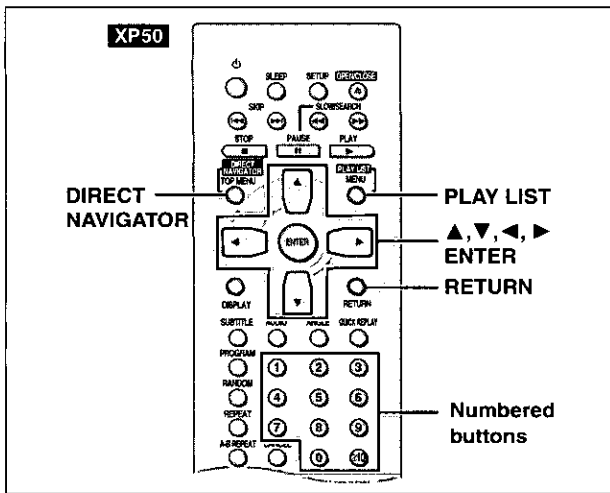

## Using the play list menu

You can play a group of scenes, a play list, created on other equipment such as a DVD video recorder. You can also specify scenes to play.

### Playing a play list

**1 Press [PLAY LIST].**

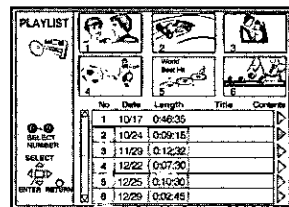

**2 Press [▲, ▼] to select the play list.**

- Press [▼] to show other play lists if there are more than six.
- You can select play lists with the numbered buttons.

**To select a 2-digit number**

e.g. 23: [≧10] ⇒ [2] ⇒ [3]

**3 Press [ENTER] to start play.**

### To clear the play list screen

Press [PLAY LIST].

(The unit returns to the condition it was in before you called up the play list.)

### To display information about a selected play list

1. Select the play list and press [▶].
2. Press [▲, ▼] to select "Contents" and press [ENTER]. Press [◀, ▶] to show other play lists.

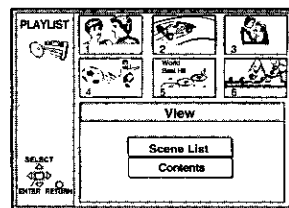

### To return to the previous screen

Press [RETURN].

## RAM

### Selecting a program to play—DIRECT NAVIGATOR

Use the program list to find programs to play.

**1 Press [DIRECT NAVIGATOR].**

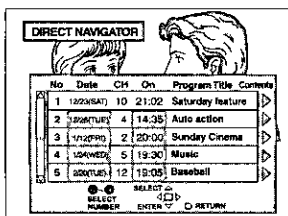

**2 Press [▲, ▼] to select the program.**

The selected program plays in the background.

- Press [▼] to show other programs if there are more than five.
- You can select programs with the numbered buttons.

**To select a 2-digit number**

e.g. 23: [≧10] ⇒ [2] ⇒ [3]

**3 Press [ENTER].**

The program being played in the background continues.

### To clear the program list

Press [DIRECT NAVIGATOR].

(The unit returns to the condition it was in before you called up the program list.)

### To display information about a selected program

Select the program and press [▶]. (The background picture pauses.) Press [◀, ▶] to show the other programs.

### To return to the previous screen

Press [RETURN].

## Note

- Titles appear only if you have entered them.
- You cannot change program and disc titles.

### Playing a specific scene

**1 Press [PLAY LIST].**

**2 Press [▲, ▼] to select the play list.**

- You can select play lists with the numbered buttons.

**To select a 2-digit number**

e.g. 23: [≧10] ⇒ [2] ⇒ [3]

**3 Press [▶].**

**4 Press [▲, ▼] to select "Scene List" and press [ENTER].**

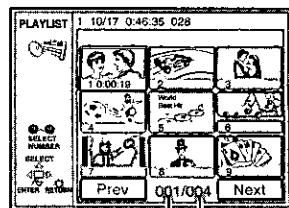

Page Total pages

**5 Press [▲, ▼, ◀, ▶] to select a scene and press [ENTER].**

- If there are more than 9 scenes, press [▲, ▼, ◀, ▶] to select "Next" and press [ENTER]. Select "Prev" to move back.

- You can also select a page with the numbered buttons.

**To select a number**

e.g. 23: [2] ⇒ [3] ⇒ [ENTER] (You do not have to press [≧10].)

### To return to the previous screen

Press [RETURN].

# Convenient features

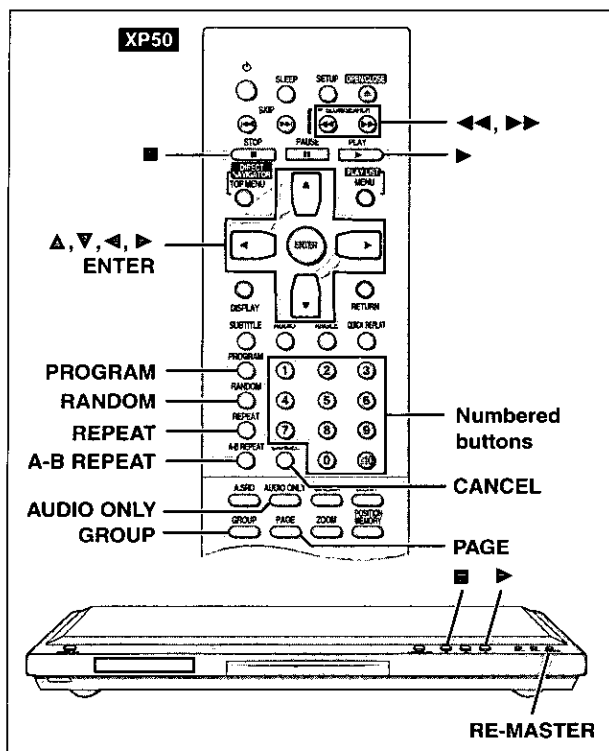

## Improving CD sound—RE-MASTER

[CD]

### Main unit only

Re-master digitally converts standard 44.1-kHz/16-bit CD signals to 88.2-kHz/24-bit so sound quality approaches that of DVD-Audio. There are 3 modes, each suited for a different music type.

### Press [RE-MASTER].

The indicator on the unit's display lights.

Each time you press the button:

- 1: Sharp acoustic imaging. Best suited for pop and rock.
  - 2: High clarity sound. Best suited for jazz.
  - 3: Smooth and full sound. Best suited for classical music.
- OFF: Original audio quality.

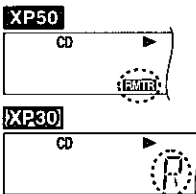

### Note

If you have connected equipment digitally, ensure your equipment can handle digital signals with sampling frequencies of 88.2 kHz and Digital Audio Output is set to "On (RE-MASTER On)" (⇒ page 21, Audio—Digital Audio Output). Some equipment cannot handle sampling frequencies of 88.2 kHz, even if they can handle 96 kHz. Read your equipment's operating instructions for details.

## To enjoy even higher quality sound—AUDIO ONLY

[XP50]

[RAM] [DVD-A] [DVD-V] [VCD] [CD] [WMA] [MP3]

You can enjoy higher quality audio by stopping the video signal.

During play

### Press [AUDIO ONLY].

The indicator on the unit's display lights.

- AUDIO ONLY is canceled if you press the button again or turn the unit off.

### Note

- Video is output when you stop the disc and during operations such as search.
- The television screen can appear unusual while video signals are not being output.

## Selecting groups to play

[XP50]

[DVD-A] [WMA] [MP3]

The tracks on DVD-Audio and WMA/MP3 are divided into groups. How these groups are played depends on the recording method.

e.g. MP3

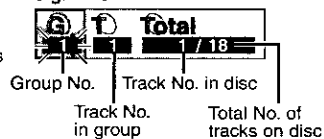

- 1 Press [GROUP].  
The group number changes each time you press the button.
- 2 Press [ENTER].
- 3 Press the numbered buttons to select the track number and press [ENTER].  
The selected group and track begin to play.

### Note

- You can also select groups and tracks with the cursor buttons.
- Selection may not be allowed in some situations.

[DVD-A] Playing all the groups in succession (⇒ page 15, All group play)

## Playing bonus groups

[DVD-A]

Some discs contain bonus groups. To enjoy these groups you may have to enter a password. Refer to the disc's jacket.

1. Select the bonus group while stopped (⇒ steps 1 and 2, above).
2. Enter the 4-digit password with the numbered buttons.
  - You can erase it by pressing [CANCEL].
3. Press [ENTER].
4. Press the numbered buttons to select a track and press [ENTER] to start play.

### Note

- Some discs will show a menu screen to accept your password. Follow the on-screen instructions.
- You may have to reenter the password after removing the disc or switching the unit to standby.

## Selecting still pictures—Page Skip

[XP50]

[DVD-A]

During play or while paused

### Press [PAGE].

The page changes each time you press the button.

[PAGE 1]

## A-B repeat play

[RAM] [DVD-A] [DVD-V] [VCD] [CD] [WMA] [MP3]

(When the elapsed play time is displayed)

You can repeat a section between points A and B within a program, title or track.

During play

- 1 Press [A-B REPEAT] at the starting point (A).
- 2 Press [A-B REPEAT] at the finishing point (B).

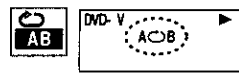

### To cancel

Press [A-B REPEAT] to display "\*\*".

### Note

- Some subtitles recorded around point A or B may fail to appear. [DVD-V]
- The unit automatically determines the end of a program/title/track as point B when the end of the program/title/track is reached.
- A-B repeat is canceled when you press [QUICK REPLAY].



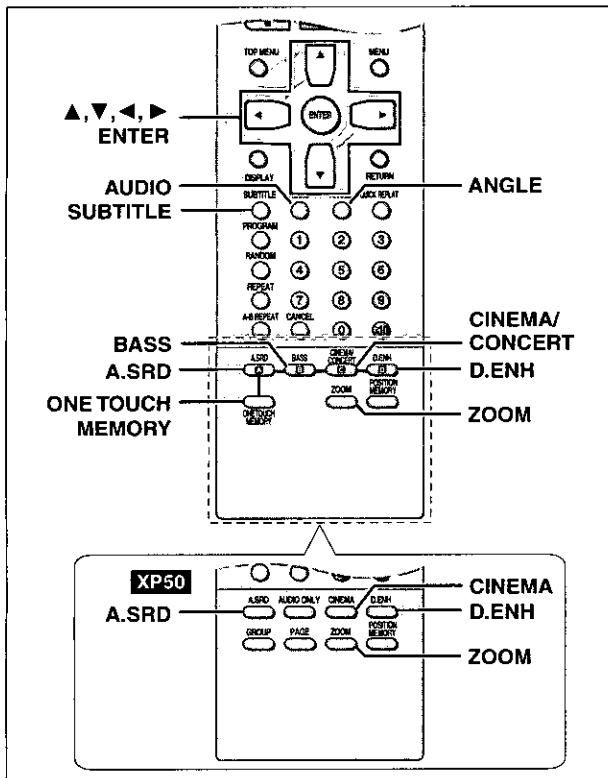

## Subtitles

**DVD-A DVD-V**: You can change the subtitle language and turn the subtitles on and off.

**RAM**: You can turn the subtitles on and off.

**During play**  
Press **[SUBTITLE]**.

The number changes each time you press the button.

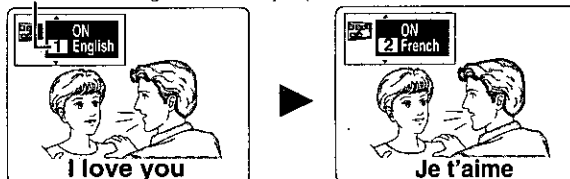

- In some cases, the subtitle language is not changed to the selected one immediately.
- If the subtitles overlap closed captions recorded on discs, turn the subtitles off.

**To clear/display the subtitles**

1. Press **[SUBTITLE]**.
2. Press **[▶]**. (**DVD-A DVD-V**)
3. Press **[▲, ▼]** to select "OFF" or "ON".

## Angles

**DVD-A DVD-V**

**During play**  
Press **[ANGLE]**.

The number changes each time you press the button.

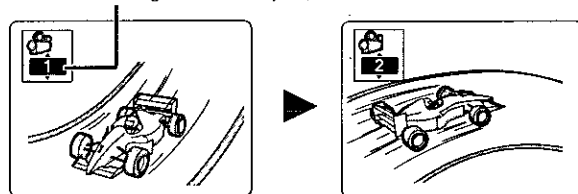

## Changing soundtracks, subtitles and angles

Some DVDs have multiple soundtracks, subtitle languages and camera angles, and you can change them during play.

- "—" or "—" is displayed instead of the language number in circumstances such as when no language is recorded on the disc.

### Soundtracks

**RAM DVD-A DVD-V VCD**

**During play**  
Press **[AUDIO]**.

**RAM VCD**

Each time you press the button:

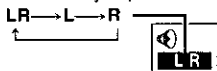

**DVD-A**

Soundtrack playing

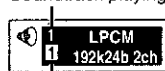

Soundtrack selected

**DVD-V**

The number changes each time you press the button.



- Indicates that a multi-channel soundtrack can be down-mixed to two channels.

e.g. DVD-Video

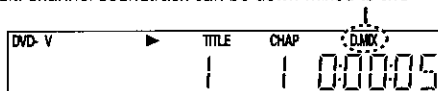

- You can also use this button to turn the vocals on and off on karaoke discs. Read the disc's instructions for details.
- Refer to **B** (page 19) for audio signal type details.

**XP50**

- Depending on the signal type of the recording on DVD-RAM, sometimes the audio settings will not be activated even if the display changes.
- Play restarts from the beginning of the soundtrack when playing DVD-Audio and DVD-RAM soundtracks that are accompanied by still pictures.
- Even if a second soundtrack isn't recorded on a DVD-Audio, two soundtrack numbers will normally be shown when you press **[AUDIO]**. The soundtrack currently playing is number 1.

## 4:3 TV ZOOM function

**RAM DVD-A DVD-V**

Widescreen software often appears as a letterbox picture (see page 9) when shown on a regular 4:3 aspect television. Use 4:3 TV ZOOM to expand these pictures to fill more of the television. (The sides of the picture are cut off when you do this.)

**During play**  
Press **[ZOOM]**.

Each time you press the button:

**ON** ↔ **OFF** (Factory preset)

- 4:3 TV ZOOM is canceled when the disc tray is opened or the unit is switched to standby.



### Note

- Depending on the video format of the disc and current play status, this feature may not work as described.
- Menus may act or appear differently while 4:3 TV ZOOM is on.



### ADVANCED SURROUND

RAM DVD-V VCD

SP: (Dolby Digital, DTS, LPCM, 2-channel or over only)

HP: (Dolby Digital, LPCM, 2-channel or over only)

Use ADVANCED SURROUND V.S.S. (Virtual Surround Sound) to enjoy a surround-like effect if you are using 2 front speakers (SP) or headphones (HP). (To enjoy HP-V.S.S., connect the unit to equipment that has a headphone jack.)

If you are playing a disc with surround effects recorded on it, the effect is broadened and sound seems to come from virtual speakers on either side.

#### Press [A.SRD].

Each time you press the button:

- SP1/HP1: Natural effect
- ↓
- SP2/HP2: Emphasized effect
- ↓
- SP OFF/HP OFF: Cancel (Factory preset)

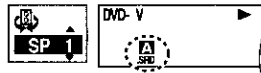

#### To change the mode:

[◀] = [▲, ▼] to select "SP" or "HP"

#### Optimum seating position

<When using the television's speakers>

Distance A = Television's width

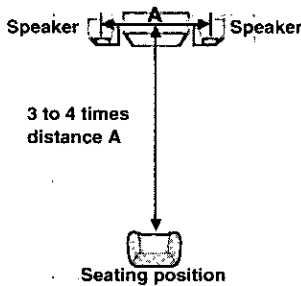

#### Note

- ADVANCED SURROUND will not work, or will have less effect with some discs.
- Turn off the surround sound effects on the equipment you have connected when using this effect.
- Turn ADVANCED SURROUND off if it causes distortion.
- Even if three or more speakers are connected, output from this unit will be in stereo (two channels) when ADVANCED SURROUND is on.
- Turn ADVANCED SURROUND off when using Dolby Pro Logic. Dolby Pro Logic will not work correctly if it is on.

### BASS PLUS

XP30

DVD-V VCD CD WMA MP3

Turn BASS PLUS on when you have connected an active subwoofer to the SUBWOOFER terminal on the rear of the unit (= page 7).

#### Press [BASS].

Each time you press the button:

- 2: Emphasized bass effect
- ↓
- OFF
- ↓
- 1: Natural bass effect (Factory preset)

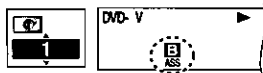

#### Note

- Turn BASS PLUS off when using Dolby Pro Logic. Dolby Pro Logic will not work correctly if it is on.

### CINEMA/CONCERT

You can change the quality of the picture and audio to suit the material you are playing.

#### XP50 Press [CINEMA].

RAM DVD-A DVD-V VCD

Each time you press the button:

- Cinema 1: Mellows images and enhances detail in dark scenes.
- ↓
- Cinema 2: Sharpens images and enhances detail in dark scenes.
- ↓
- Normal: Normal mode (Factory preset)



#### XP30 Press [CINEMA/CONCERT].

Each time you press the button:

- Cinema: DVD-V VCD Mellows images and enhances detail in dark scenes.
- ↓
- Concert: DVD-V VCD CD WMA MP3 Enhance detail in dark scenes, suppress brightness and add power to sound when watching live performances.
- ↓
- Normal: Normal mode (Factory preset)



#### For your reference

- You can make finer adjustments to the picture if desired (= page 20, Picture Menu).
- XP30 Turn on the attenuator if sound output from the speakers (two channels) is distorted while "Concert" is on (= page 19, Audio Menu).

### DIALOGUE ENHANCER

DVD-V

(Dolby Digital, DTS, 3-channel or over, where the dialogue is recorded in the center channel)

This makes the dialogue in movies easier to hear.

#### Press [D.ENH].

Each time you press the button:  
ON ← → OFF (Factory preset)

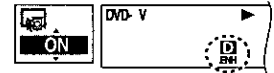

#### Note

DIALOGUE ENHANCER will not work or will have less effect with some discs.

### ONE TOUCH CINEMA MEMORY

XP30

This feature allows you to reselect the settings you made for ADVANCED SURROUND, BASS PLUS, CINEMA/CONCERT and DIALOGUE ENHANCER with one button press.

#### Putting the settings into memory

After making the settings

#### Press and hold [ONE TOUCH MEMORY].

"M" lights.  
The settings remain in the memory even if you turn the unit off.

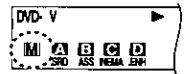

#### Recalling the settings

#### Press [ONE TOUCH MEMORY].

"M" lights.

#### To cancel

Press [ONE TOUCH MEMORY] to turn it off and return the settings for the features to the factory preset.

- ADVANCED SURROUND: SP OFF/HP OFF
- BASS PLUS: 1
- CINEMA/CONCERT: Normal
- DIALOGUE ENHANCER: OFF

"M" goes out if you press any of the other buttons to change the settings.

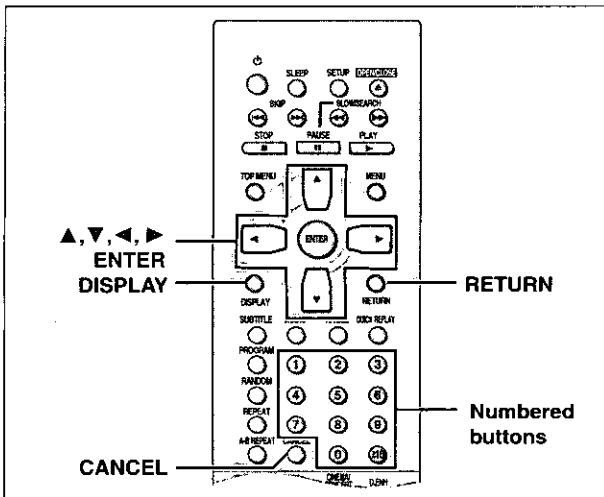

RAM DVD-A DVD-V VCD CD WMA MP3

On-Screen Menu Icons are menus that contain information about the disc or unit. These menus allow you to perform operations by changing this information.

## Common procedures

### 1 Press [DISPLAY].

Each time you press the button:

Disc information (→ right) → Progress indicator (→ page 20)

Original display ← Unit information (→ pages 19, 20)

### 2 [Unit information only]

While the leftmost icon is highlighted  
Press [▲, ▼] to select the menu.

Each time you press the button:

Play Menu ↔ Picture Menu

Display Menu ↔ Audio Menu

### 3 Press [◀, ▶] to select the item.

### 4 Press [▲, ▼] to select the setting.

- Items with "▲" or "▼" above and below can be changed by [▲, ▼].
- Press [ENTER] if the setting does not change after pressing [▲, ▼].
- Some items require different operations. Read the following explanations.

#### For your reference

- Depending on the condition of the unit (playing, stopped, etc.) and the type of software, there are some items that you cannot select or change.
- When numbers are displayed (e.g. title No.), the numbered buttons are also effective for setting. Press [ENTER] to register the setting.

#### To clear the menus

Press [RETURN] until the menus disappear.

#### To change the position of the icons

1. Press [◀, ▶] to select the Bar Position icon.
2. Press [▲, ▼] to move the icons. (There are 5 positions.)



## Disc information

e.g. DVD-Video

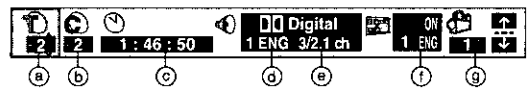

e.g. WMA/MP3 disc

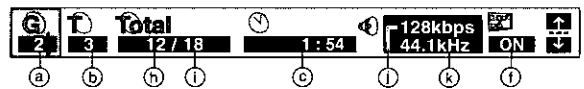

e.g. Video CD

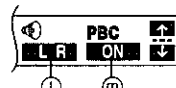

e.g. DVD-Audio

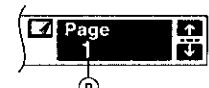

a PG: Program number RAM

PL: Play list number RAM

T: Title number DVD-V

Track number VCD CD

G: Group number DVD-A WMA MP3

b T: Track number in group DVD-A WMA MP3

C: Chapter number DVD-V

c Time RAM DVD-A DVD-V

- Press [▲, ▼] to show the elapsed play time or remaining time for the program, group, track or title (or chapter during program and random play).

- Select a position to start play by specifying a time with the numbered buttons and press [ENTER].

Changing the time display VCD CD

Press [▲, ▼] to show the elapsed play time, remaining time for the track, or remaining time for the disc.

Elapsed play time WMA MP3

(display only, cannot be changed)

d Soundtrack language DVD-A DVD-V (→ page 16)

(See A on page 19 for language abbreviations.)

e Audio signal type RAM DVD-A DVD-V (→ page 16)

(See B on page 19 for details.)

Karaoke vocal on/off (Karaoke DVD only) DVD-V

Solo: OFF or ON

Duet: OFF, V1 + V2, V1 or V2

i Subtitle language DVD-A DVD-V (→ page 16)

(See A on page 19 for language abbreviations.)

Subtitles on/off RAM DVD-A DVD-V

ON ↔ OFF

Track information on/off WMA MP3 CD (CD text)

ON ↔ OFF

g Angle number DVD-A DVD-V (→ page 16)

h Track number in disc WMA MP3

i Total number of tracks on disc WMA MP3

j Current bitrate WMA MP3

k Current sampling frequency WMA MP3

l Audio mode RAM VCD (→ page 16)

LR ↔ L ↔ R

m Menu play VCD (with playback control only)

Indicates whether menu play (playback control) is on or off.

n Still picture number DVD-A

Selected picture is shown during play.

**Unit information**

**Play Menu**

e.g. DVD-Video

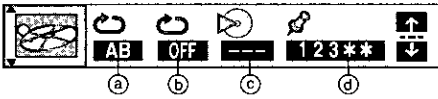

a) **A-B repeat** [RAM] [DVD-A] [DVD-V] [VCD] [CD] [WMA] [MP3] (⇒ page 14)  
[ENTER] (start point) ⇒ [ENTER] (finish point)  
To cancel: [ENTER]

b) **Repeat mode** (⇒ page 15)

[RAM]	[DVD-A]	[WMA]	[MP3]	[DVD-V]	[VCD]	[CD]
PG: Program	T: Track	C: Chapter	T: Title	A: All	A: All* <sup>1</sup>	A: All* <sup>2</sup>
A: All	G: Group	A: All* <sup>2</sup>	OFF: Off	OFF: Off	OFF: Off	OFF: Off

\*<sup>1</sup>During play list play. "PL" is not displayed while playing a specific play list scene.

\*<sup>2</sup>During all group, program and random play

c) **Play mode display** [DVD-A] [DVD-V] [VCD] [CD] [WMA] [MP3]

---: Normal play  
PGM: Program play  
RND: Random play  
ALL: All group play [DVD-A]

d) **Marker**

[DVD-A] [DVD-V] [VCD] [CD] [WMA] [MP3]: 5 positions  
[RAM]: 999 positions

[ENTER] (The unit is now ready to accept markers.)

To mark a position: [ENTER] (at the desired point)

To mark another position: [◀, ▶] ⇒ [ENTER]

To recall a marker: [◀, ▶] ⇒ [ENTER]

To erase a marker: [◀, ▶] ⇒ [CANCEL]

[RAM]

To mark the eleventh point and beyond

1. [◀, ▶] to select the marker pin icon

2. [▲, ▼] to select "11-20"

You can select the next group when the current group is full.

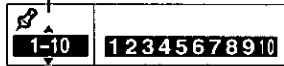

- This feature doesn't work while using a play list.
- The markers are ordered by time. This means that the marker numbers can change when you add and erase markers.
- Markers placed using a recording device (e.g. DVD video recorder) will be displayed. While these may be erased temporarily, they will be redisplayed if the disc tray is opened or the unit is switched to standby.

**Note**

- This feature doesn't work during program and random play.
- All the markers are cleared when the disc tray is opened or the unit is switched to standby.

**Audio Menu**

e.g. DVD-Video

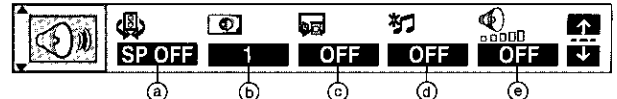

a) **ADVANCED SURROUND** [RAM] [DVD-V] [VCD] (⇒ page 17)

- VSS mode SP ↔ HP
- SP/HP level 1 ↔ 2 ↔ OFF

b) **XP30 BASS PLUS** [DVD-V] [VCD] [CD] [WMA] [MP3] (⇒ page 17)

1 ↔ 2 ↔ OFF

c) **DIALOGUE ENHANCER** [DVD-V] (⇒ page 17)

ON ↔ OFF

d) **RE-MASTER** [CD] (⇒ page 14)

1 ↔ 2 ↔ 3 ↔ OFF

e) **Attenuator** [RAM] [DVD-A] [DVD-V] [VCD] [CD] [WMA] [MP3]

(XP50 ⇒ page 7, Note—Attenuator)

(XP30 ⇒ page 17, CINEMA/CONCERT—For your reference)

ON ↔ OFF

**Display Menu**

e.g. DVD-Video

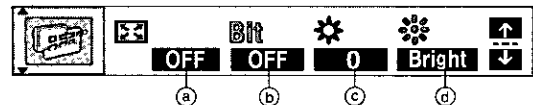

a) **4:3 TV ZOOM** [RAM] [DVD-A] [DVD-V] (⇒ page 16)

ON ↔ OFF

b) **Bitrate display** [RAM] [DVD-A] [DVD-V] [VCD]

Displays the bitrate (approximate values) and type of picture (⇒ page 25, Glossary—I/P/B)

ON ↔ OFF

To change the bitrate display: [◀, ▶]

9.438 Mbps ▶

- During play: shows the average bitrate of the video being played
- While paused: shows the data volume of the frame

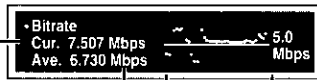

- A record of bitrates for a sampling period.

c) **OSD brightness** (−3 to +3)

Adjust the brightness of the on-screen displays.

d) **FL dimmer** [RAM] [DVD-A] [DVD-V] [VCD] [CD] [WMA] [MP3]

Changes the brightness of the unit's display.

Bright ↔ Dim ↔ Auto\* ([RAM] [DVD-A] [DVD-V] [VCD])

\* The display is dimmed during play, but brightens when you perform operations such as slow-motion, search, and pause.

**A Audio/Subtitle language**

ENG: English	POR: Portuguese
FRA: French	RUS: Russian
DEU: German	JPN: Japanese
ITA: Italian	CHI: Chinese
ESP: Spanish	KOR: Korean
NLD: Dutch	MAL: Malay
SVE: Swedish	VIE: Vietnamese
NOR: Norwegian	THA: Thai
DAN: Danish	*: Others

**B Signal type/data**

LPCM/PPCM/□□ Digital/DTS/MPEG: Signal type

k (kHz): Sampling frequency

b (bit): Number of bits

ch (channel): Number of channels

Example: 3/2\_1ch

- 1: Subwoofer signal (not displayed if there is no subwoofer signal)
- 0: No surround
- 1: Mono surround
- 2: Stereo surround (left/right)
- 1: Center
- 2: Front left+Front right
- 3: Front left+Front right+Center

## Unit information

## Picture Menu

RAM DVD-A DVD-V VCD

## When the progressive out indicator on the unit's display is on



a b c d

## User mode



e f g h



a b c d

## When the progressive out indicator on the unit's display is off



a b

## User mode



e f g h

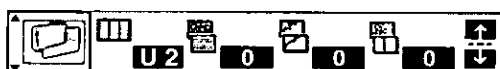

a b c d



a b

## a Picture mode (⇒ page 17, CINEMA/CONCERT)

## XP50

- N: Normal mode
- C1: Mellow images and enhances detail in dark scenes
- C2: Sharpens images and enhances detail in dark scenes
- U1/U2/U3\*: User mode (⇒ right)

## XP30

- N: Normal mode
- C (Cinema): Mellow images and enhances detail in dark scenes
- C (Concert): Enhance detail in dark scenes, suppress brightness and add power to sound when watching live performances
- U1/U2/U3\*: User mode (⇒ right)
- U3 appears only when the progressive out indicator on the unit's display is off.

## b Video output mode

(⇒ page 25, Glossary—Interlace and progressive output)  
480I: (Interlace video) ↔ 480P: (Progressive video)

You can change the video output mode only when "Progressive Out" in the Video menu is set to "Enable" (⇒ page 21).

## c Transfer mode

Select the method of conversion for progressive output to suit the type of material being played (⇒ page 25, Glossary—Film and video).

- Auto 1 (normal): for viewing film material
- Auto 2: for viewing film material (the same as Auto 1, but able to convert 30-frame-per-second progressive video)
- Video: for video material

## d Horizontal position (−20 to +20)

Change the picture's position if it is off center.

1. Press [ENTER].
2. Press [◀, ▶] to move the picture.
3. Press [ENTER] to enter the position (saved even if you turn the unit off).

## User mode

## To change the user mode

1. Select User mode and press [▶] to highlight the number.
2. Press [▲, ▼] to select "1", "2" or "3".



## — MPEG Digital Noise Reduction —

## e 3D-NR (0 to +4)

Reduces overall noise.

## f Block NR (0 to +3)

Smooths block noise.

## g Mosquito NR (0 to +3)

Reduces the smudging that appears around contrasting sections of the picture.

## — Picture Control —

## h Contrast (−7 to +7)

Increases the contrast between light and dark parts of the picture.

## i Brightness (0 to +15)

Brightens the picture.

## j Color (−7 to +7)

Adjust the shade of the picture's color.

## Progress Indicator

Indicates how far you have played through an item.



## a Current position RAM DVD-A DVD-V VCD CD WMA MP3

## b PG: Program number RAM

PL: Play list number RAM

T: Title number DVD-V

Track number VCD CD

G: Group number DVD-A WMA MP3

## c T: Track number in group DVD-A WMA MP3

C: Chapter number DVD-V

## d Condition – play, pause, or slow/search

RAM DVD-A DVD-V VCD CD WMA MP3

## e Changing the time display RAM DVD-A DVD-V VCD CD





Press [▲, ▼] to show the elapsed play time or remaining time for the program, track or title (or chapter during program and random play).

Elapsed play time WMA MP3

(display only, cannot be changed)

# Changing settings

This chart shows the settings for this unit. Change the settings to suit your preferences and to suit the unit to the environment in which it is being used. These settings are retained in memory until they are changed, even if the unit is turned off. See page 22 for details on menu operation.

Menus	Items	Options (Underlined items are the factory preset.)
	<b>Audio</b> Choose the audio language.	<u>English</u> French    Spanish Original*1    Other *****2
	<b>Subtitle</b> Choose the subtitle language.	<u>Automatic</u> *3    English    French    Spanish Other *****2
	<b>Menus</b> Choose the language for disc menus.	<u>English</u> French    Spanish Other *****2
	<b>Ratings</b> Set a ratings level to limit DVD-Video play. •The password screen is shown if you choose levels 0 to 7 or if you choose "Ratings" when levels 0 to 7 have been selected (⇒ page 22). •Select "Level 0" to prevent play of discs that do not have ratings levels recorded on them.	<b>Setting ratings (When level 8 is selected)</b> <u>8 No Limit</u> 1 to 7**4    0 Lock All <hr/> <b>Changing ratings (When level 0-7 is selected)</b> Unlock Player    Change Password Change Level    Temporary Unlock
	<b>TV Aspect (⇒ page 9)</b> Choose the setting to suit your television and preference.	<u>4:3 Pan&amp;Scan</u> 4:3 Letterbox    16:9
	<b>Progressive Out</b> Choose "Enable" to enable progressive output.	<u>Disable</u> Enable
	<b>Still Mode (⇒ page 25, Glossary—Frame still and field still)</b> Specify the type of picture shown when paused.	<u>Automatic</u> Field    Frame
	<b>Black Level Control</b> Change the black level of the picture if you connected a television through the COMPONENT VIDEO OUT terminals.	<b>Lighter:</b> when connected to a TV through the VIDEO OUT or S VIDEO OUT terminal. <b>Darker:</b> when connected to a TV through the COMPONENT VIDEO OUT (Y/Pa/Pr) terminals.
	<b>Speaker Setting XP50 (⇒ page 23)</b> Choose the settings to suit your audio system and the listening environment.	<b>Multi-channel:</b> when 3 or more speakers are connected. •Speaker presence and size •Delay time    •Channel balance <hr/> <b>2-channel:</b> when 2 speakers or an amplifier with a Dolby Pro Logic decoder is connected.
	<b>Digital Audio Output (⇒ page 23, Digital output)</b> Select whether to output digital signals or not, and whether digital signals are affected by the re-master settings. •On (RE-MASTER Off): Digital signals are output. The re-master settings (⇒ page 14) do not affect this output. •On (RE-MASTER On): Digital signals are output. The re-master settings (⇒ page 14) are effective. The equipment you connected will be unable to output audio when the re-master circuit is functioning if it cannot handle digital signals with sampling frequencies of 88.2 kHz. •Off: Digital signals are not output. This improves sound quality when you are using analog connection.	<u>On (RE-MASTER Off)</u> On (RE-MASTER On) Off
	<b>PCM Down Conversion (⇒ page 23)</b>	<u>No</u> Yes
	<b>Dolby Digital (⇒ page 23)</b>	<u>Bitstream</u> PCM
	<b>DTS Digital Surround (⇒ page 23)</b>	<u>PCM</u> Bitstream
	<b>Dynamic Range Compression (Dolby Digital only) (⇒ page 25, Glossary)</b> Change the dynamic range for late night viewing.	<u>Off</u> On
	<b>Audio during Search*5</b> Choose whether to have sound during search.	<u>On</u> Off
	<b>Menu Language</b> Choose the language for these menus and the on-screen messages.	<u>English</u> Français    Español
	<b>On-Screen Messages</b> Choose whether to show on-screen messages or not.	<u>On</u> Off
	<b>DVD-Video Mode XP50</b> Select how to play pictures contained on some DVD-Audio. The setting returns to "Off" when you remove the disc or turn the unit off.	<u>Off:</u> DVD-Audio are played as DVD-Audio. On: DVD-Video contents found on DVD-Audio can be played.
	<b>Demo</b> A demonstration of the unit's on-screen displays starts when you select "On". The demonstration stops when you press a button and the setting reverts to "Off".	<u>Off</u> On
	<b>QUICK SETUP (⇒ page 9)</b> Answer questions to make basic settings.	Yes <u>No</u>

\*1 The original language of each disc will be selected.

\*2 Input a code number with the numbered buttons (⇒ page 22).

\*3 If the language selected for "Audio" is not available, subtitles of that language will automatically appear if available on that disc.

\*\*4 Prohibits play of DVD-Video with corresponding ratings recorded on them.

\*5 This feature doesn't work for WMA files and DTS-CD discs. Audio will be heard when playing some DVD-Audio despite the settings you make here.

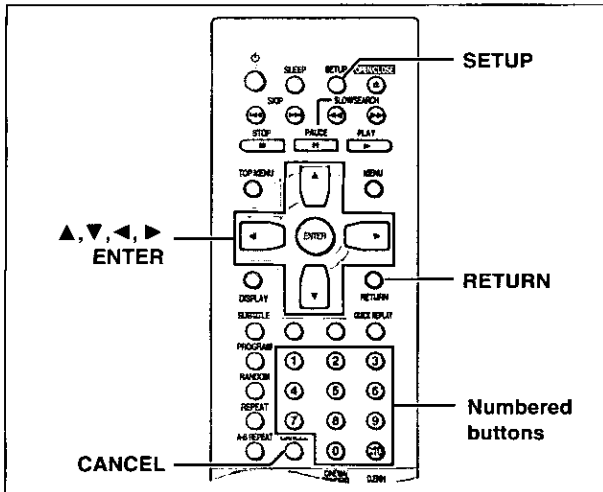

- 3 Press [**▲**, **▼**] to select the item you want to change and press [**ENTER**].
- 4 Press [**▲**, **▼**] to select the option and press [**ENTER**].  
The screen now shows the menu again.

To return to the previous screen  
Press [**RETURN**].  
To exit the **SETUP** menu  
Press [**SETUP**].

## Entering a password (Ratings)

- DVD-V**
- The password screen is shown when you select levels 0 to 7.
1. Input a 4-digit password with the numbered buttons.
    - If you enter a wrong number, press [**CANCEL**] to erase it.
  2. Press [**ENTER**].
    - The lock symbol appears closed to show the rating is locked.
    - **Do not forget your password.**
  3. Press [**ENTER**] to confirm the 4 digits.

Now, when you insert a DVD-Video that exceeds the ratings limit you set, a message appears on the television.  
Follow the on-screen instructions.

Advanced operations

## Common procedures

See page 21 for menu and option details.

- 1 Press [**SETUP**] to show the menus.

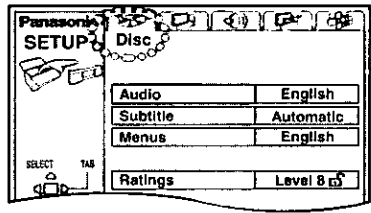

• The **QUICK SETUP** screen appears when you press [**SETUP**] the first time after purchase (= page 9).

- 2 Press [**◀**, **▶**] to select the menu's tab.

The screen changes to display the menu.

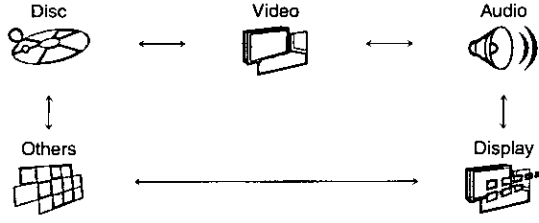

## Language code list

Abkhazian: 6566	Byelorussian: 6669	Georgian: 7585	Kashmiri: 7583	Mongolian: 7778	Serbo-Croatian: 8372	Tigrinya: 8473
Afar: 6565	Cambodian: 7577	German: 6869	Kazakh: 7575	Nauru: 7865	Shona: 8378	Tonga: 8479
Afrikaans: 6570	Catalan: 6765	Greek: 6976	Kirghiz: 7589	Nepali: 7869	Sindhi: 8368	Turkish: 8482
Albanian: 8381	Chinese: 9072	Greenlandic: 7576	Korean: 7579	Norwegian: 7879	Singhalese: 8373	Turkmen: 8475
Ameharic: 6577	Corsican: 6779	Guarani: 7178	Kurdish: 7585	Oriya: 7982	Slovak: 8375	Twi: 8487
Arabic: 6582	Croatian: 7282	Gujarati: 7185	Laotian: 7679	Pashto, Pushto: 8083	Slovenian: 8376	Ukrainian: 8575
Armenian: 7289	Czech: 6783	Hausa: 7265	Latin: 7665	Persian: 7065	Somali: 8379	Urdu: 8582
Assamese: 6583	Danish: 6865	Hebrew: 7387	Latvian, Lettish: 7686	Polish: 8076	Spanish: 6983	Uzbek: 8590
Aymara: 6588	Dutch: 7876	Hindi: 7273	Lingala: 7678	Portuguese: 8084	Sundanese: 8385	Vietnamese: 8673
Azerbaijani: 6590	English: 6978	Hungarian: 7285	Lithuanian: 7684	Punjabi: 8065	Swahili: 8387	Volapük: 8679
Bashkir: 6665	Esperanto: 6979	Icelandic: 7383	Macedonian: 7775	Quechua: 8185	Swedish: 8386	Welsh: 6789
Basque: 6985	Estonian: 6984	Indonesian: 7378	Malagasy: 7771	Rhaeto-Romance: 8277	Tagalog: 8476	Wolof: 8779
Bengali, Bangla: 6678	Faroese: 7079	Interlingua: 7365	Malay: 7783	Romanian: 8279	Tajik: 8471	Xhosa: 8872
Bhutani: 6890	Fiji: 7074	Irish: 7165	Malayalam: 7776	Russian: 8285	Tamil: 8465	Yiddish: 7473
Bihari: 6672	Finnish: 7073	Italian: 7384	Maltese: 7784	Samoan: 8377	Tatar: 8484	Yoruba: 8979
Breton: 6682	French: 7082	Japanese: 7465	Maori: 7773	Sanskrit: 8365	Telugu: 8469	Zulu: 9085
Bulgarian: 6671	Frisian: 7089	Javanese: 7487	Marathi: 7782	Scots Gaelic: 7168	Thai: 8472	
Burmese: 7789	Galician: 7176	Kannada: 7578	Moldavian: 7779	Serbian: 8382	Tibetan: 6679	

## Digital output

DVD-A DVD-V

Change the settings when you have connected equipment through this unit's DIGITAL AUDIO OUT terminal (OPTICAL).

## PCM Down Conversion

Select how to output audio with a sampling frequency of 96 kHz or 88.2 kHz.

- Select "Yes" if the equipment you connect cannot process signals with a sampling frequency of 96 kHz or 88.2 kHz.
- Also make the appropriate "Digital Audio Output" setting (⇒ page 21).

**No** (Factory preset): Output as 96 kHz or 88.2 kHz

**Yes**: Converted to 48 kHz or 44.1 kHz

### Note

- Signals are converted to either 48 kHz or 44.1 kHz despite the above settings if the signals have a sampling frequency of over 96 kHz, or the disc has copy protection.
- Some equipment cannot handle sampling frequencies of 88.2 kHz, even if they can handle 96 kHz. Read your equipment's operating instructions for details.

## Dolby Digital and DTS Digital Surround

**Bitstream** (Factory preset for Dolby Digital):

Select if the equipment you connected can decode the signal.

**PCM** (Factory preset for DTS Digital Surround):

Select if the equipment you connected cannot decode the signal.

### IMPORTANT

If the equipment you connected cannot decode the signal, the setting must be changed to PCM. If not, signals the equipment cannot process will be output by this unit, causing high levels of noise which can damage your hearing and the speakers.

## Speaker Setting

### XP50

Change speaker presence and size (a), delay time (b), and channel balance (c) to suit the speakers you have connected.

These settings are not necessary when you select "2-channel" (only two speakers are connected).

### Note

This feature works only for analog connection (⇒ page 7).

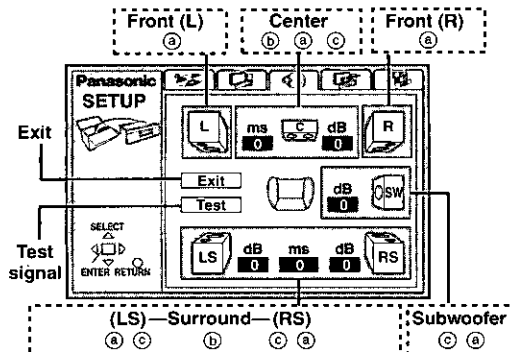

## Speaker presence and size (a)

1. Press [**▲**, **▼**, **◀**, **▶**] to select the item and press [ENTER].
2. Press [**▲**, **▼**] to select the setting and press [ENTER].

Icon examples:

Surround speaker (LS)



No



Large



Small

- **Large**: When the speaker supports low-frequency (under 100 Hz) reproduction.
- **Small**: Select when the speaker does not support low-frequency reproduction.

If the subwoofer is set to "No", the front speakers will automatically be set to "Large".

## Delay time (b)

**DVD-V** (Dolby Digital, center and surround speakers only)

For optimum listening with 5.1-channel sound, all the speakers, except for the subwoofer, should be the same distance from the seating position. If you have to place the center or surround speakers closer to the seating position, adjust the delay time to make up for the difference.

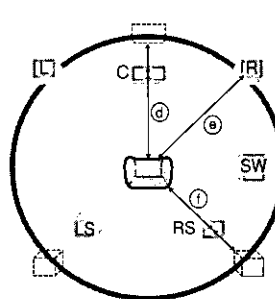

### Center speaker

Difference	Setting
Approx. 50 cm (1 1/2 feet)	1.3 ms
Approx. 100 cm (3 feet)	2.6 ms
Approx. 150 cm (5 feet)	3.9 ms
Approx. 200 cm (6 feet)	5.3 ms

### Surround speakers

Difference	Setting
Approx. 200 cm (6 feet)	5.3 ms
Approx. 400 cm (12 feet)	10.6 ms
Approx. 600 cm (18 feet)	15.9 ms

If distances (a) (from the center speaker) and (b) (from the surround speakers) are the same as or greater than (c) (from the front speakers), leave the delay time as "0", the factory preset.

If either distance (a) or (b) is less than (c), find the difference in the relevant table and change to the recommended setting.

### Changing the delay time

1. Press [**▲**, **▼**, **◀**, **▶**] to select the delay time box and press [ENTER].
2. Press [**▲**, **▼**] to adjust the delay time and press [ENTER].

## Channel balance (c)

1. Press [**▲**, **▼**, **◀**, **▶**] to select "Test" and press [ENTER]. A test signal is output from one speaker at a time, starting with the front left speaker and proceeding clockwise.

Front (L) → Center → Front (R)

↑ Surround (LS) ← Surround (RS) ↓

2. While listening to the test signal, press [**▲**, **▼**] to adjust the volume of the center and surround speakers so they are the same apparent volume as the front speakers (-6 to +6). (The front speakers cannot be adjusted here.)
3. Press [ENTER].

The test signal stops.

- No signal is output for the subwoofer. To adjust its volume, play something, then return to this screen to adjust to suit your taste.

### To finish the speaker setting

Press [**▲**, **▼**, **◀**, **▶**] to select "Exit" and press [ENTER].

### Note

The unit may be unable to output as set here due to limitations imposed by the unit itself or the disc being played. (The display's "D.MIX" indicator goes out in these cases.)

# Troubleshooting guide

Before requesting service, make the below checks. If you are in doubt about some of the check points, or if the remedies indicated in the chart do not solve the problem:

*In the U.S.A., contact the Panasonic Customer Call Center at 1-800-211-7262, or e-mail [consumerproducts@panasonic.com](mailto:consumerproducts@panasonic.com), or web site (<http://www.panasonic.com>).*

*In Canada, contact Panasonic Canada Inc. Customer Care Centre at 1-800-561-5505, web site ([www.panasonic.ca](http://www.panasonic.ca)), or an authorized Servicentre closest to you.*

## Power

		Page
No power.	● Insert the AC power supply cord securely into the household AC outlet.	6
The unit is automatically switched to the standby mode.	● To conserve power, the unit automatically switches to standby after approximately 30 minutes in the stop mode. Turn the power back to ON.	-
	● The unit was switched to standby by the SLEEP timer.	12

## Operation

No response when buttons pressed.	● Some operations may be prohibited by the disc.	-
	● The unit may not be operating properly due to lightning, static electricity or some other external factor. <b>Reset procedure:</b> Press [⏻] to switch the unit to the standby mode and then back to ON. Alternatively, press [⏻] to switch the unit to the standby mode, disconnect the AC power supply cord, and then reconnect it.	-
No operations can be performed with the remote control.	● Check that the batteries are installed correctly.	9
	● The batteries are depleted: Replace them with new ones.	9
	● Point the remote control at the remote control sensor and operate.	9
Play doesn't start (or stops immediately) when you press [▶] (PLAY).	● Condensation has formed: Wait 1 to 2 hours for it to evaporate.	-
	● This unit cannot play discs other than the ones listed in these operating instructions.	5
	● This unit cannot play DVD-Video with a region number other than "1", "ALL" or multiple region numbers including "1".	Cover page 5
	● The disc may be dirty and may require cleaning.	10
	● Ensure that the disc is installed with the label of the side to be played facing upwards. ● Check that the DVD-RAM has something recorded on it. <b>XP50</b>	-
Cannot select alternative languages.	● This function is dependent on software availability. ● Try selecting from the disc's menu if one is available.	10
No menu play.	● This function is dependent on software availability.	-
No subtitles.	● This function is dependent on software availability. ● Subtitles are cleared from the television. Display the subtitles.	16
Soundtrack and/or subtitle language is not the one selected with the SETUP menus.	● This function is dependent on software availability.	-
Cannot change angle.	● This function is dependent on software availability. Even if a disc has a number of angles recorded, these angles may be recorded for specific scenes only.	-
DIALOGUE ENHANCER has no effect.	● This feature does not work when the unit is outputting bitstream signals.	-
You have forgotten your ratings password. Reset all the settings to Factory Preset.	● While stopped, press and hold [◀◀] and [▶▶] on the unit and then also press and hold [▲] on the unit until "Initialized" disappears from the television. Turn the unit off and on again. All settings will return to the default values.	-
The progressive out indicator does not light.	● Go to Video in the SETUP menus, and select "Enable" in "Progressive Out".	21

## Picture

Picture distorted.	● Some distortion is normal during SEARCH. <b>XP50</b>	-
	● The screen may be disrupted briefly when you turn off the AUDIO ONLY feature.	-
	● If "This disc is PAL system. The output is sound only." is on the television, then you have loaded a PAL system DVD-Audio and only the audio portion of the disc can be played.	-
No picture.	● Check the connection. ● Make sure the television is on. ● Ensure the television's video input setting (e.g., VIDEO 1) is correct.	6
The picture shown on the television is not normal. (The sides of the picture are cut off, the picture is stretched horizontally, or black bands appear at the top and bottom of the screen.)	● Go to Video in the SETUP menus, and change "TV Aspect" to suit your television.	9, 21
	● Use the television to change the aspect to the correct one. <b>If your television cannot change the aspect when input is progressive</b> Switch Video output mode to "480i" so the "PROG.OUT" indicator on the unit's display goes out. Output will now be interlace.	9
	● The 4:3 TV ZOOM function is on.	16
	● Ensure that the unit is connected directly to the television, and is not connected through a video cassette recorder.	6
	● Connect to the component video (480P) input terminals on a television compatible with this unit's copy guard system. You cannot view progressive video if your television is not compatible.	6
There is ghosting when progressive output is on.	● This problem is caused by the editing method or material used on DVD-Video, but should be corrected if you use interlace output. Switch Video output mode to "480i" so the "PROG.OUT" indicator on the unit's display goes out. Output will now be interlace.	9
Picture quality is poor.	● Check the settings in the On-Screen Menu Icons' Picture Menu.	20
The picture is off center when progressive output is on.	● Adjust the horizontal position in the On-Screen Menu Icons' Picture Menu.	20



Sound		Page
No sound. Distorted sound.	• Check the connections.	6, 7
	• Check the volume on the equipment you have connected.	-
	• Ensure that the input settings on the other equipment are correct.	-
	• Turn <b>ADVANCED SURROUND</b> off if it causes distortion.	17
	• <b>XP50</b>	17
	• Output from this unit will be in stereo (two channels) when <b>ADVANCED SURROUND</b> is on. Turn <b>ADVANCED SURROUND</b> off if you are using three or more speakers.	23
Piercing noise comes from the speakers.	• If you have connected this unit to an amplifier through the <b>AUDIO OUT</b> terminals, go to the Audio menu in the <b>SETUP</b> menu, and change "Speaker Setting" to suit to your speakers. Select the large or small icon for all the speakers you have connected.	-
	• Due to the specifications on some types of televisions, both video and audio may be cut off when you turn the <b>AUDIO ONLY</b> feature on.	-
	• If the "D.MIX" indicator on the display goes out while playing a multi-channel DVD-Audio disc, sound will only be output from speakers specified by the disc. Read the disc's instructions for details.	-
	• If you have connected this unit to other equipment through the <b>DIGITAL AUDIO OUT</b> terminal, ensure you have selected the correct settings for "Dolby Digital" and "DTS Digital Surround" in the <b>SETUP</b> menus' Audio menu.	23

### Unit displays

"NO PLAY"	• You inserted a disc the unit cannot play; insert one it can. • You inserted a blank DVD-RAM. <b>XP50</b>	5 -
"CHECK DISC"	• Disc is dirty: Wipe it clean.	5
"H□□" □□ stands for a number.	• Trouble may have occurred. The number following "H" depends on the status of the unit. <b>Reset procedure:</b> Press [⏻] to switch the unit to the standby mode and then back to ON. Alternatively, press [⏻] to switch the unit to the standby mode, disconnect the AC power supply cord, and then reconnect it. • If the service numbers fail to clear, note the service number and contact a qualified service person.	- -
"NO DISC"	• You haven't inserted a disc: Insert one. • You haven't inserted the disc correctly: Insert it correctly.	- 10

### Television displays

"The progressive out is set to "Disable""	• Go to Video in the <b>SETUP</b> menus, and select "Enable" in "Progressive Out".	21
"The software has a 4:3 aspect ratio"	• Use the television to change the aspect to the correct one. <b>If your television cannot change the aspect when input is progressive</b> Switch Video output mode to "480i" so the "PROG.OUT" indicator on the unit's display goes out. Output will now be interlace.	- 9
No on-screen display.	• Go to Display in the <b>SETUP</b> menus, and select "On" for "On-Screen Messages".	21
On-screen displays (including On-Screen Menu Icons) not displayed or only partially displayed on the television.	• Press [DISPLAY], and press [◀, ▶] to highlight the Bar Position icon, then press [▲, ▼] to adjust the position.	18
The disc's menu is displayed in a different language.	• Go to Disc in the <b>SETUP</b> menus, and select the preferred language for "Menus".	21

## Glossary

### Bitstream

This is the digital form of multiple channel audio data (e.g., 5.1 channel) before it is decoded into its various channels.

### Decoder

A decoder restores the coded audio signals on DVDs to normal. This is called decoding.

### Dolby Digital

This is a method of coding digital signals developed by Dolby Laboratories. Apart from stereo (2-channel) audio, these signals can also be multi-channel audio. A large amount of audio information can be recorded on one disc using this method.

### Dolby Pro Logic

A surround system where a 4-channel audio track is recorded as 2 channels and then is restored to 4 channels for play. The surround channel is monaural and can reproduce up to 7 kHz.

### DTS (Digital Theater Systems)

This surround system is used in many movie theaters around the world. There is good separation between the channels, so realistic sound effects are possible.

### Dynamic range

Dynamic range is the difference between the lowest level of sound that can be heard above the noise of the equipment and the highest level of sound before distortion occurs.

### Film and video

DVD-Videos are recorded using either film or video. Usually, film is recorded at 24 frames per second, the rate movies are filmed at, while video is recorded at 30 frames per second.

### Frame still and field still

Frames are the still pictures that go together to make a moving picture. There are about 30 frames shown each second.

One frame is made up of two fields. A regular television shows these fields one after the other to create frames.

A still is shown when you pause a moving picture. A frame still is made up of two alternating fields, so the picture may appear blurred, but overall quality is high. A field still is not blurred, but it has only half the information of a frame still so picture quality is lower.

### Interlace and progressive output

NTSC, the video signal standard, has 480 interlaced (i) scan lines, whereas progressive scanning uses twice the number of scan lines. This is called 480P. The video signals output from this unit's **COMPONENT VIDEO OUT** terminals (Y, Pb, Pr) allow you to enjoy higher quality pictures than if the signals were output from the **VIDEO OUT** terminal or **S VIDEO OUT** terminal.

### I/P/B

MPEG 2, the video compression standard adopted for use with DVD-Video, codes frames using these 3 picture types.

### I: Intra coded picture

This picture has the best quality and is the best to use when adjusting the picture.

### P: Predictive coded picture

This picture is calculated based on past I or P-pictures.

### B: Bidirectionally-predictive coded picture

This picture is calculated by comparing past and future I and P-pictures so it has the lowest volume of information.

### Linear PCM (pulse code modulation)

These are uncompressed digital signals, similar to those found on CDs.

### Playback control (PBC)

If a Video CD has playback control, you can select scenes and information with menus (called menu play in these instructions).

## Limited Warranty (ONLY FOR U.S.A.)

Panasonic Consumer Electronics Company,  
Division of Matsushita Electric Corporation of America  
One Panasonic Way Secaucus, New Jersey 07094

Panasonic Sales Company, Division of Matsushita Electric  
of Puerto Rico, Inc.  
Ave. 65 de Infantería, Km. 9.5  
San Gabriel Industrial Park, Carolina, Puerto Rico 00985

## Panasonic DVD Player/Recorder Limited Warranty

### Limited Warranty Coverage

If your product does not work properly because of a defect in materials or workmanship, Panasonic Consumer Electronics Company or Panasonic Sales Company (collectively referred to as "the warrantor") will, for the length of the period indicated on the chart below, which starts with the date of original purchase ("warranty period"), at its option either (a) repair your product with new or refurbished parts, or (b) replace it with a new or a refurbished product. The decision to repair or replace will be made by the warrantor.

Product or Part Name	Parts	Labor
DVD Player	One (1) Year	Ninety (90) Days
DVD Recorder	One (1) Year	One (1) Year
Rechargeable Batteries, DVD-RAM Disc (in exchange for defective item)	Ten (10) Days	Not Applicable

During the "Labor" warranty period there will be no charge for labor. During the "Parts" warranty period, there will be no charge for parts. You must carry-in or mail-in your product during the warranty period. If non-rechargeable batteries are included, they are not warranted. This warranty only applies to products purchased and serviced in the United States or Puerto Rico. This warranty is extended only to the original purchaser of a new product which was not sold "as is". A purchase receipt or other proof of the original purchase date is required for warranty service.

### Carry-In or Mail-In Service

For Carry-In or Mail-In Service in the United States call 1-800-211-PANA(7262) or visit Panasonic Web Site: <http://www.panasonic.com>

For assistance in Puerto Rico call Panasonic Sales Company (787)-750-4300 or fax (787)-768-2910.

### Limited Warranty Limits And Exclusions

This warranty ONLY COVERS failures due to defects in materials or workmanship, and DOES NOT COVER normal wear and tear or cosmetic damage. The warranty ALSO DOES NOT COVER damages which occurred in shipment, or failures which are caused by products not supplied by the warrantor, or failures which result from accidents, misuse, abuse, neglect, mishandling, misapplication, alteration, faulty installation, set-up adjustments, misadjustment of consumer controls, improper maintenance, power line surge, lightning damage, modification, or commercial use (such as in a hotel, office, restaurant, or other business), rental use of the product, service by anyone other than a Factory Servicenter or other Authorized Servicer, or damage that is attributable to acts of God.

**THERE ARE NO EXPRESS WARRANTIES EXCEPT AS LISTED UNDER "LIMITED WARRANTY COVERAGE". THE WARRANTOR IS NOT LIABLE FOR INCIDENTAL OR CONSEQUENTIAL DAMAGES RESULTING FROM THE USE OF THIS PRODUCT, OR ARISING OUT OF ANY BREACH OF THIS WARRANTY.** (As examples, this excludes damages for lost time, travel to and from the servicer, loss of media or images, data or other recorded content. The items listed are not exclusive, but are for illustration only.) **ALL EXPRESS AND IMPLIED WARRANTIES, INCLUDING THE WARRANTY OF MERCHANTABILITY, ARE LIMITED TO THE PERIOD OF THE LIMITED WARRANTY.**

Some states do not allow the exclusion or limitation of incidental or consequential damages, or limitations on how long an implied warranty lasts, so the exclusions may not apply to you.

This warranty gives you specific legal rights and you may also have other rights which vary from state to state. If a problem with this product develops during or after the warranty period, you may contact your dealer or Servicenter. If the problem is not handled to your satisfaction, then write to the warrantor's Consumer Affairs Department at the addresses listed for the warrantor.

**PARTS AND SERVICE WHICH ARE NOT COVERED BY THIS LIMITED WARRANTY ARE YOUR RESPONSIBILITY.**

## Customer Services Directory (ONLY FOR U.S.A.)

*For Product Information, Operating Assistance, Literature Request, Dealer Locations, and all Customer Service inquiries please contact:*

*1-800-211-PANA (7262), Monday-Friday 9 am-9 pm; Saturday-Sunday 9 am-7 pm, EST.*

*Web Site: <http://www.panasonic.com>  
You can purchase parts, accessories or locate your nearest servicenter by visiting our Web Site.*

### Accessory Purchases:

1-800-332-5368 (Customer Orders Only)  
Panasonic Services Company 20421 84th Avenue South, Kent, WA 98032  
(6 am to 5 pm Monday-Friday; 6 am to 10:30 am Saturday; PST)  
(Visa, MasterCard, Discover Card, American Express, Check)

### Service in Puerto Rico

*Matsushita Electric of Puerto Rico, Inc. Panasonic Sales Company/Factory Servicenter:  
Ave. 65 de Infantería, Km. 9.5, San Gabriel Industrial Park, Carolina, Puerto Rico 00985  
Phone (787) 750-4300 Fax (787) 768-2910*

## Product Service

- 1. Damage requiring service**—The unit should be serviced by qualified service personnel if:
  - (a) The AC power supply cord or AC adaptor has been damaged; or
  - (b) Objects or liquids have gotten into the unit; or
  - (c) The unit has been exposed to rain; or
  - (d) The unit does not operate normally or exhibits a marked change in performance; or
  - (e) The unit has been dropped or the cabinet damaged.
- 2. Servicing**—Do not attempt to service the unit beyond that described in these operating instructions. Refer all other servicing to authorized servicing personnel.
- 3. Replacement parts**—When parts need replacing ensure the servicer uses parts specified by the manufacturer or parts that have the same characteristics as the original parts. Unauthorized substitutes may result in fire, electric shock, or other hazards.
- 4. Safety check**—After repairs or service, ask the servicer to perform safety checks to confirm that the unit is in proper working condition.

### Product Information

For product information or assistance with product operation:

In the U.S.A., contact the Panasonic Customer Call Center at 1-800-211-7262, or e-mail [consumerproducts@panasonic.com](mailto:consumerproducts@panasonic.com), or web site (<http://www.panasonic.com>).

In Canada, contact Panasonic Canada Inc. Customer Care Centre at 1-800-561-5505, web site ([www.panasonic.ca](http://www.panasonic.ca)), or an authorized Servicentre closest to you.

**Conexión a un televisor**

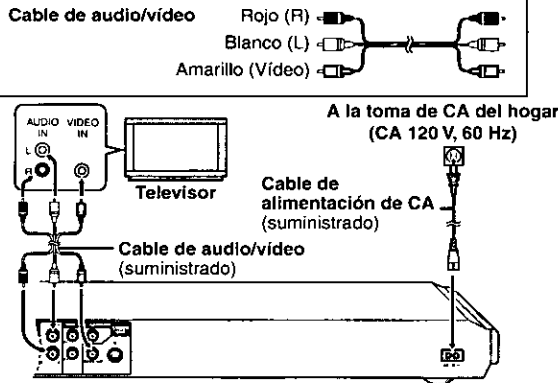

**Para disfrutar de vídeo progresivo**

Haga la conexión a los terminales de entrada de vídeo componente (480P) de una televisión compatible con el sistema de protección contra el copiado de esta unidad. (La imagen no se verá correctamente si se hace la conexión a una televisión incompatible.)

**Preparación Rápida**

La pantalla **QUICK SETUP** aparece cuando usted pulsa [SETUP] por primera vez después de adquirir el aparato y le ayuda a efectuar los ajustes necesarios.

- 1 Pulse [⏻] para encender el aparato.
- 2 Pulse [SETUP] para visualizar la pantalla "QUICK SETUP".
- 3 Pulse [▲, ▼] para seleccionar "Español" y pulse [ENTER].
- 4 Pulse [▲, ▼] para seleccionar "Sí" y pulse [ENTER].
- 5 Pulse [▲, ▼] para seleccionar el elemento y pulse [ENTER].
  - Idioma de audio
  - Idioma de los subtítulos
  - Aspecto de su televisor
  - Salida progresiva
  - XP50 Altoparlantes
- 6 Pulse [ENTER] y luego [SETUP] para finalizar los ajustes.

•Para volver a la pantalla anterior, pulse [RETURN].

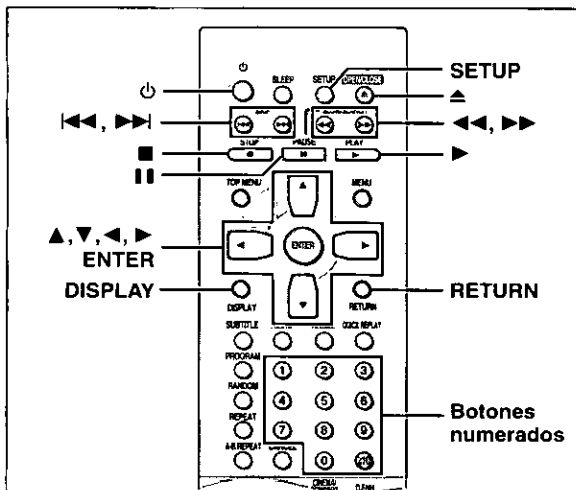

Las operaciones descritas en esta referencia rápida se llevan a cabo con el mando a distancia, pero usted puede hacer también estas operaciones en el aparato principal si los controles son los mismos.

**Reproducción básica**

RAM DVD-A DVD-V VCD CD WMA MP3

**Preparación**

Encienda el televisor y seleccione en él la entrada de vídeo apropiada según las conexiones del reproductor.

- 1 Pulse [⏻] para encender el aparato.
- 2 Pulse [▲] para abrir la bandeja del disco y coloque el disco.
- 3 Pulse [▶] (PLAY).

La bandeja del disco se cierra y la reproducción empieza.

**Para detener la reproducción**

- Pulse [■] (consulte Función de reanudación indicada más abajo).  
**Para hacer una pausa**  
 Pulse [⏸].  
 Pulse [▶] (PLAY) para reanudar la reproducción.

**Para disfrutar del vídeo progresivo**

**Preparación**

- Haga la conexión a través de los terminales COMPONENT VIDEO OUT (→ página 6).
- En QUICK SETUP (o en los menús SETUP → página 21), ponga "Salida progresiva" en "Activar".

1. Pulse [DISPLAY] para visualizar la información del aparato.



2. Mientras se resalta el icono del extremo izquierdo, pulse [▲, ▼] para seleccionar el menú de imágenes.



Modo de salida de vídeo

3. Pulse [◀, ▶] para seleccionar el modo de salida de vídeo.
4. Pulse [▲, ▼] para seleccionar "480P" y para que se encienda el indicador "PROG. OUT" en el visualizador del aparato.



**Nota**

Aunque se encienda el indicador "PROG.OUT" en el visualizador del aparato, la salida sólo se intercalará si usted ha conectado el aparato a su televisor a través de los terminales VIDEO OUT o S VIDEO OUT.

**■ Cuando una pantalla de menú aparece en el televisor DVD-A DVD-V VCD**

Pulse los botones numerados para seleccionar un elemento.

**■ Función de reanudación**

**Parada-reanudación**

El aparato memoriza la posición en la que usted detuvo la reproducción hasta que usted abre la bandeja del disco o pone el aparato en el modo de espera.

**Para reanudar la reproducción**

Pulse [▶] (PLAY) mientras parpadea "▶" en el visualizador del aparato.

**■ Salto de elementos**

Durante la reproducción o durante la pausa  
 Pulse [◀◀] o [▶▶].

**■ Avance rápido y rebobinado—SEARCH**

Durante la reproducción  
 Pulse [◀◀] o [▶▶].

**■ Reproducción a cámara lenta**

RAM DVD-A DVD-V VCD  
 Durante la pausa  
 Pulse [◀◀] o [▶▶].

**■ Visión cuadro a cuadro** RAM DVD-A DVD-V VCD

Durante la pausa  
 Pulse [◀] o [▶].

•Pulse [▶] (PLAY) para iniciar la reproducción.

ESPAÑOL

# Specifications

**Signal system:** NTSC  
**Operating temperature range:** +5 to +35 °C (+41 to +95 °F)  
**Operating humidity range:** 5 to 90 % RH (no condensation)

**Discs played [8 cm (3") or 12 cm (5")]:**

- (1) DVD-RAM (DVD-VR compatible) **XP50**
- (2) DVD-Audio **XP50**
- (3) DVD-Video
- (4) DVD-R (DVD-Video compatible)
- (5) CD-Audio (CD-DA)
- (6) Video CD
- (7) CD-R/CD-RW (CD-DA, Video CD formatted discs)
- (8) WMA/MP3
  - Maximum number of tracks and groups recognizable:  
999 tracks and 99 groups
  - Compatible compression rate:
    - WMA: between 48 kbps and 192 kbps
    - MP3: between 32 kbps and 320 kbps

**Video output:**

Output level: 1 Vp-p (75 Ω)  
Output connector: Pin jack  
Number of connectors: 1 system

**S video output:**

Y output level: 1 Vp-p (75 Ω)  
C output level: 0.286 Vp-p (75 Ω)  
Output connector: S terminal  
Number of connectors: 1 system

**Component video output (480P/480i):**

Y output level: 1 Vp-p (75 Ω)  
P<sub>B</sub> output level: 0.7 Vp-p (75 Ω)  
P<sub>R</sub> output level: 0.7 Vp-p (75 Ω)  
Output connector: Pin jack  
(Y: green, P<sub>B</sub>: blue, P<sub>R</sub>: red)  
Number of connectors: 1 system

**Audio output:**

Output level: 2 Vrms (1 kHz, 0 dB)  
Output connector: Pin jack  
Number of connectors:

- 2 channel: 1 system
- 5.1-channel discrete output (5.1 channel) **XP50**: 1 system
- Subwoofer output (0.1 channel) **XP30**: 1 system

**Audio performance:**

- (1) Frequency response:
  - DVD (linear audio): 4 Hz–22 kHz (48 kHz sampling)  
4 Hz–44 kHz (96 kHz sampling)  
4 Hz–88 kHz (192 kHz sampling)
  - DVD-Audio **XP50**: 4 Hz–20 kHz
  - CD audio: 4 Hz–20 kHz
- (2) S/N ratio:
  - CD audio: 115 dB
- (3) Dynamic range:
  - DVD (linear audio): 102 dB
  - CD audio: 98 dB
- (4) Total harmonic distortion:
  - CD audio: 0.0025 %

**Digital audio output:**

Optical digital output: Optical terminal  
**Pickup:** Wave length: 658 nm/790 nm  
Laser power: CLASS IIa/CLASS I

**Power supply:**

AC 120 V, 60 Hz

**Power consumption:**

14 W  
430 (W)×300 (D)×52 (H) mm  
[16<sup>1</sup>/<sub>16</sub>" (W)×11<sup>3</sup>/<sub>16</sub>" (D)×2<sup>1</sup>/<sub>16</sub>" (H)]  
(excluding protrusions)

**Mass:**

2.9 kg (6.4 lb.)

**Power consumption in standby mode: approx. 2 W**

**Note**

Specifications are subject to change without notice.  
Mass and dimensions are approximate.

Manufactured under license from Digital Theater Systems, Inc. US Pat. No. 5,451,942, 5,956,674, 5,974,380, 5,978,762 and other world-wide patents issued and pending. "DTS" and "DTS Digital Surround" are registered trademarks of Digital Theater Systems, Inc. © 1996, 2000 Digital Theater Systems, Inc. All rights reserved.

Manufactured under license from Dolby Laboratories. "Dolby", "Pro Logic" and the double-D symbol are trademarks of Dolby Laboratories.

Apparatus Claims of U.S. Patent Nos. 4,631,603, 4,577,216, and 4,819,098, licensed for limited viewing uses only.

This product incorporates copyright protection technology that is protected by method claims of certain U.S. patents and other intellectual property rights owned by Macrovision Corporation and other rights owners. Use of this copyright protection technology must be authorized by Macrovision Corporation, and is intended for home and other limited viewing uses only unless otherwise authorized by Macrovision Corporation. Reverse engineering or disassembly is prohibited.

**Panasonic Consumer Electronics Company, Division of Matsushita Electric Corporation of America**  
One Panasonic Way Secaucus, New Jersey 07094  
<http://www.panasonic.com>

**Panasonic Sales Company, Division of Matsushita Electric of Puerto Rico, Inc. ("PSC")**  
Ave. 65 de Infantería, Km. 9.5  
San Gabriel Industrial Park, Carolina, Puerto Rico 00985

**Panasonic Canada Inc.**  
5770 Ambler Drive  
Mississauga, Ontario  
L4W 2T3  
[www.panasonic.ca](http://www.panasonic.ca)

