

**SONY**<sup>®</sup>

4-075-727-21



**FD Trinitron**  
**WEGA**<sup>™</sup>

**XBR**

**DRC-MF**  
Digital Reality Creation

**Operating Instructions**

**KV-32XBR400 KV-36XBR400**

## WARNING

To reduce the risk of fire or shock hazard, do not expose the TV to rain or moisture.

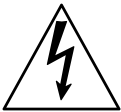
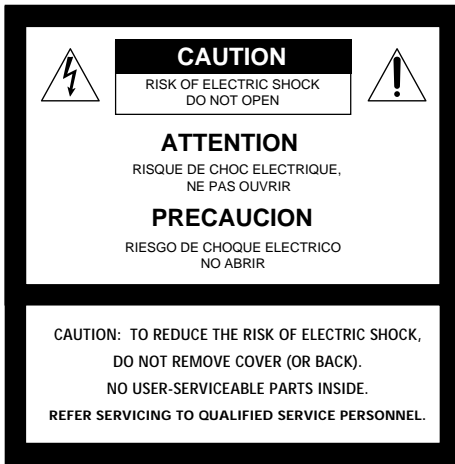

This symbol is intended to alert the user to the presence of uninsulated "dangerous voltage" within the product's enclosure that may be of sufficient magnitude to constitute a risk of electric shock to persons.



This symbol is intended to alert the user to the presence of important operating and maintenance (servicing) instructions in the literature accompanying the appliance.

## CAUTION

TO PREVENT ELECTRIC SHOCK, MATCH WIDE BLADE OF PLUG TO WIDE SLOT, FULLY INSERT.

## CAUTION

When using TV games, computers, and similar products with your TV, keep the brightness and contrast functions at low settings. If a fixed (non-moving) pattern is left on the screen for long periods of time at a high brightness or contrast setting, the image can be permanently imprinted onto the screen. Continuously watching the same program can cause the imprint of station logos onto the TV screen. These types of imprints are not covered by your warranty because they are the result of misuse.

## Note on Caption Vision

This television receiver provides display of television closed captioning in accordance with §15.119 of the FCC rules.

## Note on Cleaning the TV

Clean the TV with a soft dry cloth. Never use strong solvents such as thinner or benzene, which might damage the finish of the cabinet.

## Note to CATV System Installer

This reminder is provided to call the CATV system installer's attention to Article 820-40 of the NEC that provides guidelines for proper grounding and, in particular, specifies that the cable ground shall be connected to the grounding system of the building, as close to the point of cable entry as practical.

Use of this television receiver for other than private viewing of programs broadcast on UHF or VHF or transmitted by cable companies for the use of the general public may require authorization from the broadcaster/cable company and/or program owner.

## NOTIFICATION

This equipment has been tested and found to comply with the limits for a Class B digital device pursuant to Part 15 of the FCC Rules. These limits are designed to provide reasonable protection against harmful interference in a residential installation. This equipment generates, uses, and can radiate radio frequency energy and, if not installed and used in accordance with the instructions, may cause harmful interference with radio communications. However, there is no guarantee that interference will not occur in a particular installation. If this equipment does cause harmful interference to radio or television reception, which can be determined by turning the equipment off and on, the user is encouraged to try to correct the interference by one or more of the following measures:

- Reorient or relocate the receiving antennas.
  - Increase the separation between the equipment and receiver.
  - Connect the equipment into an outlet on a circuit different from that to which the receiver is connected.
  - Consult the dealer or an experienced radio/TV technician for help.
- You are cautioned that any changes or modifications not expressly approved in this manual could void your authority to operate this equipment.

## Safety

- Operate the TV only on 120 V AC.
- The plug is designed, for safety purposes, to fit into the wall outlet only one way. If you are unable to insert the plug fully into the outlet, contact your dealer.
- If any liquid or solid object should fall inside the cabinet, unplug the TV immediately and have it checked by qualified service personnel before operating it further.

## Installing

- To prevent internal heat buildup, do not block the ventilation openings.
- Do not install the TV in a hot or humid place, or in a place subject to excessive dust or mechanical vibration.
- The AC power cord is attached to the rear of the TV with hooks. Do not attempt to remove the cord from these hooks. Doing so could cause damage to the TV.

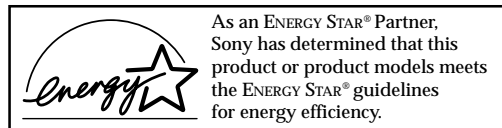

ENERGY STAR® is a U.S. registered mark.

# XBR

● **TruSurround**

TruSurround is a trademark of SRS Labs, Inc. SRS and the SRS symbol are registered trademarks of SRS Labs, Inc. in the United States and selected foreign countries. SRS and TruSurround are incorporated under license from SRS Labs, Inc. and is protected under United States Patent Nos. 4,748,669 and 4,841,572 with numerous additional issued and pending foreign patents. Purchase of this product does not convey the right to sell recordings made with the TruSurround technology.

FD Trinitron and the Wega logo are trademarks of Sony Corporation.

## Owner's Record

The model and serial numbers are provided on the front of this instruction manual and at the rear of the TV. Refer to them whenever you call upon your Sony dealer regarding this product.

# Important Safeguards

For your protection, please read these instructions completely, and keep this manual for future reference.

Carefully observe and comply with all warnings, cautions and instructions placed on the set, or described in the operating instructions or service manual.

## WARNING

To guard against injury, the following basic safety precautions should be observed in the installation, use, and servicing of the set.

## Use

### Power Sources

This set should be operated only from the type of power source indicated on the serial / model plate. If you are not sure of the type of electrical power supplied to your home, consult your dealer or local power company. For those sets designed to operate from battery power, refer to the operating instructions.



### Grounding or Polarization

This set is equipped with a polarized AC power cord plug (a plug having one blade wider than the other), or with a three-wire grounding type plug (a plug having a third pin for grounding). Follow the instructions below:

#### For the set with a polarized AC power cord plug

This plug will fit into the power outlet only one way. This is a safety feature. If you are unable to insert the plug fully into the outlet, try reversing the plug. If the plug should still fail to fit, contact your electrician to have a suitable outlet installed. Do not defeat the safety purpose of the polarized plug by forcing it in.



#### Alternate Warning

#### For the set with a three-wire grounding type AC plug

This plug will only fit into a grounding-type power outlet. This is a safety feature. If you are unable to insert the plug into the outlet, contact your electrician to have a suitable outlet installed. Do not defeat the safety purpose of the grounding plug.

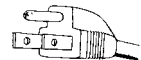

### Overloading

Do not overload wall outlets, extension cords or convenience receptacles beyond their capacity, since this can result in fire or electric shock.

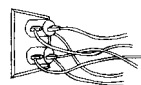

Always turn the set off when it is not to be used. When the set is left unattended and unused for long periods of time, unplug it from the wall outlet as a precaution against the possibility of an internal malfunction that could create a fire hazard.



### Object and Liquid Entry

Never push objects of any kind into the set through the cabinet slots as they may touch dangerous voltage points or short out parts that could result in a fire or electric shock. Never spill liquid of any kind on the set.



## Attachments

Do not use attachments not recommended by the manufacturer, as they may cause hazards.

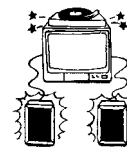

## Cleaning

Unplug the set from the wall outlet before cleaning or polishing it. Do not use liquid cleaners or aerosol cleaners.



Use a cloth lightly dampened with water for cleaning the exterior of the set. If a snapping or popping sound from a TV set is continuous or frequent while the TV is operating, unplug the TV and consult your dealer or service technician. It is normal for some TV sets to make occasional snapping or popping sounds, particularly when being turned on or off.



## Installation

### Water and Moisture

Do not use power-line operated sets near water — for example, near a bathtub, washbowl, kitchen sink, or laundry tub, in a wet basement, or near a swimming pool, etc.

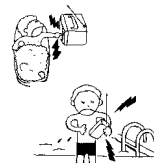

### Accessories

Do not place the set on an unstable cart, stand, table or shelf. The set may fall, causing serious injury to a child or an adult, and serious damage to the set. Use only a cart or stand recommended by the manufacturer for the specific model of TV. An appliance and cart combination should be moved with care. Quick stops, excessive force, and uneven surfaces may cause the appliance and cart combination to overturn.



### Ventilation

The slots and openings in the cabinet and in the back or bottom are provided for necessary ventilation. To ensure reliable operation of the set, and to protect it from overheating, these slots and openings must never be blocked or covered.

- Never cover the slots and openings with a cloth or other materials.
- Never block the slots and openings by placing the set on a bed, sofa, rug or other similar surface.
- Never place the set in a confined space, such as a bookcase, or built-in cabinet, unless proper ventilation is provided.
- Do not place the set near or over a radiator or heat register, or where it is exposed to direct sunlight.



## Power-Cord Protection

Do not allow anything to rest on or roll over the power cord, and do not place the set where the power cord is subject to wear or abuse.



## Antennas

### Outdoor Antenna Grounding

If an outdoor antenna is installed, follow the precautions below. An outdoor antenna system should not be located in the vicinity of overhead power lines or other electric light or power circuits, or where it can come in contact with such power lines or circuits.

WHEN INSTALLING AN OUTDOOR ANTENNA SYSTEM, EXTREME CARE SHOULD BE TAKEN TO KEEP FROM CONTACTING SUCH POWER LINES OR CIRCUITS AS CONTACT WITH THEM IS ALMOST INVARIABLY FATAL. Be sure the antenna system is grounded so as to provide some protection against voltage surges and built-up static charges. Section 810 of the National Electrical Code (NEC) in USA and Section 54 of the Canadian Electrical Code in Canada provides information with respect to proper grounding of the mast and supporting structure, grounding of the lead-in wire to an antenna discharge unit, size of grounding conductors, location of antenna discharge unit, connection to grounding electrodes, and requirements for the grounding electrode.

### Antenna Grounding According to the NEC

Refer to section 54-300 of Canadian Electrical Code for Antenna Grounding.

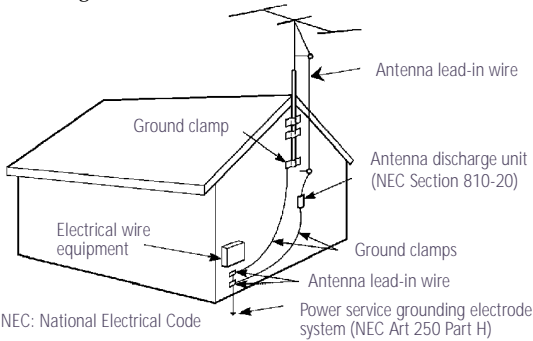

NEC: National Electrical Code

## Lightning

For added protection for this television receiver during a lightning storm, or when it is left unattended and unused for long periods of time, unplug it from the wall outlet and disconnect the antenna. This will prevent damage to the receiver due to lightning and power-line surges.

## Service

### Damage Requiring Service

Unplug the set from the wall outlet and refer servicing to qualified service personnel under the following conditions:

- When the power cord or plug is damaged or frayed.
- If liquid has been spilled into the set.
- If the set has been exposed to rain or water.
- If the set has been subject to excessive shock by being dropped, or the cabinet has been damaged.
- If the set does not operate normally when following the operating instructions. Adjust only those controls that are specified in the operating instructions. Improper adjustment of other controls may result in damage and will often require extensive work by a qualified technician to restore the set to normal operation.
- When the set exhibits a distinct change in performance — this indicates a need for service.

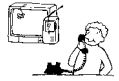
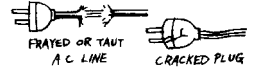

## Servicing

Do not attempt to service the set yourself since opening the cabinet may expose you to dangerous voltage or other hazards. Refer all servicing to qualified service personnel.



## Replacement Parts

When replacement parts are required, be sure the service technician certifies in writing that he has used replacement parts specified by the manufacturer that have the same characteristics as the original parts.

Unauthorized substitutions may result in fire, electric shock, or other hazards.

## Safety Check

Upon completion of any service or repairs to the set, ask the service technician to perform routine safety checks (as specified by the manufacturer) to determine that the set is in safe operating condition, and to so certify. When the set reaches the end of its useful life, improper disposal could result in a picture tube implosion. Ask a qualified service technician to dispose of the set.



---

# Contents

## *Introducing the FD Trinitron Wega*

Overview .....	1
Presenting the FD Trinitron Wega.....	2
Using the Remote Control .....	3

## *Installing the TV*

Overview .....	5
Connecting a Cable or Antenna.....	6
Connecting a VCR and Cable.....	9
Connecting a VCR and Cable Box.....	10
Connecting Two VCRs for Tape Editing.....	11
Connecting a Satellite Receiver.....	12
Connecting a Satellite Receiver with a VCR ...	13
Connecting an Audio Receiver .....	14
Connecting a DVD Player with Component Video Connectors.....	15
Connecting a DVD Player with A/V Connectors .....	16
Connecting a Digital TV Receiver .....	17
Connecting a Camcorder .....	17
Using the CONTROL S Feature.....	18
Setting Up the TV Automatically .....	18

## *Using the Features*

Overview .....	19
Using Favorite Channels.....	20
Using Twin View .....	21
Using the Freeze Function .....	23

## *Using the Menus*

Overview .....	25
Using the Video Menu .....	26
Using the Audio Menu .....	28
Using the Channel Menu.....	30
Using the Parent Menu .....	31
Using the Timer Menu .....	34
Using the Setup Menu.....	35

## *Other Information*

Overview.....	37
TV Controls and Connectors.....	38
Using the Remote Control .....	40
Troubleshooting.....	46
Specifications.....	48
Index .....	51



# Introducing the FD Trinitron Wega

## Overview

This chapter defines the contents of your Wega TV, and provides an overview of how to set up and use basic features.

<i>Topic</i>	<i>Page</i>
Presenting the FD Trinitron Wega	2
Using the Remote Control	3

## Presenting the FD Trinitron Wega

The FD Trinitron Wega (pronounced VAY-GAH) is characterized by outstanding contrast, uncompromising accuracy, and corner-to-corner detail.

You'll recognize the superiority of Wega technology almost immediately. The first thing you'll notice is minimal glare from the flat picture tube. This flat-screen technology improves picture detail without distortion, unlike conventional curved screens. The FD Trinitron delivers outstanding image detail not only at the screen center, but also at the corners — so you can enjoy a bright, clear picture from any location in a room.

---

### Features

Some of the features that you will enjoy with your new TV include:

- ❑ **DRC-MF (Digital Reality Creation, Multi Function):** Unlike conventional line doublers, the DRC feature doubles vertical and horizontal lines, resulting in four times the density for quality sources such as DVD, Satellite and Digital camcorder.
- ❑ **Twin View™:** Using Multi-Image Driver (MIDX), Twin View allows you to watch two programs side by side with the ability to zoom in one picture. You can watch pictures from two different sources (1080i, 480p and 480i) simultaneously.
- ❑ **16:9 Enhancement:** Vertical Compression technology that maximizes picture resolution on “anamorphic” or “enhanced for widescreen” sources, including selected DVDs.
- ❑ **Velocity Modulation:** Vertical line enhancement that sharpens picture definition.
- ❑ **Steady Sound:** Equalizes volume levels so there is consistent output between programs and commercials.
- ❑ **Parental Control:** V-Chip technology allows parents to block unsuitable programming for younger viewers.
- ❑ **Component Video Inputs:** Offers the best video quality for DVD, (480p, 480i) Digital Set-top box (HD1080i) connections.
- ❑ **S-VIDEO Inputs:** Provides a high-quality image for connected equipment.
- ❑ **Favorite Channel Preview:** Preview up to eight favorite channels without leaving the current channel.



## Using the Remote Control

### Inserting Batteries

Insert two size AA (R6) batteries (supplied) by matching the + and - on the batteries to the diagram inside the battery compartment.

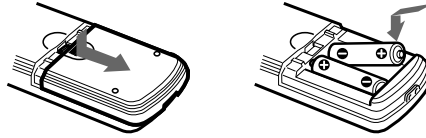



Remove the batteries to avoid damage from possible battery leakage whenever you anticipate that the remote control will not be used for an extended period.

Handle the remote control with care. Avoid dropping it, getting it wet, or placing it in direct sunlight, near a heater, or where the humidity is high.

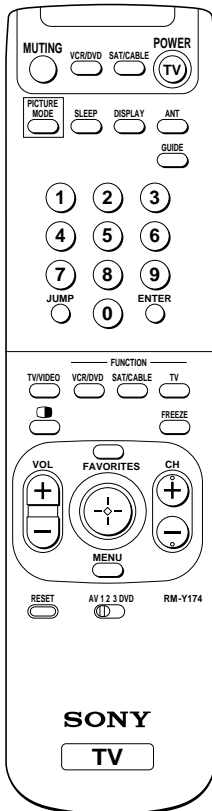
### Remote Control Overview

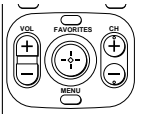

Here's an overview of the buttons on the remote control you will probably use most often. For a complete description of the remote control, see "Using the Remote Control" on page 40.

<i>To Do This ...</i>	<i>Use This Button</i>
Turn the TV on and off	TV (POWER)
Select channels directly	0 – 9 and ENTER Press 0 – 9 to select a channel, the channel changes after 2 seconds. Press ENTER for immediate selection.
Scan through channels	CH +/-  To scan rapidly through the channels, press and hold down the CH+ or CH- button.
Adjust the volume	VOL +/-
Switch video inputs (such as a VCR)	TV/VIDEO Press repeatedly to toggle through all video inputs.
Display the Menu to make changes to the TV	MENU For details, see "Using the Menus" on page 25.
View the Favorite Channels list	FAVORITES For details, see "Using Favorite Channels" on page 20.
Using the on-screen functions	 Move  Select



# Installing the TV

## Overview

This chapter includes illustrated instructions for setting up your TV:

<i>Topic</i>	<i>Page</i>
Connecting a Cable or Antenna	6
Connecting a VCR and Cable	9
Connecting a VCR and Cable Box	10
Connecting Two VCRs for Tape Editing	11
Connecting a Satellite Receiver	12
Connecting a Satellite Receiver with a VCR	13
Connecting an Audio Receiver	14
Connecting a DVD Player with Component Video Connectors	15
Connecting a DVD Player with A/V Connectors	16
Connecting a Digital TV Receiver	17
Using the CONTROL S Feature	18
Setting Up the TV Automatically	18

---

### *Note About the AC Power Cord*

The AC power cord is attached to the rear of the TV with hook. Use caution when removing the AC plug from its holder. Gently slide the plug in the upward direction to remove from hook. Once removed, the AC power plug should automatically disengage from its stored location.

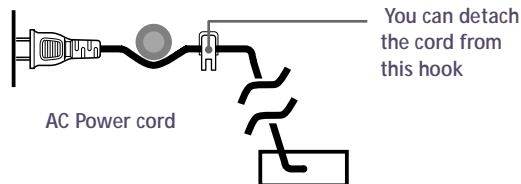

## Connecting a Cable or Antenna

### Connecting Directly to Cable or an Antenna

The connection you choose depends on the cable found in your home. Newer homes are equipped with standard coaxial cable (see **A**); older homes probably have 300-ohm twin lead cable (see **B**); still other homes may contain both (see **C**).

**A** VHF Only or VHF/UHF or Cable

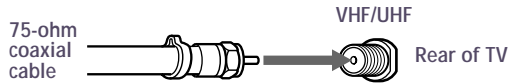

**B** VHF Only or UHF Only or VHF/UHF

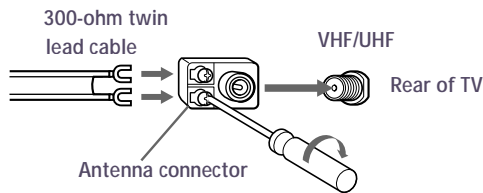

**C** VHF and UHF

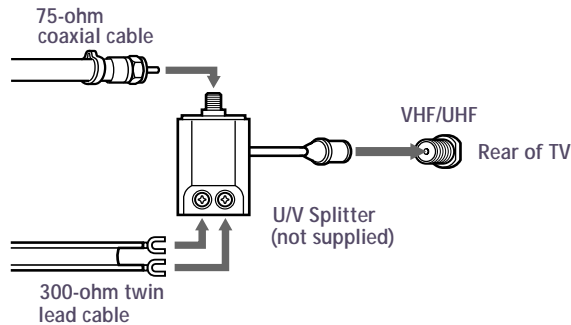

## Cable and Antenna

If your cable provider does not feature local channels, you may find this set up convenient.

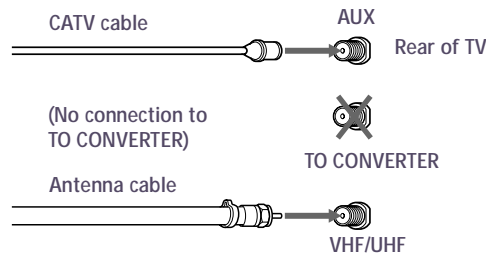

Select **CABLE** or antenna (**ANT**) mode by pressing **ANT** on the remote control.

 In order to receive channels with an antenna, you need to turn your Cable to OFF and perform the Auto Program function (see page 30).

## Cable Box Connections

Some pay cable TV systems use scrambled or encoded signals that require a cable box to view all channels.

### Cable Box

- 1 Connect the coaxial connector from your cable service to the cable box's IN jack.
- 2 Using a coaxial cable, connect the cable box's OUT jack to the TV's VHF/UHF jack.

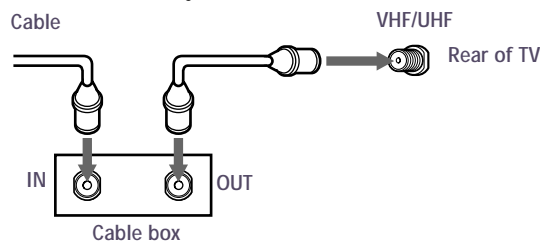

 If you will be controlling all channel selection through your cable box, you should consider using the Channel Fix feature (see page 30).

### Cable Box and Cable

For this set up, you can switch between scrambled channels (through your cable box), and normal (CATV) channels by pressing ANT on the remote control.

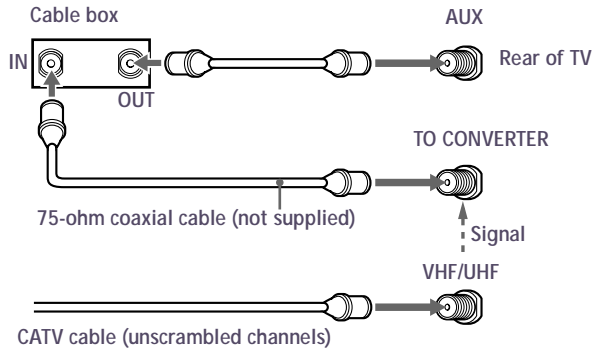

 Your Sony remote control can be programmed to operate your cable box (see "Programming the Remote Control" on page 42).  
When using Favorite Channel or Twin View, you cannot view the AUX input in the window picture.

 Pressing ANT switches between these inputs.

 If you are connecting a cable box through the AUX input and would like to switch between the AUX and normal (CATV) input you should consider using the Channel Fix feature (see page 30).

## Connecting a VCR and Cable

- 1 Connect the cable TV cable to the VCR's IN jack.
- 2 Using a coaxial cable, connect the VCR's OUT jack to the TV's VHF/UHF jack.
- 3 Using an A/V cable, connect the VCR's A/V OUT jacks to the TV's A/V IN jacks.



If your VCR has an S VIDEO jack: For best picture quality, use an S VIDEO connection instead of the yellow video cable on your combined A/V cable. Using an S VIDEO cable, connect the VCR's S VIDEO OUT jack to the TV's S VIDEO IN jack. S VIDEO does not provide audio, so audio cables must still be connected to provide sound.

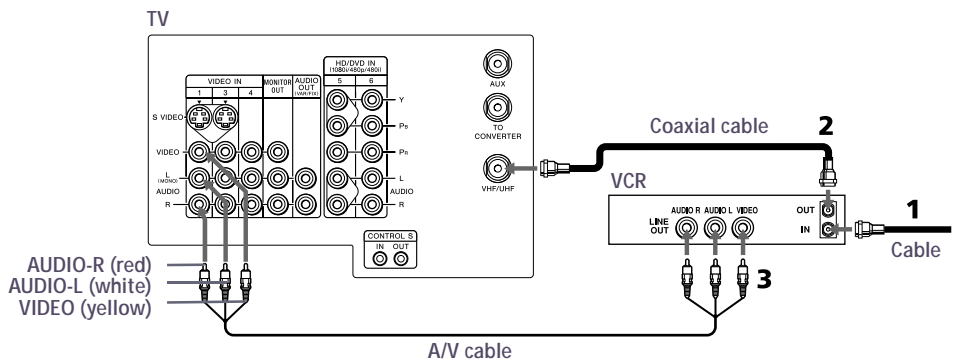

## Connecting a VCR and Cable Box

- 1 Connect the single (input) jack of the splitter to your incoming cable connection, and connect the other two (output) jacks (using coaxial cable) to IN on your cable box and VHF/UHF on your TV.
- 2 Using a coaxial cable, connect the cable box's OUT jack to the VCR's VHF/UHF IN jack.
- 3 Using an A/V cable, connect the VCR's A/V OUT jacks to the TV's A/V IN jacks.

 If your VCR has an S VIDEO jack: For best picture quality, use an S VIDEO connection instead of the yellow video cable on your combined A/V cable. Using an S VIDEO cable, connect the VCR's S VIDEO OUT jack to the TV's S VIDEO IN jack. S VIDEO does not provide audio, so audio cables must still be connected to provide sound.

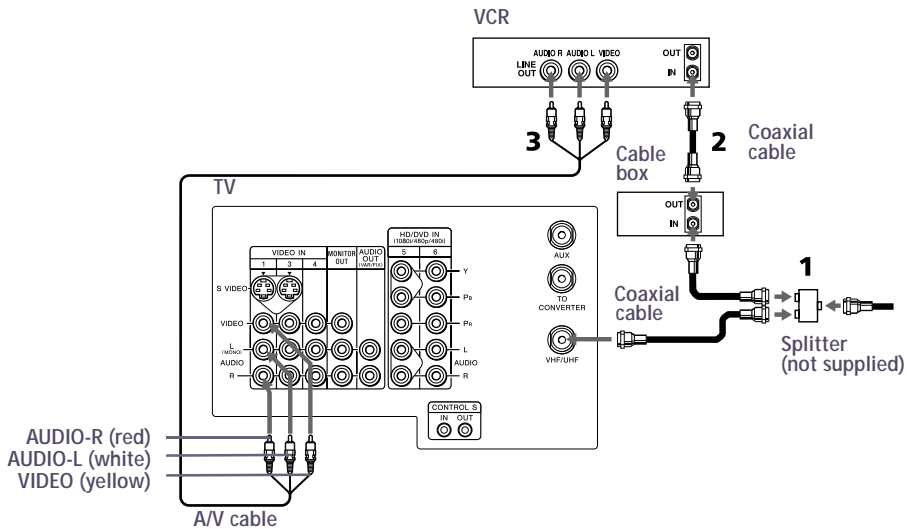





## Connecting Two VCRs for Tape Editing

If you connect two VCRs, you can use the TV's MONITOR OUT feature to perform tape-to-tape editing. In the connection shown below, the TV functions as a monitor and sends the program being played by the playback VCR to the recording VCR.

- 1 Connect the VCR intended for playback using the connection instructions on page 10 of this manual.
- 2 Using A/V connectors, connect AUDIO and VIDEO IN on the VCR intended for recording to MONITOR AUDIO and VIDEO OUT on your TV.

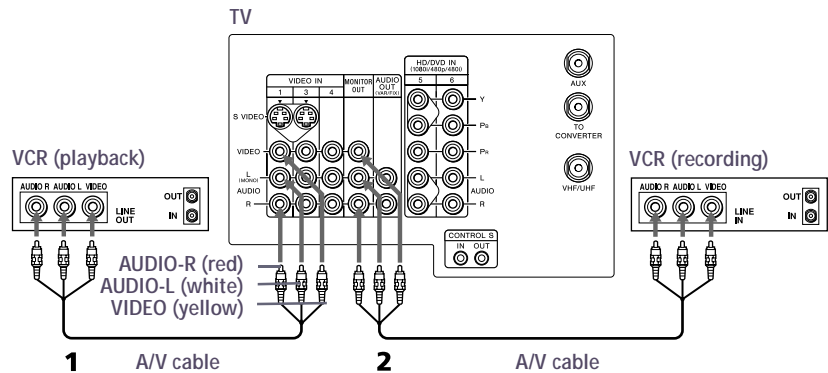
 You cannot record signals from equipment connected to the Y, Pb, Pr input.



 To perform tape editing, set the TV to the video input intended for playback by pressing the TV/VIDEO button on the remote control.

## Connecting a Satellite Receiver

- 1 Connect the satellite antenna cable to the satellite receiver's SATELLITE IN jack.
- 2 Using an A/V cable, connect the satellite receiver's A/V OUT jacks to the TV's A/V IN jacks.
- 3 Connect a coaxial cable from your cable or antenna to the TV's VHF/UHF jack.

 If your satellite receiver has an S VIDEO jack: For best picture quality, use an S VIDEO connection instead of the yellow video cable on your combined A/V cable. Using an S VIDEO cable, connect the satellite receiver's VIDEO OUT jack to the TV's S VIDEO IN jack. S VIDEO does not provide audio, so audio cables must still be connected to provide sound.

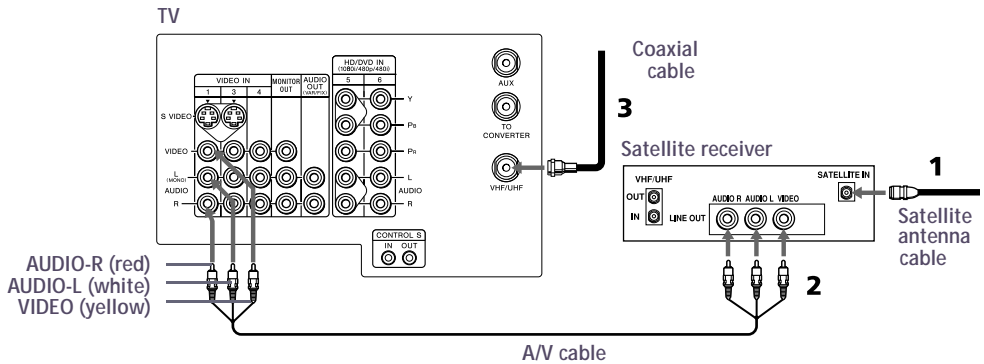

## Connecting a Satellite Receiver with a VCR

- 1 Connect the satellite antenna cable to the satellite receiver's SATELLITE IN jack.
- 2 Connect the CATV cable to the VCR's VHF/UHF IN jack.
- 3 Using a coaxial cable, connect the VCR's OUT jack to the TV's VHF/UHF jack.
- 4 Using an A/V cable, connect the satellite receiver's A/V OUT jacks to the VCR's A/V IN jacks.
- 5 Using an A/V cable, connect the VCR's A/V OUT jacks to the TV's A/V IN jacks.

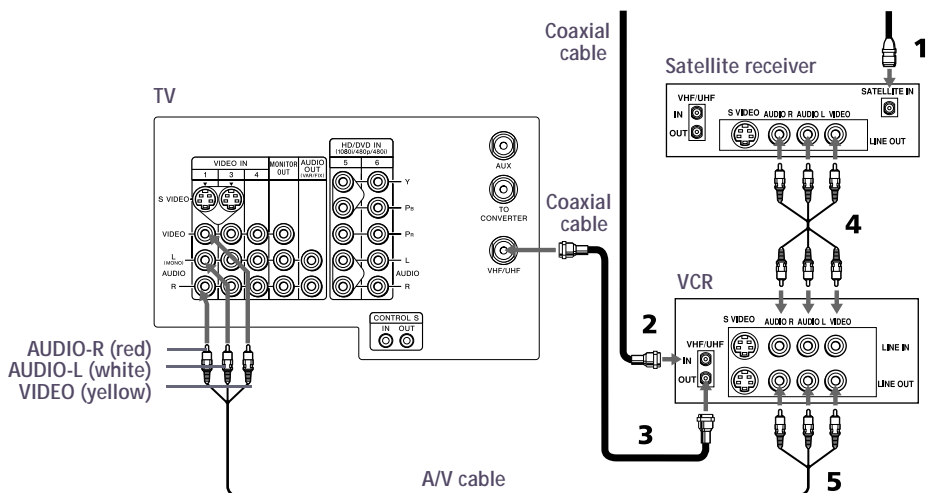

## Connecting an Audio Receiver

- 1 Using audio cables, connect the TV's AUDIO OUT jacks to the audio receiver's audio LINE IN jacks.

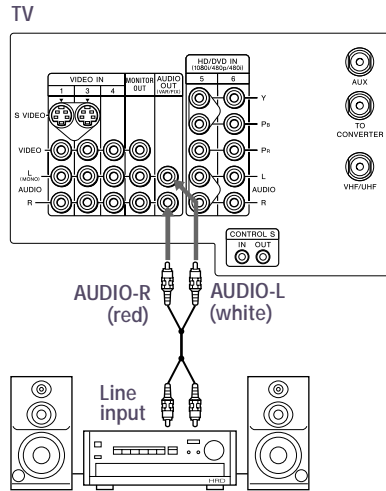

## Connecting a DVD Player with Component Video Connectors

- 1 Using three separate component video cables, connect the DVD player's Y, PB, and PR jacks to the Y, PB, and PR jacks on the TV.

 The Y, PB, and PR jacks on your DVD player are sometimes labeled Y, CB, and CR, or Y, B-Y, and R-Y. If so, connect the cables to like colors.

The Y, PB, and PR jacks do not provide audio, so audio cables must be connected to provide sound.

- 2 Using an audio cable, connect the DVD player's audio OUT jacks to the TV's audio IN jacks.

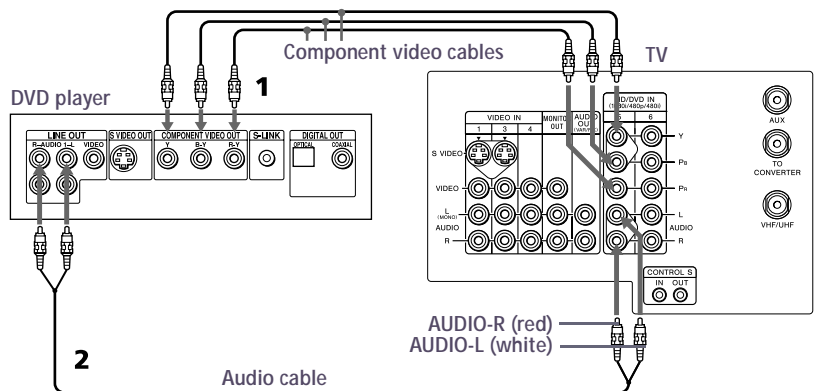

## Connecting a DVD Player with A/V Connectors

 If your DVD player has video component output connectors: for best picture quality use the connection described on page 15.

- 1 Using audio cables, connect the DVD player's audio OUT jacks to the TV's audio IN jacks.
- 2 Using an S VIDEO cable, connect the DVD player's S VIDEO jack to the TV's S VIDEO jack.

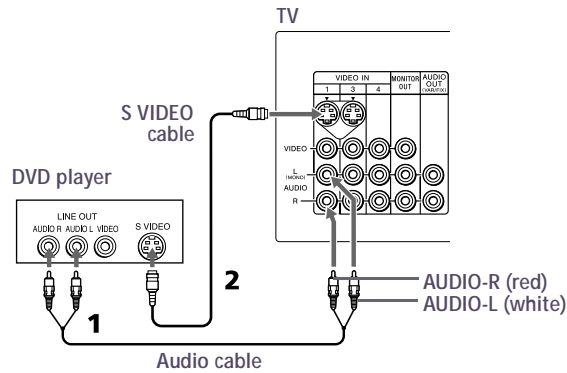

## Connecting a Digital TV Receiver

 Be sure to read the manual for the Set-top box.

- 1 Using three separate component video cables, connect the Digital TV Set-top box's Y, PB, and PR jacks to the TV.

 The Y, PB, and PR jacks do not provide audio, so audio cables must be connected to provide sound.

Component input (Y, PB, and PR) is recommended for optimum picture quality. You may also use component video or S Video connections.

- 2 Using an audio cable, connect the DTV Set-top box's audio OUT jacks to the TV's audio IN jacks.

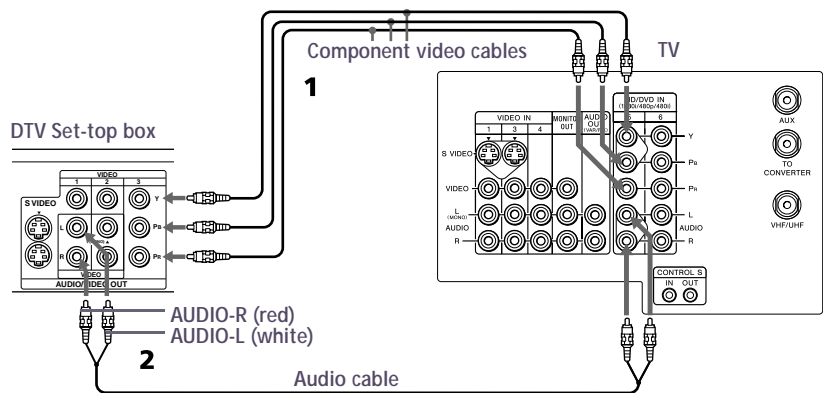

## Connecting a Camcorder

- 1 Using A/V cables, connect the camcorder's A/V OUT jacks to the TV's A/V IN jacks.

 If you have a mono camcorder, connect its left audio output to the TV's AUDIO L jack.

For easy connection of the camcorder, the TV has front A/V inputs (shown below).

However, if you prefer, you can also connect the camcorder to the TV's rear A/V IN jacks.

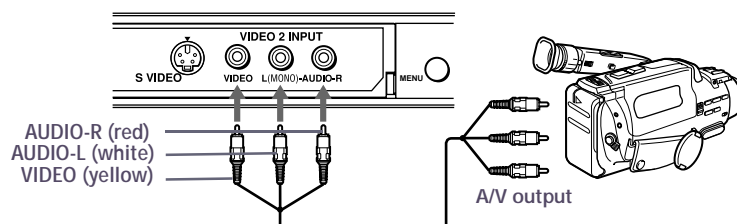

## Using the CONTROL S Feature

CONTROL S allows you to control your TV system and other Sony equipment with one remote control.

To control your other Sony equipment with your TV's remote control, use a CONTROL S cable (not supplied) to connect the equipment's CONTROL S IN jack to the TV's CONTROL S OUT jack.

TV

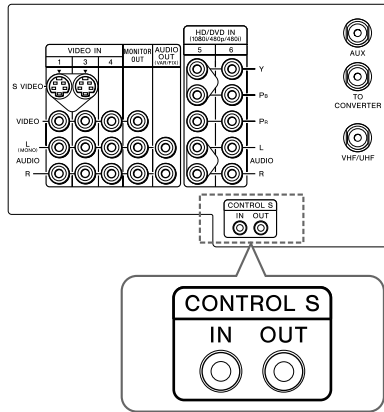

## Setting Up the TV Automatically

After you finish connecting your TV, you need to run Auto Setup to set up your channels.

 The Auto Setup feature does not apply for installations that use a cable box for all channel selection.

### Using Auto Setup

- 1 Press **POWER** to turn on the TV.  
The first time you turn on the TV, the Auto Setup screen appears.
- 2 Press **CH+** to run Auto Setup or press **CH-** to exit.

 You can run Auto Program by selecting it in the Channel menu, as described on page 30.



# Using the Features

## Overview

This chapter describes how to use new features of your TV, including:

<i>Topic</i>	<i>Page</i>
Using Favorite Channels	20
Using Twin View	21
Using the Freeze Function	23

## Using Favorite Channels

The Favorite Channel feature lets you select programs from a list of favorite channels that you specify.



To display a list of your favorite channels:

 You must specify your favorite channels before you can display them. See the Favorite Channel description under "Selecting Channel Options" on page 30.

- 1 Press FAVORITES.

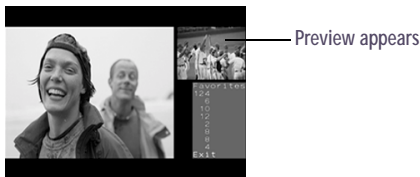
The Favorite Channel options appear.



- 2 Move the joystick  or  to access the channel you want to watch, and press .

## Using Twin View

Twin View enables you to watch two programs at the same time. You can also change the size of both the left and right pictures.

### Displaying Twin Pictures

To display twin pictures

- ❑ Press .



To cancel twin pictures

- ❑ Press  again (or press the  button).

### Activating the Picture

Although two pictures appear on the screen at the same time, only one picture is active. For an active picture, you can:

- ❑ Change channels
- ❑ Adjust the volume
- ❑ Switch the input sources from VHF/UHF to cable by pressing ANT or TV/VIDEO to switch the video input.

To activate the right picture

- ❑ Move the joystick to the right.

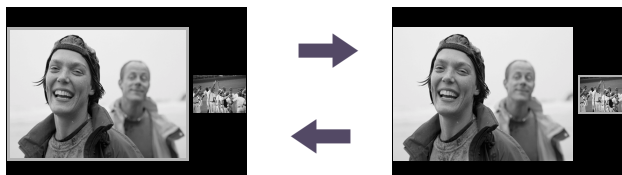

To activate the left picture

- ❑ Move the joystick to the left.

 A blue highlight indicates which is the active picture.

## Changing the Picture Size

The zoom feature lets you change the size of the left and right pictures.

To enlarge the left picture (reduce the right):

- 1 Move the joystick left to activate the left picture (if not already activated).
- 2 Move the joystick up to enlarge the picture.



To enlarge the right picture (reduce the left):

- 1 Move the joystick right to activate the right picture (if not already activated).
- 2 Move the joystick up to enlarge the picture.

 When you adjust the twin screen sizes, the TV memorizes the change. The next time you use the Twin View function, the memorized sizes appear.

## Using the Freeze Function

The FREEZE button allows you to temporarily capture a program's picture. You can use this feature to write down information such as phone numbers, recipes, etc.

To use the FREEZE function

- 1 When the program information you want to capture is displayed, press the FREEZE button.
- 2 The TV switches to Twin View mode and displays the “frozen” picture on the right, while the current program continues on the left.



- 3 To cancel and return to normal viewing, press the FREEZE button.







 Freeze feature is not available if you are already in Twin View mode.



# Using the Menus

## Overview

The Menu gives you access to the following features:

<i>Menu Icon</i>	<i>Description</i>	<i>Page</i>
	Allows you to make adjustments to your picture settings. It also allows you to customize the Picture Mode based on the type of program you are viewing.	26
	Offers enhanced audio options such as listening to second audio programming (SAP), or customizing the Effect of the sound on your TV.	28
	Allows you to set up a Favorite Channel list, run the Auto Program function, and more.	30
	Lets you control the viewing of programs based on their ratings.	31
	Lets you set the clock on your TV and allows you to program your TV for scheduled viewing using the Timers.	34
	Provides several options for setting up your channels, labeling your VIDEO inputs, and selecting the Language of the on-screen menus.	35

 To display the menu or clear it at any time, press MENU.



## Using the Video Menu

To select the Video Menu

- 1 Press MENU.
- 2 Select .



To restore the factory default settings for Picture, Brightness, Color, Hue, and Sharpness

- Press RESET on the remote control when in the Video menu.

### Selecting Video Options

 As a shortcut to using the menus, use the PICTURE MODE button on the remote control to select video modes.

The Video Menu includes the following options.

Option	Description	
Mode	Vivid	
<i>Customized picture viewing</i>	Standard	Select for enhanced picture contrast and sharpness.
	Movie	Recommended for Normal viewing conditions.
	Pro	Select for soft, film like, picture.
		Select for professional monitor like appearance.
	 You can alter the Video Menu settings (Picture, Brightness, Color, etc.) for each Mode.	
Picture	Adjust to increase picture contrast and deepen the color or decrease picture contrast and soften the color.	
Brightness	Adjust to brighten or darken the picture.	
Color	Adjust to increase or decrease color intensity.	
Hue	Adjust to increase or decrease the green tones.	
Sharpness	Adjust to sharpen or soften the picture.	
Color Temp	Choose from three color temperatures:	
<i>White intensity adjustment</i>	Cool	Select to give the white colors a blue tint.
	Neutral	Select to give the white colors a neutral tint.
	Warm	Select to give the white colors a red tint (NTSC-Standard).



<i>Option</i>	<i>Description</i>
VM <i>Velocity Modulation</i>	Sharpens picture definition to give every object a sharp, clean edge. Select from High, Medium, Low, Off.
DRC-MF <i>Digital Reality Creation- Multi Function</i>	Creates a high-resolution picture with 4x density, for high quality sources (i.e. DVD, Satellite). Select from Interlaced, Progressive.
	Interlaced      Recommended for moving pictures.
	Progressive      Recommended for still images and text.



## Using the Audio Menu

To select the Audio Menu

- 1 Press MENU.
- 2 Select .



To restore the factory default settings for Treble, Bass, and Balance

- Press RESET on the remote control when in the Audio menu.

---

### Selecting Audio Options

The Audio Menu includes the following options:

<i>Option</i>	<i>Description</i>
Treble	Adjust to decrease or increase higher-pitched sounds.
Bass	Adjust to decrease or increase lower-pitched sounds.
Balance	Adjust to emphasize left or right speaker balance.
Steady Sound	ON Select to stabilize the volume.
	OFF Select to turn off Steady Sound.
Effect	TruSurround Select for surround sound. (for stereo programs only)
	Simulated Adds a surround-like effect to mono programs.
	OFF Normal stereo or mono reception.

<i>Option</i>	<i>Description</i>	
MTS <i>Enjoy stereo, bilingual and mono programs</i>	Stereo	Select for stereo reception when viewing a program broadcast in stereo.
	Auto-SAP	Select to automatically switch the TV to second audio programs when a signal is received. (If no SAP signal is present, the TV remains in Stereo mode.)
	Mono	Select for mono reception. (Use to reduce noise during stereo broadcasts.)
Speaker	ON	Select to turn on the TV speakers.
	OFF	Select to turn off the TV speakers and listen to the TV's sound only through your external audio system speakers.
Audio Out <i>Easy control of volume adjustments</i>	This option can be set only when the Speaker option is set to OFF.	
	Variable	Sound output varies according to the TV settings. Useful when you want to use the TV's remote control to adjust the output through a separate audio system.
	Fixed	Sound output is held at a fixed level. Use your audio receiver's remote control to adjust the volume.



## Using the Channel Menu

To select the Channel Menu

- 1 Press MENU.
- 2 Select .



### Selecting Channel Options

The Channel Menu includes the following options:

<i>Option</i>	<i>Description</i>
Favorite Channel	Program up to eight of your favorite channels to appear in your Favorite Channel list. To use Favorite Channels, see page 20.
Cable	<p>ON Select if you are receiving cable channels with a CATV cable.</p> <p>OFF Select if you are using an antenna.</p> <p> You should run Auto Program after changing the Cable setting.</p>
Channel Fix	2-6 Select to control all channel selection through a cable box or satellite receiver. Select the appropriate channel number (usually 3 or 4) and use the cable box or satellite receiver's remote control for channel selection.
<i>Useful when you have a cable box or satellite receiver connected</i>	
	AUX 2-6 Select when a cable box or satellite receiver is connected to the AUX input (see page 8). Press the ANT button to alternate between.
	VIDEO 1 Select from available video inputs when you have video equipment connected (e.g. satellite receiver) and you want your TV fixed to it.
Auto Program	Automatically programs the TV for all receivable channels.
Channel Skip/Add	Select to remove or add channels from the channel list when using the CH+/- buttons.
Channel Label	Label up to 20 channels with their station call letters.

 Channels that you set to be skipped can be accessed only with the 0-9 buttons.



## Using the Parent Menu

The Parent Menu allows you to set up the TV to block programs according to their content and rating levels.

To select the Parent Menu

- 1 Press MENU.
- 2 Select .



- 3 When prompted, use the 0-9 buttons on the remote control to enter a four-digit password.
- 4 Confirm your password by entering it again.

 You need this password for any future access into the Parental Control Menu. If you lose your password, see "Lost password" on page 47.

## Using the Parent Menu

 If you are not familiar with the Parental Guideline rating system, you should select Child, Youth, or Young Adult to help simplify the rating selection. To set more restrictive ratings, select Custom.

 For descriptions of Child, Youth, and Young Adult ratings, see page 32.

The Parent Menu includes the following options.

Option	Description
Parental Lock	OFF
<b>Turn ratings on/off and select a rating system</b>	
Child	Parental lock is off. No programs are blocked from viewing. Maximum ratings permitted are: <input type="checkbox"/> US: TV-Y, TV-G, G <input type="checkbox"/> Canada: TV-Y, C, G
Youth	Maximum ratings permitted are: <input type="checkbox"/> US: TV-PG, PG <input type="checkbox"/> Canada: TV-PG, PG, 8 ans+
Young Adult	Maximum ratings permitted are: <input type="checkbox"/> US: TV-14, PG-13 <input type="checkbox"/> Canada: TV-14, 14+, 13 ans+
Custom	Select to set ratings manually. <input type="checkbox"/> US: See page 32 for details. <input type="checkbox"/> Canada: See page 33 for details.
Change Password	For changing your password.

**US Models:  
Selecting Custom  
Rating Options**

 The content ratings will increase depending on the level of the age-based rating. For example, a program with a TV-PG V (Violence) rating may contain moderate violence, while a TV-14 V (Violence) rating may contain more intense violence.

 To ensure maximum blocking capability, the age-based ratings should be blocked.

 If you choose to block unrated TV programs, please be aware that the following programs may be blocked: emergency broadcasts, political programs, sports, news, public service announcements, religious programs and weather.

For US models, the Custom Rating Menu includes the following options. For Canadian models, see page 33.

<i>Option</i>	<i>Description</i>	
Movie Rating	G	All children and General Audience.
	PG	Parental Guidance suggested.
	PG-13	Parental Guidance for children under 13.
	R	Restricted viewing, parental guidance is suggested for children under 17.
	NC-17 and X	No one 17 and under allowed.
TV Rating	Age-Based Options	
<b><i>Block programs by their rating, content or both</i></b>	TV-Y	All children.
	TV-Y7	Directed to older children.
	TV-G	General Audience.
	TV-PG	Parental Guidance suggested.
	TV-14	Parents Strongly cautioned.
	TV-MA	Mature Audience only.
	Content-Based Options	
	FV	Fantasy Violence.
	D	Suggestive Dialogue.
	L	Strong Language.
	S	Sexual situations.
	V	Violence.
Unrated	Block	Blocks all programs and movies that are broadcast without a rating.
	<b><i>Block programs or movies that are broadcast without a rating</i></b>	Allow

---

### *Canadian Models: Selecting Custom Rating Options*

For Canadian models, the Custom Rating Menu includes the following options. For US models, see page 32.

<i>Option</i>	<i>Description</i>	
English Rating	C	All children.
	C8+	Children 8 years and older.
	G	General programming.
	PG	Parental Guidance.
	14+	Viewers 14 and older.
	18+	Adult programming.
French Rating	G	General programming.
	8 ans+	Not recommended for young children.
	13 ans+	Not recommended for ages under 13.
	16 ans+	Not recommended for ages under 16.
	18 ans+	Programming restricted to adults.
USA Rating	See "TV Rating" on page 32 for details.	

---

### *Viewing Blocked Programs*

You can view a blocked program by entering the password. Press the ENTER button when tuned to a blocked program. This temporarily switches off the Parental Lock. To reactivate the Parental Lock settings, turn off the TV. When the TV is turned on again, your Parental Controls settings are reactivated.



## Using the Timer Menu

To select the Timer Menu

- 1 Press MENU.
- 2 Select .



To reset the Clock or Timers

- Press RESET on the remote control when in the adjustment menu.

### Selecting Timer Options

The Timer Menu includes the following options:

<i>Option</i>	<i>Description</i>	
Timer 1	Program	Select to set the Timer by day, time, duration, and channel.
Timer 2	OFF	Select to turn off the Timer. (Your previous settings will be saved.)
Current Time	Set the current time.	
Daylight Savings	ON	Select in the spring to adjust the time during Daylight Saving Time.
	OFF	Select in the fall to adjust the time at the end of Daylight Saving Time.

 Current time must be set before programming timers.





## Using the Setup Menu

To select the Setup Menu

- 1 Press MENU.
- 2 Select .



### Selecting Setup Options

The Setup Menu includes the following options:

<i>Option</i>	<i>Description</i>
Caption Vision	Allows you to select from three closed caption modes (for programs that are broadcast with closed caption).
CC1, CC2, CC3, CC4	Displays a printed version of the dialog or sound effects of a program. (Should be set to CC1 for most programs.)
TEXT1, TEXT2, TEXT3, TEXT4	Displays network/station information presented using either half or the whole screen (if available).
XDS (Extended Data Service)	Displays a network name, program name, program length, and time of the show if the broadcaster offers this service.
OFF	Turns off Caption Vision.
Video Label	Allows you to label your inputs so that you can identify connected equipment. Press TV/VIDEO to cycle through the inputs.
VIDEO 1/2/3/4	VHS, 8mm, Beta, LD, Game, SAT, DVD, Web, Receiver, DTV, Skip
VIDEO 5/6	HD, DVD, DTV, Skip
	If you select Skip, your TV skips this connection when you press the TV/VIDEO button.
Tilt Correction	Allows you to correct any tilt of the picture.
Language	Select from available languages to display all menus in your language of choice.

 To use this feature with widescreen DVDs, set your DVD player to 16:9 aspect ratio.

<i>Option</i>	<i>Description</i>
16:9 Enhanced	Provides enhanced picture resolution for widescreen sources, such as DVD (only available when the TV is in VIDEO mode). Press TV/VIDEO and select from one of the following options:
AUTO	To activate automatically when a 16:9 signal is received.
ON	To activate manually.
OFF	To deactivate.
Demo	Runs a demonstration of on-screen menus.

 AUTO/ON will appear when TV is in video mode 1-6.  
ON/OFF will appear when TV is in VIDEO mode 5-6 and the 480p signal occurs.

# Other Information

## Overview

This chapter includes the following topics:

<i>Topic</i>	<i>Page</i>
TV Controls and Connectors	38
Using the Remote Control	40
Troubleshooting	46
Specifications	48
Index	51

## TV Controls and Connectors

### Front Panel Menu Controls

The front panel menu controls allow access to the on-screen menus without the use of a remote control. Pressing the MENU button brings up the on-screen menus. The arrow buttons move the on-screen cursor in the menus and the (+) button selects the menu item.

 For a description see TV Rear Panel below and Remote Control on page 40

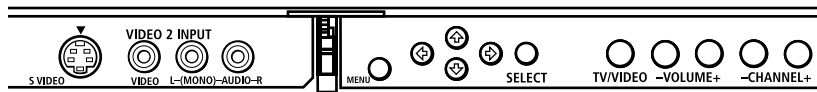

### TV Rear Panel

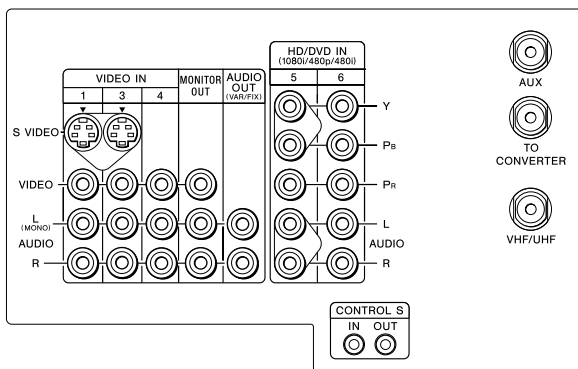

Connection	Description
AUX	Allows you to view local (terrestrial) and cable channels if your cable provider does not feature local channels. You can switch between local and cable channels easily by pressing ANT on the remote control.
TO CONVERTER	Lets you set up your TV to switch between scrambled channels (through a cable box), and normal cable channels (CATV).
VHF/UHF	Connects to your VHF/UHF antenna or cable.
S VIDEO	Connects to the S VIDEO OUT jack of your VCR or other S VIDEO equipped video component.
MONITOR OUT	Lets you record the program you're watching to a VCR. When two VCRs are connected, (see page 11), you can use your TV as a monitor for tape to tape editing. (Not available with 480p, 1080i when input to VIDEO 5, 6)

<i>Connection</i>	<i>Description</i>
VIDEO (L/R)/AUDIO	Connects to the audio and video OUT jacks on your VCR or other video component. A third video input (VIDEO 2) is located on the front panel of the TV.
AUDIO OUT (VAR/FIX) L (MONO)/R	Connects to the right and left audio inputs of your audio or video component.
CONTROL-S IN/OUT	Allows the TV to receive (IN) and send (OUT) remote control signals to other Sony infrared-controlled audio or video components.
HD/DVD IN (1080i, 480p, 480i)	Connects to your DVD player's or Digital Set-top box's component video (Y, PB, PR) and audio (L, R) jacks.

## Using the Remote Control

The following table describes the buttons on the remote control that are for more advanced functions.

 Main Power button must be turned ON to activate the Remote Control.

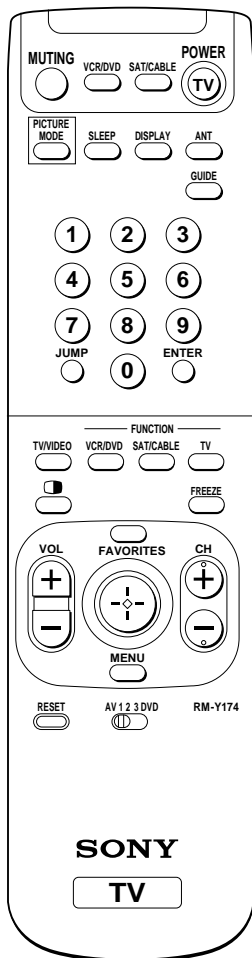

### Button Descriptions



#### Outside Panel





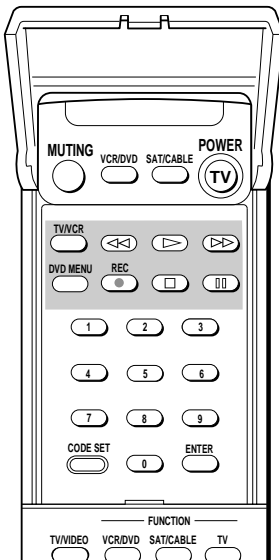

Button	Description
MUTING	Press to mute the sound. Press again or press VOL + to restore the sound.
VCR/DVD (POWER)	Turns the DVD player, MDP player, or VTR (VCR) on and off.
SAT/CABLE (POWER)	Turns the satellite receiver or cable box on and off.
TV (POWER)	Turns the TV on and off.
PICTURE MODE	Press repeatedly to step through the available video picture modes: Vivid, Standard, Pro, Movie. Also available in the Video menu. For details, see “Selecting Video Options” on page 26.
SLEEP	Press repeatedly until the TV displays the time in minutes (15, 30, 45, 60, or 90) that you want the TV to remain on before shutting off automatically. Cancel by pressing until SLEEP OFF appears. While Sleep feature is set, press once to view remaining time
DISPLAY	Press once to display the current time and channel label (if set) and channel number. Press again to turn Display off. See page 34 for details on setting the time.
ANT	Changes the VHF/UHF input to the AUX input.
GUIDE	Displays the program guide of your satellite antenna.
0 – 9 and ENTER	Press 0 – 9 to select a channel, the channel changes after 2 seconds. Press ENTER for immediate selection.
JUMP	Press to jump back and forth between two channels. The TV alternates between the current channel and the last channel that was selected.
TV/VIDEO	Cycles through available video inputs: TV, VIDEO 1, VIDEO 2, VIDEO 3, VIDEO 4, VIDEO 5, VIDEO 6.
VCR/DVD (FUNCTION)	Activates the remote control for use with a DVD player, MDP, or VTR (VCR).
SAT/CABLE (FUNCTION)	Activates the remote control for use with a satellite receiver or cable box.
TV (FUNCTION)	Activates the remote control for use with the TV.

 To scan rapidly through the channels, press and hold down the CH+ or CH- button.

<i>Button</i>	<i>Description</i>
	Turns on/off Twin Mode. For details, see “Using Twin View” on page 21.
FREEZE	Freezes the window picture. Press again to restore the picture.
VOL +/-	Adjusts the volume.
FAVORITES	Displays the Favorite Channels list. For details, see “Using Favorite Channels” on page 20.
CH +/-	Scan through channels.
	Joystick allows for movement of the on-screen cursor. Pressing down on the center of the joystick selects the item.
MENU	Press to display the TV menu. Press again to exit from the menus.
RESET	Resets the TV to the factory default settings for the Video and Audio menus. (Clears setting on Channel and Timer)
AV 1 2 3 DVD 	Use to switch control for connected video equipment. You can program one video source for each switch position (see page 42).



#### Inside Panel

TV/VCR	Changes the VHF/UHF output of the VCR.
	Rewind
	Play
	Fast-forward
DVD MENU	Displays the DVD menu.
REC	Record
	Displays the DVD menu.
	 or  during playback (release to resume normal playback)
0 – 9 and ENTER	Press 0 – 9 to select a VCR channel, the channel changes after 2 seconds. Press ENTER for immediate selection.
CODE SET	Used for programming the remote control to operate non-Sony video equipment. For details, see “Programming the Remote Control” on page 42.

## Programming the Remote Control

The remote control is preset to operate Sony brand video equipment.

<i>Sony Equipment</i>	<i>Switch Position on Remote Control</i>	<i>Programmable Code Number</i>
Beta, ED Beta VCRs	VTR1	303
8 mm VCR	VTR2	302
VHS VCR	VTR3	301
DVD Player	DVD/MDP	751

If you have video equipment other than Sony brand that you want to control with the TV's remote control, use the following procedures to program the remote control.

 The equipment must have infrared (IR) remote capability in order to be used with the remote control.

- 1 Turn to "Programmable Codes" on page 43, and find the three-digit code number for your equipment. If more than one code number is listed, use the number listed first to complete the following procedure.

 You must perform step 3 within 10 seconds of step 2, or you must start again from step 2.

 To check if the code number works, after step 5 aim the TV's remote control at the component and press the POWER button that corresponds with that component. If it responds, you're done. If not, try using the other codes listed for your component.

- 2 Press CODE SET.
- 3 Move the slide switch to the desired input.
- 4 Enter the three-digit code number.
- 5 Press ENTER.

### Tips

- If more than one code number is listed, try entering them one by one until you come to the correct code for your equipment.
- If you enter a new code number, the code number you previously entered at that setting is erased.
- In some rare cases, you may not be able to operate your equipment with the supplied remote control. In this case, use the equipment's own remote control unit.
- Whenever you remove the batteries to replace them, the code numbers may revert to the factory setting and must be reset.



## Programmable Codes

### VCRs

<i>Manufacturer</i>	<i>Code</i>
Sony	301
Admiral (M. Ward)	327
Aiwa	338, 344
Audio Dynamic	314, 337
Broksonic	319, 317
Canon	309, 308
Citizen	332
Craig	302, 332
Criterion	315
Curtis Mathes	304, 338, 309
Daewoo	341, 312, 309
DBX	314, 336, 337
Dimensia	304
Emerson	319, 320, 316, 317, 318, 341
Fisher	330, 335
Funai	338
General Electric	329, 304, 309
Go Video	322, 339, 340
Goldstar	332
Hitachi	306, 304, 305, 338
Instant Replay	309, 308
JC Penney	309, 305, 304, 330, 314, 336, 337
JVC	314, 336, 337, 345, 346, 347
Kenwood	314, 336, 332, 337
LXI (Sears)	332, 305, 330, 335, 338
Magnavox	308, 309, 310
Marantz	314, 336, 337
Marta	332

<i>Manufacturer</i>	<i>Code</i>
Memorex	309, 335
Minolta	305, 304
Mitsubishi/ MGA	323, 324, 325, 326
Multitech	325, 338, 321
NEC	314, 336, 337
Olympic	309, 308
Optimus	327
Panasonic	308, 309, 306, 307
Pentax	305, 304
Philco	308, 309
Philips	308, 309, 310
Pioneer	308
Quasar	308, 309, 306
RCA/ PROSCAN	304, 305, 308, 309, 311, 312, 313, 310, 329
Realistic	309, 330, 328, 335, 324, 338
Sansui	314
Samsung	322, 313, 321
Sanyo	330, 335
Scott	312, 313, 321, 335, 323, 324, 325, 326
Sharp	327, 328
Shintom	315
Signature 2000 (M. Ward)	338, 327
SV2000	338
Sylvania	308, 309, 338, 310
Symphonic	338
Tashiro	332
Tatung	314, 336, 337
Teac	314, 336, 338, 337
Technics	309, 308
Toshiba	312, 311

<i>Manufacturer</i>	<i>Code</i>
Wards	327, 328, 335, 331, 332
Yamaha	314, 330, 336, 337
Zenith	331

### Laserdisc Players

<i>Manufacturer</i>	<i>Code</i>
Panasonic	704, 710
Pioneer	702

### DVD Players

<i>Manufacturer</i>	<i>Code</i>
Sony	751
Panasonic	753
Pioneer	752
RCA	755
Toshiba	754

### Cable Boxes

<i>Manufacturer</i>	<i>Code</i>
Hamlin/Regal	222, 223, 224, 225, 226
Jerrold/G. I.	201, 202, 203, 204, 205, 206, 207, 208, 218
Oak	227, 228, 229
Panasonic	219, 220, 221
Pioneer	214, 215
Scientific Atlanta	209, 210, 211
Tocom	216, 217
Zenith	212, 213

### Satellite Receivers

<i>Manufacturer</i>	<i>Code</i>
Sony	801
General Electric	802
Hitachi	805
Hughes	804
Panasonic	803
RCA/ PROSCAN	802, 808
Toshiba	806, 807

---

## Operating a VCR

<i>To Do This ...</i>	<i>Press</i>
Turn on/off	VTR/DVD (POWER)
Change channels	CH +/-
Record	▶ and REC simultaneously.
Play	▶
Stop	■
Fast forward	▶▶
Rewind the tape	◀◀
Pause	(press again to resume normal playback)
Search the picture forward or backward	▶▶ or ◀◀ during playback (release to resume normal playback)
Change input mode	TV/VCR

---

## Operating an MDP (Laserdisc Player)

<i>To Do This ...</i>	<i>Press</i>
Turn on/off	VCR/DVD (POWER)
Play	▶
Stop	■
Pause	(press again to resume normal playback)
Search the picture forward or backward	▶▶ or ◀◀ during playback (release to resume normal playback)
Search a chapter forward or backward	CH +/-

---

## Operating a Satellite Receiver

<i>To Do This ...</i>	<i>Press</i>
Turn on/off	SAT/CABLE (POWER)
Select a channel	0-9 buttons, ENTER
Change channels	CH +/-
Back to previous channel	JUMP
Display channel number	DISPLAY
Display DBS guide	GUIDE
Display DBS menu	MENU
Move highlight (cursor)	Joystick or arrows
Select item	↔ button

---

## Operating a DVD Player

<i>To Do This ...</i>	<i>Press</i>
Turn on/off	VTR/DVD (POWER)
Play	▶
Stop	■
Pause	⏸ (press again to resume normal playback)
Step through different tracks of an audio disc	▶▶ to step forward or ◀◀ to step backward
Step through different chapters of a video disc	CH+ to step forward or CH- to step backward
Display the DVD menu	DVD MENU
Select tracks directly	0-9 buttons
Display the menu (Setup)	MENU

---

## Operating a Cable Box

<i>To Do This ...</i>	<i>Press</i>
Turn on/off	SAT/CABLE (POWER)
Select a channel	0-9 buttons, ENTER
Change channels	CH +/-
Back to previous channel	JUMP

## Troubleshooting

<i>Problem</i>	<i>Possible Remedies</i>
No picture (screen not lit), no sound	<ul style="list-style-type: none"><li><input type="checkbox"/> If your TV does not turn on, and a red light keeps flashing, your TV may need service. Call your local Sony Service Center.</li><li><input type="checkbox"/> Make sure the power cord is plugged in.</li><li><input type="checkbox"/> Push the power button on the front of the TV.</li><li><input type="checkbox"/> Check to see if the TV/VIDEO setting is correct: when watching TV, set to TV, and when watching connected equipment, set to VIDEO 1, 2, 3, 4, 5 or 6.</li><li><input type="checkbox"/> Try another channel. It could be station trouble.</li></ul>
Remote control does not operate	<ul style="list-style-type: none"><li><input type="checkbox"/> Batteries could be weak. Replace the batteries.</li><li><input type="checkbox"/> Press TV (FUNCTION) when operating your TV.</li><li><input type="checkbox"/> Make sure the TV's power cord is connected securely to the wall outlet.</li><li><input type="checkbox"/> Locate the TV at least 3-4 feet away from fluorescent lights.</li><li><input type="checkbox"/> Check the orientation of the batteries.</li></ul>
Dark, poor or no picture (screen lit), good sound	<ul style="list-style-type: none"><li><input type="checkbox"/> Adjust the Picture setting in the Video menu (see page 26).</li><li><input type="checkbox"/> Adjust the Brightness setting in the Video menu (see page 26).</li><li><input type="checkbox"/> Check antenna/cable connections.</li></ul>
Good picture, no sound	<ul style="list-style-type: none"><li><input type="checkbox"/> Press MUTING so that "MUTING" disappears from the screen (see page 40).</li><li><input type="checkbox"/> Make sure Speaker is set to ON in the Audio menu (see page 28).</li></ul>
Cannot receive upper channels (UHF) when using an antenna	<ul style="list-style-type: none"><li><input type="checkbox"/> Change Cable to OFF (see page 30).</li><li><input type="checkbox"/> Use Auto Program in the Channel menu to add receivable channels that are not presently in TV memory (see page 30).</li></ul>
No color	<ul style="list-style-type: none"><li><input type="checkbox"/> Adjust the Color settings in the Video menu (see page 26).</li></ul>
Only snow and noise appear on the screen	<ul style="list-style-type: none"><li><input type="checkbox"/> Check the antenna/cable connections.</li><li><input type="checkbox"/> Make sure the channel is broadcasting programs.</li><li><input type="checkbox"/> Press ANT to change the input mode (see page 40).</li></ul>
Dotted lines or stripes	<ul style="list-style-type: none"><li><input type="checkbox"/> Adjust the antenna.</li><li><input type="checkbox"/> Move the TV away from noise sources such as cars, neon signs, or hair-dryers.</li></ul>
TV is fixed to one channel	<ul style="list-style-type: none"><li><input type="checkbox"/> Use Auto Program in the Channel menu to add receivable channels that are not presently in TV memory (see page 30).</li><li><input type="checkbox"/> Check your Channel Fix settings (see page 30).</li></ul>
Double images or ghosts	<ul style="list-style-type: none"><li><input type="checkbox"/> Use a highly directional outdoor antenna or a cable (when the problem is caused by reflections from nearby mountains or tall buildings).</li></ul>
Cannot operate menu	<ul style="list-style-type: none"><li><input type="checkbox"/> If the item you want to choose appears in gray, you cannot select it.</li></ul>
Cannot receive any channels when using cable TV	<ul style="list-style-type: none"><li><input type="checkbox"/> Use Auto Program in the Channel menu to add receivable channels that are not presently in TV memory (see page 30).</li><li><input type="checkbox"/> Check your cable settings.</li><li><input type="checkbox"/> Make sure Cable is set to ON in the Channel menu (see page 30).</li></ul>

<i>Problem</i>	<i>Possible Remedies</i>
Cannot gain enough volume when using a cable box	<input type="checkbox"/> Increase the volume of the cable box using the cable box's remote control. Then press TV (FUNCTION) and adjust the TV's volume.
Cannot receive channels	<input type="checkbox"/> Use Auto Program in the Channel menu to add receivable TV channels that are not presently in TV memory (see page 30).
Unable to select a channel	<input type="checkbox"/> Use Auto Program in the Channel menu to add receivable TV channels that are not presently in TV memory (see page 30).
Lost password	<input type="checkbox"/> In the password screen (see page 31), enter the following master password: 4357. The master password clears your previous password; it cannot be used to temporarily unblock channels.

If, after reading these operating instructions, you have additional questions related to the use of your Sony television, please call our Customer Information Services Center at 1-800-222-SONY (7669) (U.S. residents only) or (416) 499-SONY (7669) (Canadian residents only).

# Specifications

## All Models (General)

Picture Tube	FD Trinitron® tube	
Antenna	75 ohm external terminal for VHF/UHF	
Television System	NTSC, American TV Standard	
Channel Coverage		
VHF	2-13	
UHF	14-69	
CATV	1-125	
Power Requirements	120V, 60 Hz	
Number of Inputs/Outputs		
Video (IN)	4	1 Vp-p, 75 ohms unbalanced, sync negative
S Video (IN)	3	Y: 1 Vp-p, 75 ohms unbalanced, sync negative C: 0.286 Vp-p (Burst signal), 75 ohms
Audio (IN)	6	500 mVrms (100% modulation) Impedance: 47 kilohm
Audio (OUT)	1	More than 408 mVrms at the maximum volume setting (Variable) More than 408 mVrms (Fixed) Impedance (output): 2 kilohms
Monitor Out	1	1 Vp-p, 75 ohms unbalanced, sync negative
CONTROL S (IN/OUT)	1	
Component Video Input	2 (Y, P <sub>B</sub> , P <sub>R</sub> )	Y: 1.0 Vp-p, 75 ohms unbalanced, sync negative; P <sub>B</sub> : 0.7 Vp-p, 75 ohms P <sub>R</sub> : 0.7 Vp-p, 75 ohms

## KV-32XBR400

### Supplied Accessories

Remote Control	RM-Y174
AA (R6) Batteries	2 supplied for remote control

### Optional Accessories

AV Cable	VMC-810/820/830 HG
Audio Cable	RKC-515HG
S-LINK Cable	RK-G69HG
Component Video Cable	VMC-10/30 HG
TV Stand	SU-32XBR4A
Visible Screen Size	32 in (812.8 mm) picture measured diagonally
Actual CRT Size	34 in (863.4 mm) picture measured diagonally
Speaker Output	15 x 2
Dimensions (W x H x D)	898.0 x 678.0 x 579.5 mm (35 3/8 x 26 3/4 x 27 7/8 in)
Mass	84 kg (185 lbs)
Power Consumption	
In Use	245 W
In Standby	2 W

## KV-36XBR400

### Supplied Accessories

Remote Control	RM-Y174
AA (R6) Batteries	2 supplied for remote control

### Optional Accessories

AV Cable	VMC-810/820/830 HG
Audio Cable	RKC-515HG
Component Video Cable	VMC-10/30 HG
TV Stand	SU-36XBR4A
Visible Screen Size	36 in (914 mm) picture measured diagonally
Actual CRT Size	38 in (965.2 mm) picture measured diagonally
Speaker Output	15 x 2
Dimensions (W x H x D)	994 x 754.5 x 622 mm (39 1/4 x 29 3/4 x 24 1/2 in)
Mass	108 kg (238 lbs)
Power Consumption	
In Use	245 W
In Standby	2 W

Design and specifications are subject to change without notice.





---

# Index

16:9 (widescreen) 2, 36  
3-D sound, adjusting 28

## A

Antenna, connecting  
Audio menu 25, 28  
Audio receiver, connecting 14  
Auto Program (channel setup) 18, 30

## B

Balance, adjusting 28  
Bass, adjusting 28  
Batteries  
    Inserting in remote 3  
Bilingual audio 29  
Blocking programs. See ratings.  
Brightness, adjusting 26

## C

Cable  
    Box, connecting 7  
    Box, connecting with VCR 10  
    Connecting  
    Setting ON/OFF 30  
    With VCR, connecting 9  
Cable box, using with TV remote control 44  
Camcorder, connecting 17  
Caption Vision 35  
CATV. see cable  
Channel menu 25  
Channel Setup menu 30  
Channels  
    Creating labels 30  
    Setting up 18  
Closed caption modes 35  
Color temperature, adjusting 26  
Color, adjusting 26  
CONTROLS 18

## D

Demo, menus 36  
Digital Reality Creation 27

## DVD player

Using with TV remote control 45  
With A/V connectors, connecting 16  
With component video connectors, connecting  
    15

## E

Enlarging pictures, in Twin View 22  
Extended Data Service 35

## F

Favorite Channel  
    Setting up 30  
    Using 20  
Features 2  
Freeze, using 23

## H

Hue, adjusting 26

## I

Inputs, labeling 35

## L

Label  
    Channels 30  
    Video inputs 35  
Languages, setting for menus 35

## M

MDP, using with TV remote control 44  
Menus  
    Audio 25, 28  
    Channel 25  
    Channel Setup 30  
    Parent 25  
    Parental Control 31  
    Setup 25, 35  
    Timer 25, 34  
    Video 25, 26

## P

Parent menu 25, 31

Parental control, described 2

Password

    Changing 31

    Setting 31

Picture contrast, adjusting 26

Picture definition, adjusting 27

Power cord, removing from holder 5

Presetting channels 30

Problems, troubleshooting 46-47

## R

Ratings, setting 31-33

Ratings, viewing blocked programs 33

Remote control

    Described 40

    Inserting batteries 3

    Overview 3

    Programming 42-43

Resetting

    Audio options 28

    Timer options 34

    Video options 26

## S

Satellite receiver, using with TV remote control

    44

Setting up channels 18

Setup menu 25, 35

Sharpness, adjusting 26

Sound effect (3-D), adjusting 28

Speakers

    Turning on/off 29

    Using external speakers 29

Specifications 48-49

Steady Sound, described 2

Surround sound 28

## T

Tape-to-tape editing 11

Tilt, correcting 35

Timer menu 25, 34

Treble, adjusting 28

Troubleshooting 46-47

Twin View 21

## V

VCR

    Connecting two, for tape editing 11

    Using with TV remote control 44

    With cable box, connecting 10

    With cable, connecting 9

    With satellite receiver, connecting 13

Velocity Modulation 2, 27

Video inputs, labeling 35

Video menu 25, 26

Video Modes, selecting 26

## W

Wega, described 2

Widescreen 36

Widescreen, described 2

## Z

Zoom feature, with Twin View 22



