

# Contents

|   |      |   |    |
|---|------|---|----|
| <b>SAFETY INSTRUCTIONS</b> .....                          | i-ii | <b>Close-up (macro)</b> .....                                     | 34 |
| <b>Components of the camera</b> .....                     | 1    | <b>Selection of optical filter</b> .....                          | 35 |
| How to house the camera in<br>the carrying case .....     | 1    | <b>Selection of video gain</b> .....                              | 35 |
| <b>Features</b> .....                                     | 2    | <b>Adjustment of flange focal distance</b> ...                    | 36 |
| <b>Notes to users</b> .....                               | 4    | <b>Adjustment of black balance</b> .....                          | 37 |
| <b>Name and function of each section</b> .....            | 6    | <b>Adjustment of white balance</b> .....                          | 38 |
| Camera head (Z-2000)<br>and camera adaptor (CA-Z1A) ..... | 6    | <b>Changing settings</b><br>(Function menu operations) .....      | 40 |
| 1.5-inch viewfinder (GM-8) .....                          | 12   | <b>Operating method and</b><br><b>menu screen structure</b> ..... | 40 |
| Zoom lens<br>(Example:A16×9BRM-27) .....                  | 14   | <b>ID setting</b> .....   | 48 |
| <b>How to assemble camera</b> .....                       | 16   | <b>Fine adjustment of AUTO IRIS</b> .....                         | 49 |
| How to mount lens .....                                   | 16   | <b>Electronic shutter</b> .....                                   | 50 |
| How to install 1.5-inch viewfinder .....                  | 17   | <b>Scene files</b> .....  | 52 |
| How to set viewfinder for<br>the best viewing angle ..... | 18   | <b>Genlock</b> .....  | 54 |
| Angle adjustment of eyepiece .....                        | 19   | <b>Viewfinder Display</b> .....                                   | 55 |
| How to install camera adaptor .....                       | 20   | <b>Use in studio system</b> .....                                 | 59 |
| How to install mic .....                                  | 21   | Connection of remote<br>operation unit RU-Z1 .....                | 59 |
| Power supplying to a mic .....                            | 22   | <b>System applications</b> .....                                  | 62 |
| How to install optional<br>battery pack DP-15B .....      | 23   | <b>Specifications</b> .....                                       | 64 |
| How to install BETACAM<br>VTR (BVV-1 or BVV-5) .....      | 24   | <b>Optional accessories</b><br><b>and related equipment</b> ..... | 67 |
| Shoulder pad .....  | 25   | <b>Information for service person</b> .....                       | 69 |
| How to install camera on tripod .....                     | 26   |   |    |
| <b>Connection to VTR</b> .....                            | 27   |   |    |
| Dockable VTRs .....                                       | 27   |   |    |
| How to install VTR .....                                  | 27   |   |    |
| <b>Power supply</b> .....                                 | 29   |   |    |
| <b>Basic shooting procedure</b> .....                     | 30   |   |    |
| <b>Adjustment and operation</b> .....                     | 31   |   |    |
| Adjustment of color monitor .....                         | 31   |   |    |
| Iris control .....  | 32   |   |    |
| Zoom lens<br>[Example: A16×9BRM-27 ] .....                | 33   |   |    |

# Components of the camera

The standard components of the Z-2000 are shown below. Please make sure of the components when unpacking the carton.

How to house the camera in the carrying case.

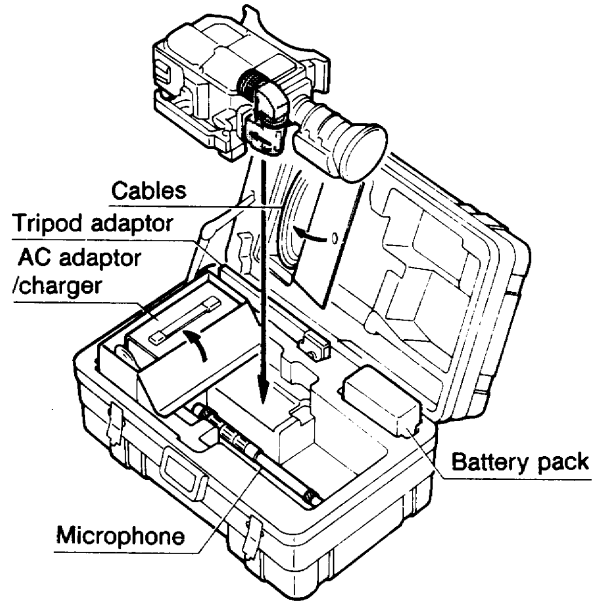
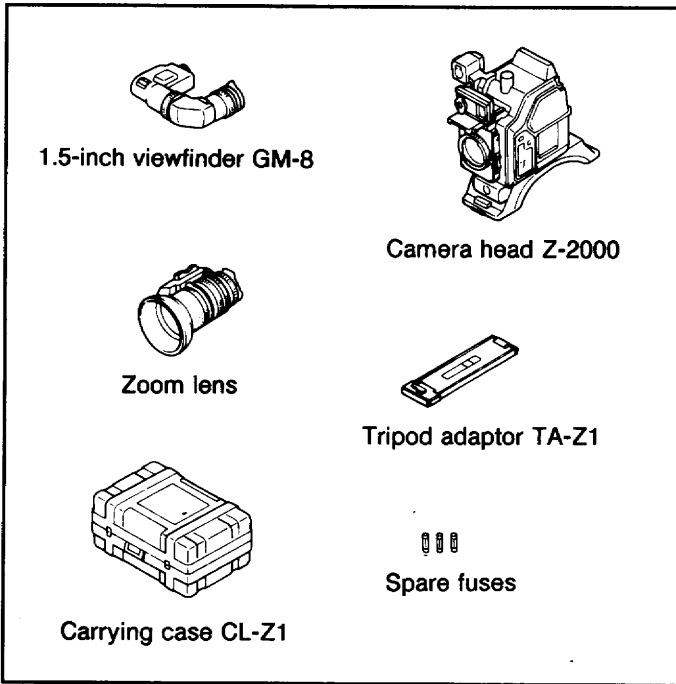

**Note** When storing the camera in the carrying case, move the viewfinder in the direction of arrows.

| Composition                     |                          | B | C |
|---------------------------------|--------------------------|---|---|
| Camera head Z-2000              |                          | X | X |
| Camera adaptor CA-Z1A(Optional) |                          |   |   |
| Zoom Lens                       | 16x (A16X9BRM-27)        | X |   |
|                                 | 17x (YJ17X9.5B4KRS PX12) |   | X |
| 1.5-inch viewfinder GM-8        |                          | X | X |
| Tripod adaptor TA-Z1            |                          | X | X |
| Carrying case CL-Z1             |                          | X | X |
| Spare fuses (three fuses)       |                          | X | X |
| Operation manual                |                          | X | X |

X: Provided

# Features

The Hitachi Z-2000 is a NTSC version 3-CCD portable color camera using a 2/3-inch 400,000-pixel CCD with micro lenses.

The Z-2000 uses the unique digital signal processing technology of 13-bit operation to provide superb picture quality which is not obtained by the conventional analog cameras. Further, high resolution and high signal-to-noise ratio are realized by the high accuracy CCD technology and the low noise circuit technology.

In addition to the portable application, the Z-2000 can be used as an EFP or studio camera, because the Z-2000 is provided with various automatic functions, picture quality control functions and remote control functions by the built-in microprocessor.

## Features

### ■ One-chip ultra LSI for signal processing section

One-chip ultra LSI with 250,000 gates is used for the signal processing section, resulting in compactness and low power consumption.

### ■ 13-bit operation

High signal-to-noise ratio and high dynamic range are realized by the 10-bit A-D converter and the 13-bit operation technology.

### ■ Various picture quality control functions by digital technology

- Flesh tone detail function which improves picture quality by controlling the detail amount of flesh tone. The desired color can also be controlled.
- High chroma detail function which improves the deterioration in resolution of highly saturated objects
- Variable detail boost frequency function
- 6-vector color corrector and conventional linear matrix system
- Special gamma function which permits contrast control for better reproduction of dark areas when shooting high contrast scenes by adjusting the gain of the rising portion of gamma
- Flare correction circuit which provided a crisp picture

### ■ High resolution

850 TV lines of horizontal resolution (at Y channel) by using DSA (Double Sampling Aperture) circuit.

### ■ 1.5 lx of minimum illumination

1.5 lx with a f/1.8 lens is realized by the +24dB high gain mode plus the ULTRA GAIN (+12dB)

function. With this feature, it is possible to shoot low light scenes not possible with conventional CCD cameras.

### ■ A variety of CCD drive functions

- Conventional presettable 5-step electronic shutter
- Lock scan mode which allows to shoot screens with different scanning frequencies without flickers. (For some scanning frequencies, this feature is not available.)
- Auto electronic shutter mode which maintains the video level constant
- CC frame mode which improves vertical resolution

### ■ Extended application fields

- Auto white shading correction function interlocked with a lens extender.
- White balance modes, gain setting data, DTL masking data, gamma values can be set to the four scene files.
- 12 auto white balance memories corresponding to the optical filters and the scene files
- Iris setting level (fine control), and the peak/average values of the iris characteristic can be set on the screen.
- Real-time auto white balance function which corrects white balance by detecting the change in the color temperature of objects
- Camera ID number display function
- Memory back-up by EEPROM (no battery needed)
- Built-in mic amplifier corresponding to 3 kinds of power supplies (DC OFF, MC-C2 and phantom[48V])
- Mic level control provided for a BETACAM VTR

- Filter disc remote-controllable (option)

### ■ Various viewfinder display functions

- Various functions can be set by using the menu screens of tree structure
- Self-diagnosis result display function and status check result display function
- Safety zone and center marking
- Audio indicator
- Remaining tape amount indicator or recording time indicator
- Zebra indication

### ■ High performance viewfinder GM-8

- 600 TV lines of resolution facilitates focussing.
- Easy-to-view angle can be set by the slide and tilt mechanisms.
- Directly coupled with the camera
- Upright positioning available
- Tally lamp on the top cover

### ■ Dockable with various types of VTR

- Directly dockable with a broadcast BETACAM SP VTR
- Dockable with the VTRS listed below via each optional VTR adaptor  
BETACAM Pro(PVV-1), Hi8, MII , MII Promind, S-VHS
- Usable as a self-contained type portable camera by connecting with a VTR with a VTR cable  
Usable VTRs: BETACAM, MII , S-VHS, U-format, etc.

### ■ System operation

- A small-size studio camera can be configured in conjunction with the following units.  
Remote operation unit RU-Z1  
Camera adaptor CA-Z1A  
Camera control panel RC-Z1/RC-Z11  
5-inch viewfinder GM-50
- When the camera is used in conjunction with JU-20 and JU-Z2, the camera can be controlled from a personal computer via the RS-232C interface.  
When JU-Z2 is connected, plural cameras can be controlled from a single personal computer

- The camera can be controlled from the Canon motorized pan/ tilt head(U-4).
- Pictures can be recorded on the VTR with the camera operated in a video system, because the camera can be genlocked, even when the camera is docked with the VTR.

# Notes to users

## ● Power supply

The rated input voltage to the camera is 12V DC. Be sure to use the specified power supply.

- Since precision parts are used inside the camera, do not attempt to open the cover. Do not attempt to touch switches other than specified to avoid possible failure.
- Do not insert a foreign object into the camera. When water, metal chips, etc. are inserted, it may cause failure.
- Avoid using or storing the camera in the following environments to prevent possible damages.
  - Extremely hot or cold place (Operating temperature: -10 to 45°C)
  - Place subjected to strong vibrations
  - Humid or dusty place
  - Environments exposed to salty atmosphere or corrosive gas.
  - Place where strong radio waves are generated (e. g. place near TV or radio transmitting station)
  - Place exposed to rain

## WARNING

### ● Warning on eyepiece of viewfinder

- Never see sunlight or strong light source through the eyepiece to avoid a burn or loss of eyesight.

### ● Viewfinder

- Do not open the cover of the viewfinder.
- Do not touch the inside of the viewfinder to avoid hazard by high voltage.
- Do not leave the camera with the eyepiece facing the sun, Otherwise, sunlight may be focused inside the camera through the eyepiece to cause burning inside the camera.

## ● Caution for transportation

When carrying the camera, use the carrying case.

When transporting the camera, put the camera in the carrying case and then put the case in a carton containing cushioning materials.

## ● Tripod

Use the recommended tripod, and install it in the specified manner (refer to page 26 ).

## ● Maintenance

Clean the lens and the optical filter with a blower.

When the camera body becomes dirty, clean it with a dry, soft cloth. Do not use benzine or thinner to avoid possible deterioration of the material or damage to the paint.

## ● Replacement of fuse

Though this camera is provided with a spare fuse, refer the replacement to qualified service personnel.

If any trouble occur, contact your nearest Hitachi Denshi Service representative.

## .....PHENOMENA INHERENT IN CCD SENSORS.....

The following are the phenomena inherent in CCD sensors and not due to defective CCD sensors.

Use utmost care when a quality picture is required in broadcast applications.

### **Smear**

When a highly bright object is shot, one or more vertical stripes may appear above and below the object. The faster the electronic shutter speed, the stronger this phenomenon.

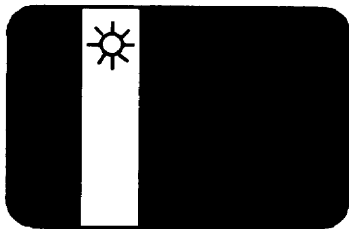

### **Fixed pattern noise**

When the camera is used in a high temperature, fixed pattern noise (vertical stripes or white spots) may appear. When the sensitivity of the camera is increased, fixed pattern noise is easier to see.

# Name and function of each section

## Camera head (Z-2000) and camera adaptor (CA-Z1A)

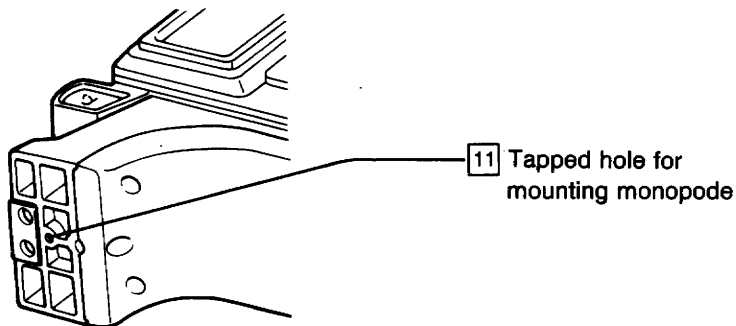
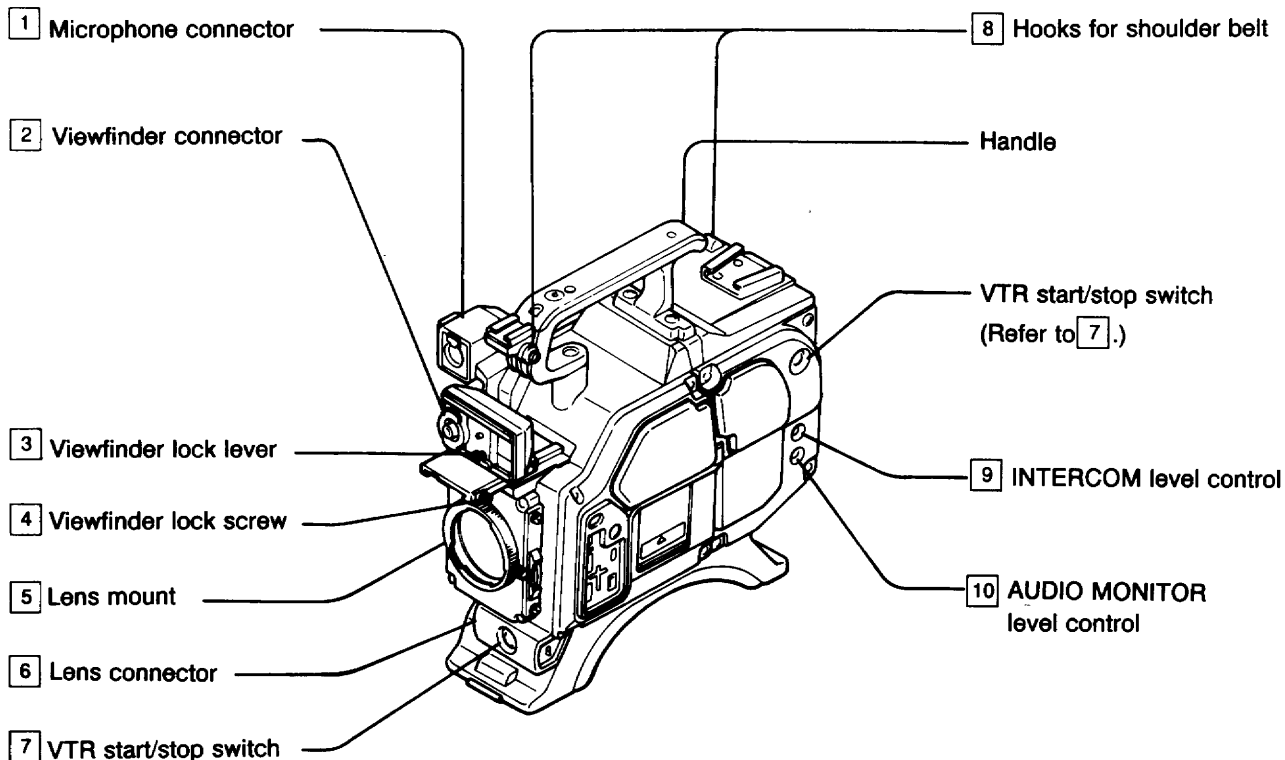

## Name and function of each section

### 1 Microphone connector

Insert the plug of the optional microphone MC-C2.

### 2 Viewfinder connector

Connect the supplied 1.5-inch viewfinder or the optional 5-inch viewfinder GM-50.

### 3 Viewfinder lock lever

Loosen this lever to move the viewfinder sideways.

### 4 Viewfinder lock screw

Loosen this screw to move the 1.5-inch viewfinder back and forth

### 5 Lens mount

Lens mount of the bayonet type (refer to page 16).

### 6 Lens connector [LENS]

Connect the plug of the zoom lens to this connector

Then, the zoom lens is ready to operate.

### 7 VTR start/stop switch

When the camera is connected to a VTR, pressing this switch starts recording and a second press stops recording. When the remote operation unit RU-Z1 is connected, this switch functions as a call button.

### 8 Hooks for shoulder belt

Install the optional shoulder belt SB-1 on these hooks.

### 9 INTERCOM level control

When the remote operation unit RU-Z1 is connected, this control adjust the intercom sound volume.

### 10 AUDIO MONITOR level control

This control adjust the sound volume of the headset and the earphone for audio monitor.

### 11 Tapped hole for mounting monopode

Mount a monopode to this tapped hole (1/4"-20UNC).

**Note:** Do not use this tapped hole to mount the camera on the tripod. To mount the camera on the tripod, use the tripod adaptor TA-Z1.



# Name and function of each section

## Camera head and camera adaptor

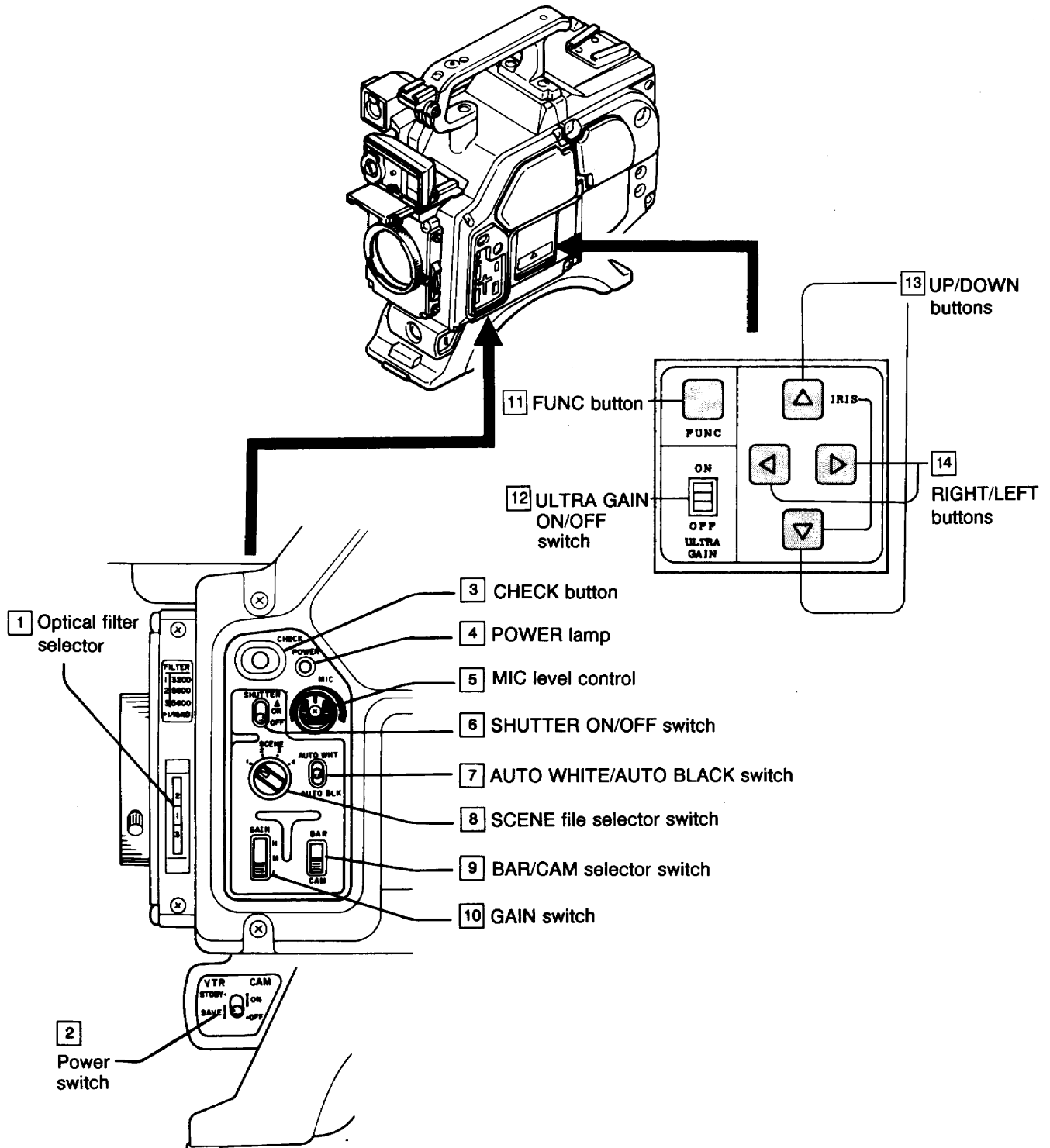

# Name and function of each section

## 1 Optical filter selector

Set to an appropriate filter position.

## 2 Power switch [VRT STDBY/SAVE, CAM ON/OFF]

When this switch is set to VTR STDBY/CAM ON, both the camera and the VTR are turned on and you can start recording.

When this switch is set to VTR SAVE/CAM ON, the camera is turned on and the VTR is in the power save mode.

When this switch is set to VTR SAVE/CAM OFF, the camera is turned off and the VTR is in the power save mode.

## 3 CHECK button

The information on switch settings, recording time and audio level indicator is displayed on the viewfinder.(See pages 55 to 57.)

## 4 Power lamp

Not lit when power is not supplied to the camera.

Lit green when the power switch is turned off with power supplied to the camera.

Lit red when the camera is turned on.

## 5 MIC level control

This control is effective only when a Betacam VTR (BVV-1 or BVV-5) is connected.

## 6 SHUTTER ON/OFF switch

ON: Fast moving objects can be shot with little blur in shutter mode.

OFF: Normal mode shooting

## 7 AUTO WHITE/AUTO BLACK switch

AUTO WHITE:

When the SCENE file selector switch is set to 1, 2, 3 or 4, the optimum white balance is automatically obtained and the data is stored.(See pages 38 and 39)

AUTO BLACK:

The optimum black balance is obtained regardless of the SCENE file selector switch setting, and the data is stored.(See page 37.)

## 8 SCENE file selector switch

This switch selects an appropriate scene file.(See page 52.)

## 9 BAR/CAM selector switch

BAR: The color bar signal is available for the adjustment of peripheral equipment including a color monitor.

CAM: A camera signal is available.

## 10 GAIN switch

Set to an appropriate position in accordance with illumination.

H: The video gain is increased by 18dB ( $\pm$  6dB).

M: The video gain is increased by 9dB ( $\pm$  3dB).

L: Normal gain mode.(For H and M, see page 35.)

## 11 FUNC button

Use this button to change the setting conditions including the detail amount. (See pages 40 to 51)

## 12 ULTRA GAIN ON/OFF switch

ON: Sensitivity is increased by approx. 12dB. (This setting is effective only when sensitivity is more than 12dB, but picture quality including horizontal resolution is lowered.)

OFF: Normal mode operation

## 13 UP/DOWN buttons

Use these buttons to set the optimum value to the item selected by the button 11 (See pages 40 to 51).

In the auto iris mode, use to perform the fine adjustment of the video output signal level.

## 14 RIGHT/LEFT buttons

Use these buttons to set the optimum value to the item selected by the button 11 (See pages 40 to 51).

In the lock scan mode, use this button to adjust a shutter speed.

# Name and function of each section

## Camera head and camera adaptor

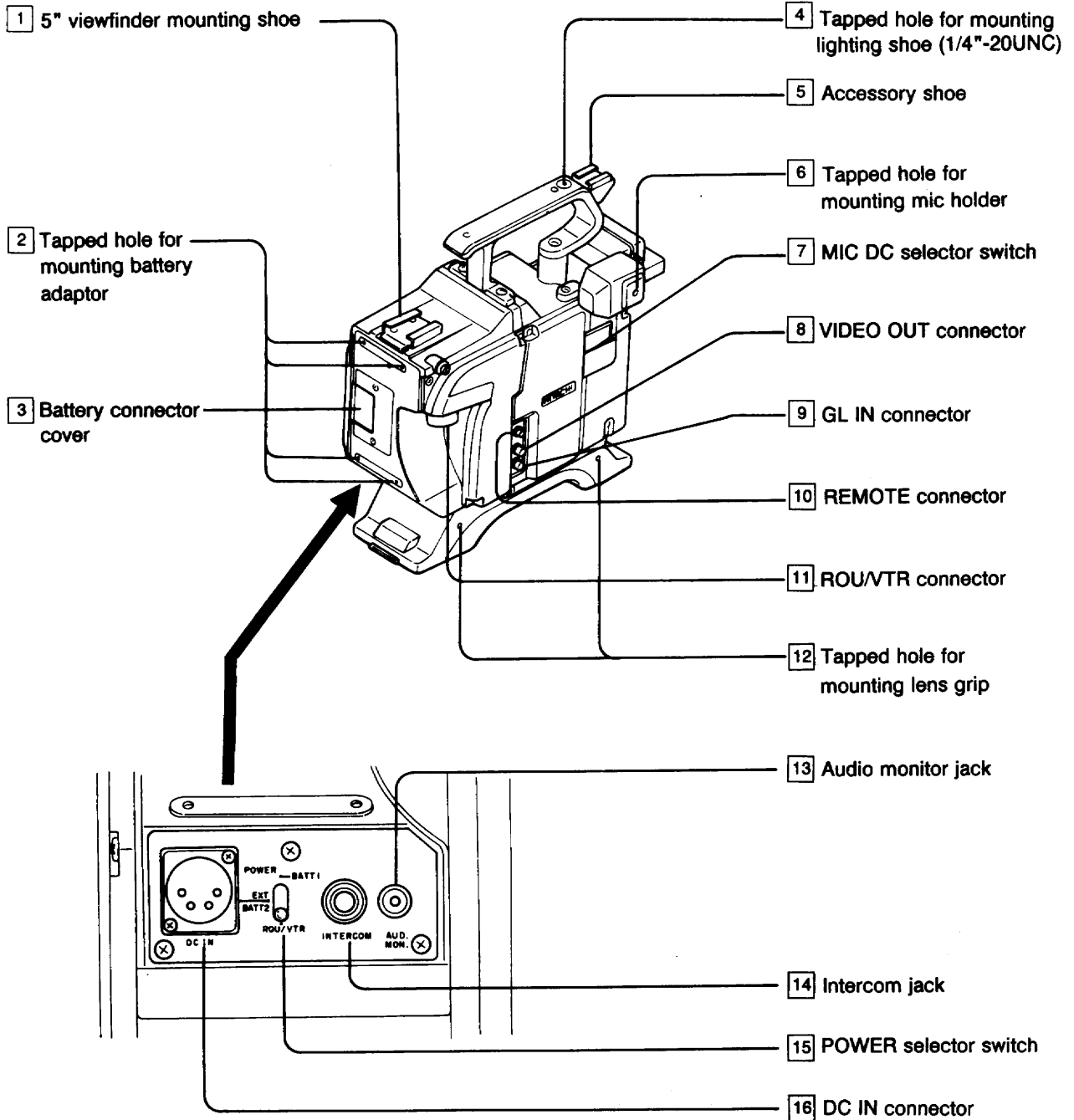

# Name and function of each section

## 1 5" viewfinder mounting shoe

To mount the 5" viewfinder, install the adaptor AT-21A to this shoe first, then mount the viewfinder.

## 2 Tapped hole for mounting battery adaptor

Mount the optional battery adaptor BA-15 when using the optional battery pack DP-15B.

## 3 Battery connector cover [BATT 12V ---- IN]

The special connector for a special battery is accessed by opening this cover.

## 4 Tapped hole for mounting lighting shoe (1/4"-20UNC)

## 5 Accessory shoe

A small-sized illumination lamp can be installed.

## 6 Tapped hole for mounting mic holder

Mount the optional mic holder MH-C1A.

## 7 MIC DC selector switch

Open the cover and set the switches appropriately in accordance with the used VTR and the used mic. (See page 22.)

## 8 Video output connector [VIDEO OUT]

A video signal or the color bar signal (1Vp-p/75 ohms) is fed from this connector.

## 9 GL Input connector [GL IN]

Connect the composite signal or the black burst signal to this connector for genlock operation (refer to page 54).

## 10 Remote connector [REMOTE]

Connect the camera control panel RC-Z1 or RC-Z11, or a personal computer to this connector (refer to page 59.)

## 11 ROU/VTR connector [ROU/VTR]

Connect a portable VTR or the remote operation unit RU-Z1 to this connector, using the optional cable. (refer to pages 27 and 59.)

## 12 Tapped hole for mounting lens grip (1/4"-20UNC)

## 13 AUDIO MON Jack

Plug an earphone (8-10ohms) to monitor the sound from a VTR or a mic.

## 14 Intercom Jack [INTERCOM]

When connecting the remote operation unit RU-Z1 to the camera, plug the headset for intercom into this jack.

## 15 POWER selector switch [BATT-EXT-ROU/NYR]

BATT1: Supply power to the BATT 12V----IN connector.

EXT/BATT2: Supply power to the EXT 12V----IN connector.

ROU/VTR: Connect the remote operation unit or VTR to the ROU/VTR connector (28 pins).

## 16 DC IN connector

Connect the AC adaptor AP-60B or AP-61B or the battery pack DP-15B.

# Name and function of each section

## 1.5-inch viewfinder (GM-8)

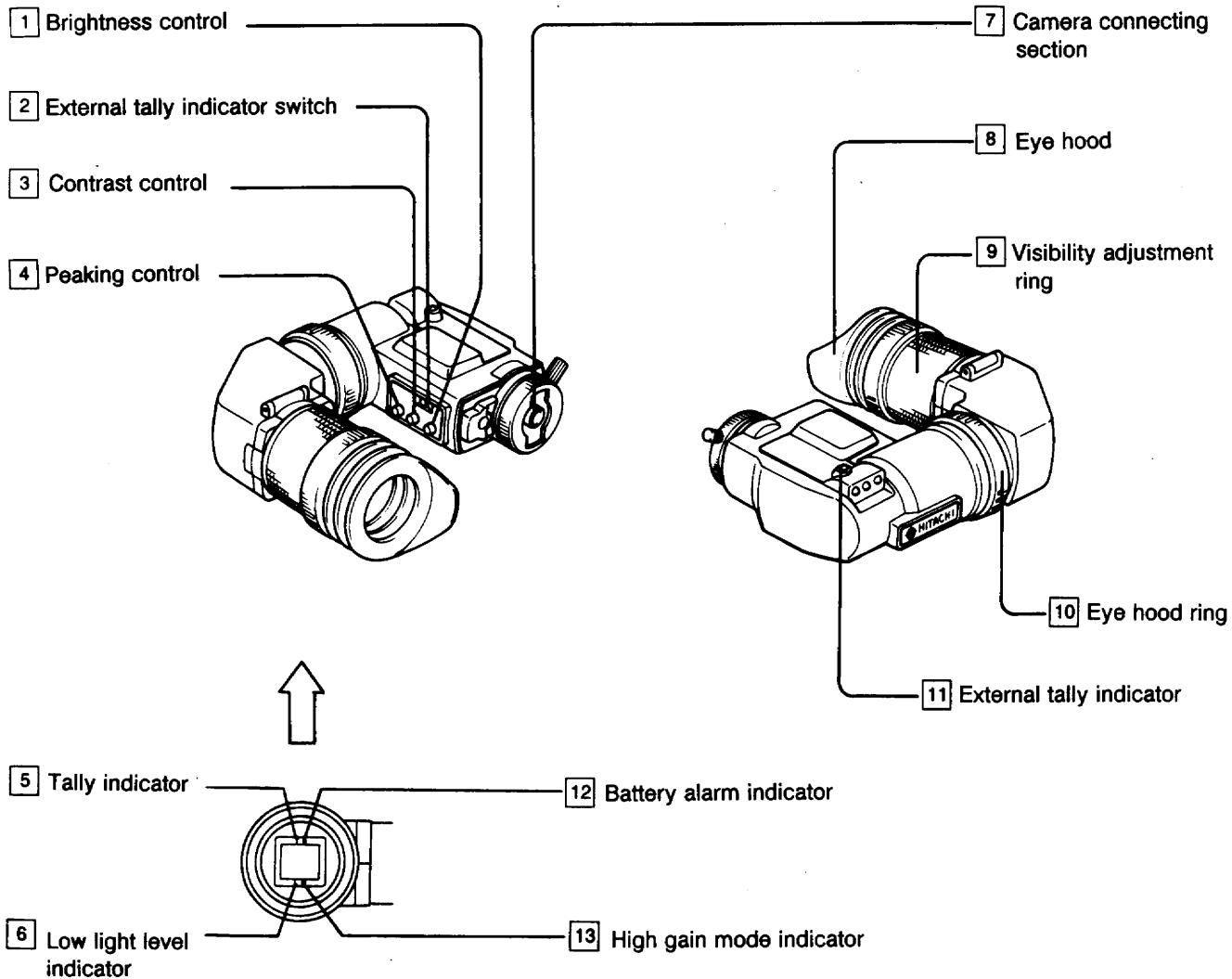

# Name and function of each section

## 1 **Brightness control [BRIGHT]**

Adjust for appropriate bright viewfinder screen.

This adjustment does not affect the output signal of the camera.

## 2 **External tally indicator switch**

ON: The external tally indicator is lit.

OFF: The external tally indicator goes off.

## 3 **Contrast control**

Adjust for appropriate contrast on the viewfinder screen.

This adjustment does not affect the output signal of the camera.

## 4 **Peaking control**

Adjust for a sharp picture. This adjustment does not affect the output signal of the camera.

## 5 **Tally Indicator [T]**

This lamp lights

(1) When the connected VTR is recording, or

(2) When the remote operation unit RU-Z1 is connected and its TALLY switch is pressed.

## 6 **Low light level Indicator [L]**

When the L lamp is lit, it indicates that the scene illumination is insufficient. Set the gain switch to M or H, or increase illumination.

**Note:** When this indicator is lit, auto white balance is invalid.

## 7 **Camera connecting section**

Connect this section to the viewfinder connector of the camera head (refer to page 17.)

## 8 **Eye hood (eyepiece section)**

## 9 **Visibility adjustment ring**

Adjust for appropriate visibility (refer to page 19.)

## 10 **Eye hood ring**

Loosen this ring to adjust the direction (tilt) of the eye hood.

## 11 **External tally Indicator**

When the external tally indicator switch **2** is on, this indicator and the tally indicator **5** light.

## 12 **Battery alarm Indicator [B]**

When the battery voltage of the camera or a VTR is lowered, the "B" lamp is lit. Charge the battery immediately.

## 13 **High gain mode Indicator [H]**

When the "H" lamp is not lit, it indicates that the gain switch of the camera is set to L.

When the "H" lamp is lit, it indicates that the gain switch of the camera is set to M or H.

# Name and function of each section

## Zoom lens (Example: 16X zoom lens A16×9BRM-27)

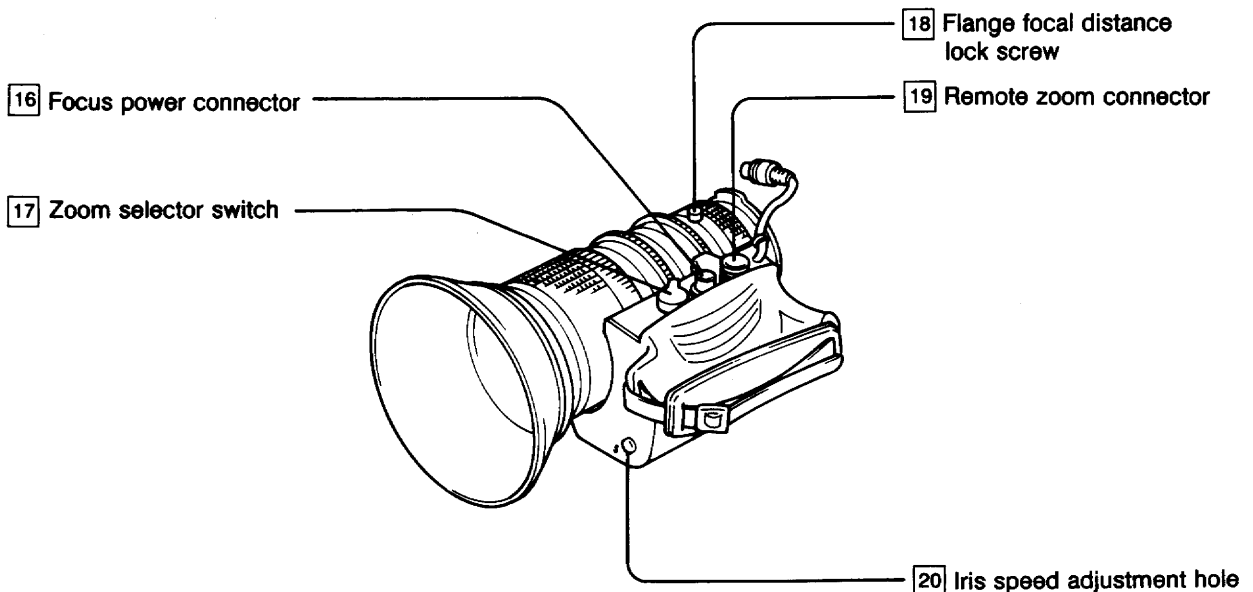
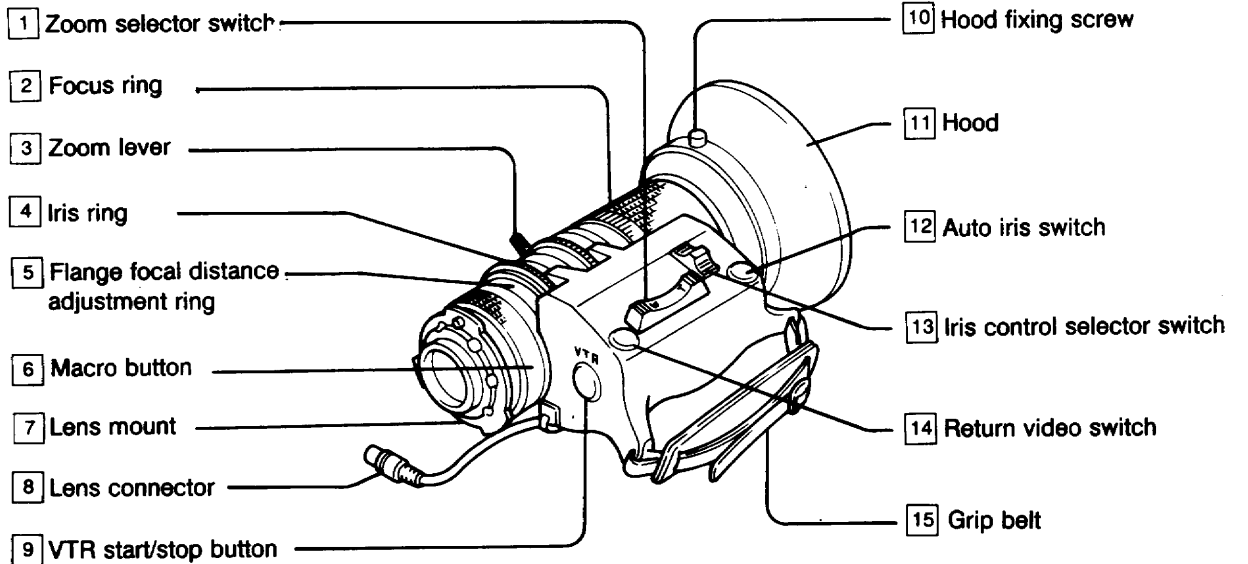

# Name and function of each section

## 1 Zoom selector switch [T-W]

Press the T or W side of this switch appropriately.

T: Telephoto side

W: Wide angle side

The zooming speed varies according to pressing force.

## 2 Focus ring

Adjust this ring for optimum focus.

## 3 Zoom lever

Use this lever to perform zoom operation.

## 4 Iris ring

Adjust the lens iris.

## 5 Flange focal distance adjustment ring

Loosen the lock screw **18** and turn this ring to adjust the flange focal distance (refer to page 36 .)

## 6 Macro button

In case of close-up, set the zoom lever to MACRO while pressing this button.

## 7 Lens mount

## 8 Lens connector

Connect this connector to the lens connector of the camera.

## 9 VTR start/stop button [VTR]

This button performs the same function as the VTR start/stop button **7** of the camera head. (page 6.)

## 10 Hood fixing screw

## 11 Hood

## 12 Auto Iris switch

When the camera is being used in the manual iris mode, the lens iris is automatically controlled only while this switch is being pressed.

## 13 Iris control selector switch [A-M]

A: The lens iris is controlled automatically by the signal converted from the video signal of the camera.

M: The lens iris can be controlled manually by rotating the iris ring.

## 14 Return video switch [RET]

When a VTR is connected to the camera, the picture reproduced by the VTR is displayed on the viewfinder while this switch is pressed. When the RU-Z1 is connected to the camera, the signal from AUX VIDEO is displayed on the viewfinder while this switch is pressed.

## 15 Grip belt

## 16 Focus power connector

Connect the optional focus servo module FSM-30B.

## 17 Zoom control selector switch [ZOOM SERVO-MANUAL]

SERVO: Motorized zoom operation

MANU: Manual operation by the zoom lever

## 18 Flange focal distance lock screw

## 19 Remote zoom connector

Connect the optional servo zoom control unit to this connector.

## 20 Iris speed adjustment hole

Adjust the variable resistor in the hole when hunting occurs in the auto iris mode (page 36.)

### Installation of filter

A filter ( $\phi 77$  P = 0.75) on the market can be installed on this zoom lens.

**Note:** In this manual, the 16X zoom lens (A16X 9BRM-27) is described as an example of a lens. For other lenses, refer to the operation manual supplied with the lens.



# How to assemble camera

## How to mount lens

1. Rotate the mount ring fully counterclockwise (in the direction of arrow).

2. Fit the pin of the lens to the recessed portion of the camera mount, then insert the lens into the lens mount. (Before doing this, remove the protective caps of the camera and the lens mount.)

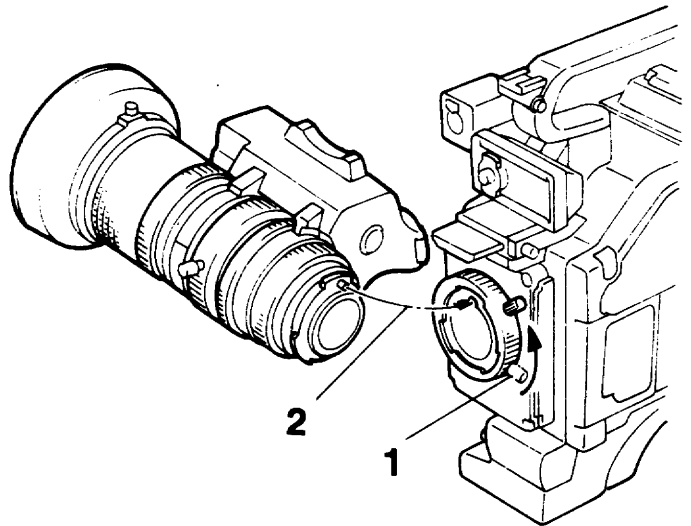

3. Secure the mount clamp in the direction of arrow.

4. Connect the connector of the lens cable to the LENS connector of the camera.

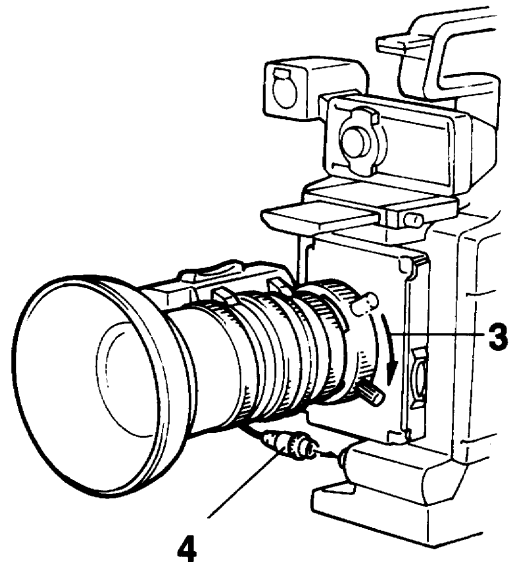

**Caution:** Since power is still supplied to the LENS connector even when the camera is turned off, turn off the power source when connecting or disconnecting the lens cable.

# How to assemble camera

## How to install 1.5-inch viewfinder

1. Turn the lock lever of the camera in the direction of arrow and fix the VF guide.

2. Turn the lock lever of the viewfinder fully counterclockwise (in the direction of arrow).

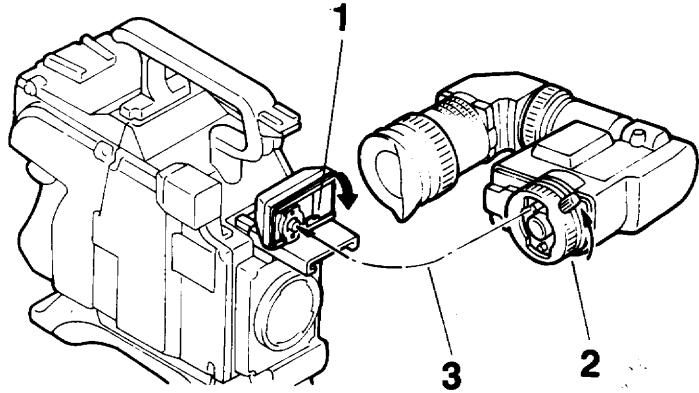

3. Fit the two guide pins of the viewfinder to the respective guide holes of the camera, then insert the viewfinder.

4. Secure the lock lever of the viewfinder in the direction of arrow.

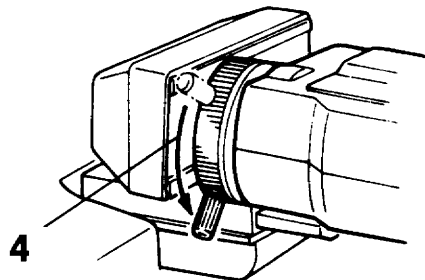

**Caution:** Turn off the power switch before installing or removing the viewfinder.

# How to assemble camera

## How to set viewfinder for the best viewing angle

The viewfinder can be set to the best viewing angle.  
The eyepiece can be turned up by 90°.

### Position adjustment

1. Turn the lock lever in the direction of arrow to loosen the lock.
2. Turn the lock screw in the direction of arrow to loosen the lock.
3. Move the viewfinder to the easy-to-view position.
4. Secure the lock screw in the opposite direction of arrow.
5. Turn the lock lever in the opposite direction of arrow, then fix the viewfinder.

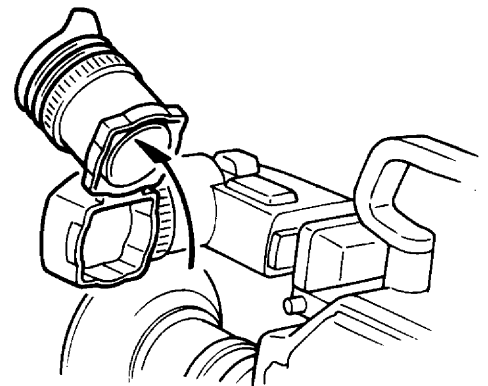
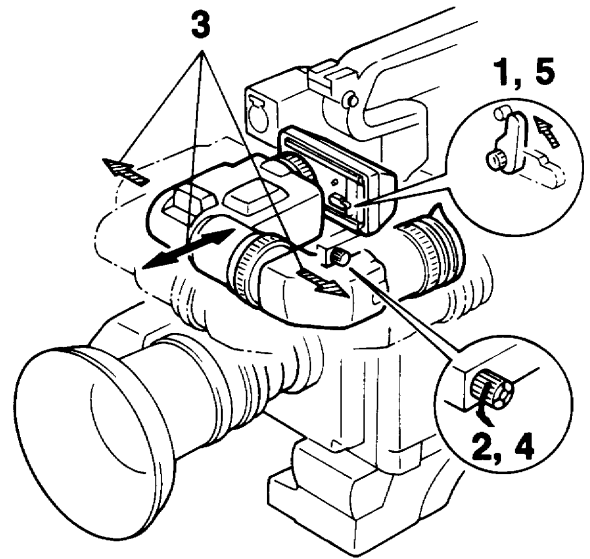

### Eye hood

The eye hood can be turned up in the direction of arrow.

The viewfinder screen can be seen without using the eye hood.

In addition, the viewfinder can be turned upright for the convenience of transportation.

# How to assemble camera

## Angle adjustment of eyepiece

1. Rotate the eye hood ring in the direction of arrow.
2. Adjust the angle of the eyepiece vertically for the best viewing position.  
Upper: Approx.  $120^\circ$  to the horizontal  
Lower: Approx.  $90^\circ$  to the horizontal
3. Rotate the eye hood ring in the opposite direction of arrow to secure the ring.

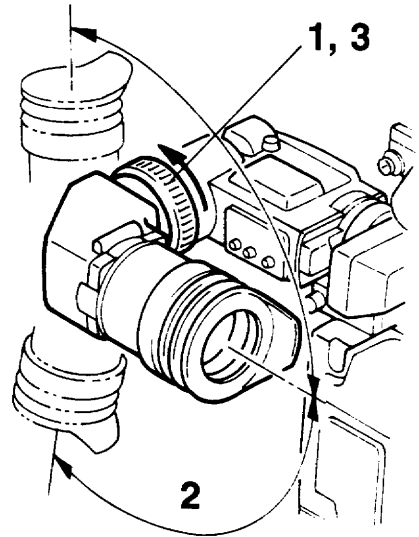

## Adjustment of visibility

Adjust the visibility after completion of focus adjustment.

1. Rotate the visibility adjustment ring so that the picture on the viewfinder becomes clear.

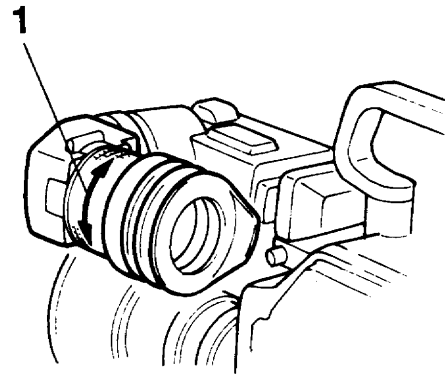

**Note:** The correctable range of visibility is from 0.5D to - 3D.

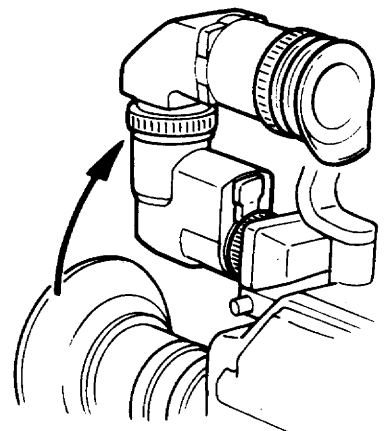

**Warning:** Never see the sun or a strong light source through the eyepiece to avoid a burn or loss of eyesight. Do not leave the camera with the eyepiece facing the sun. Otherwise, sunlight through the eyepiece may be focused inside the viewfinder to cause burning inside the viewfinder.

# How to assemble camera

## How to install camera adaptor

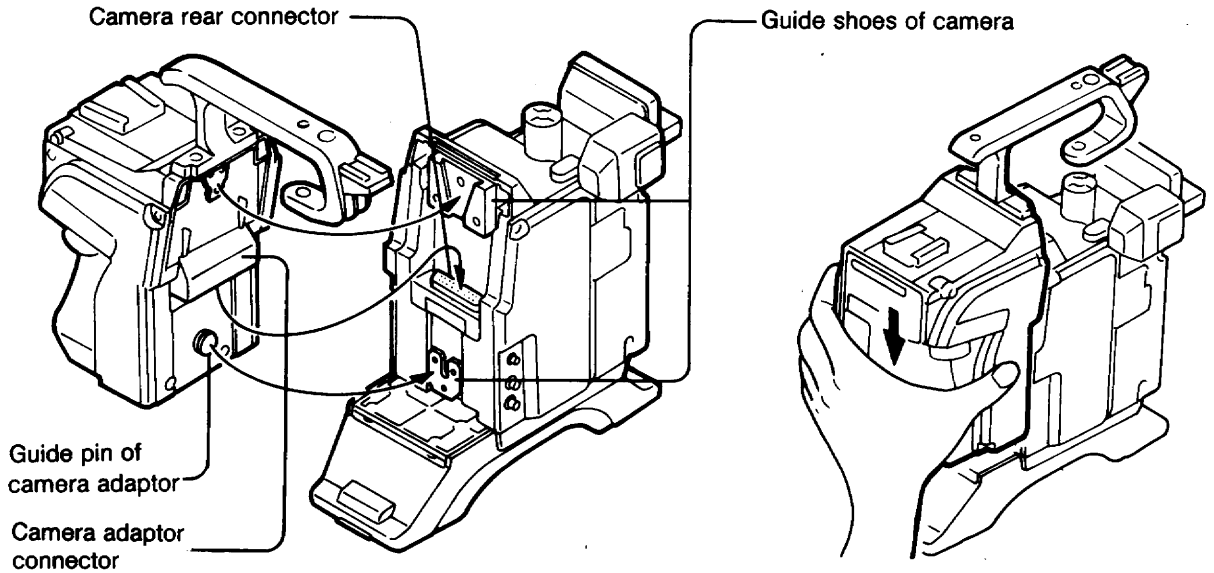

- 1 Fit the guide shoes at the camera side to the respective guide pins at the camera adaptor side, then hold down the camera adaptor to allow both connectors to be mated.

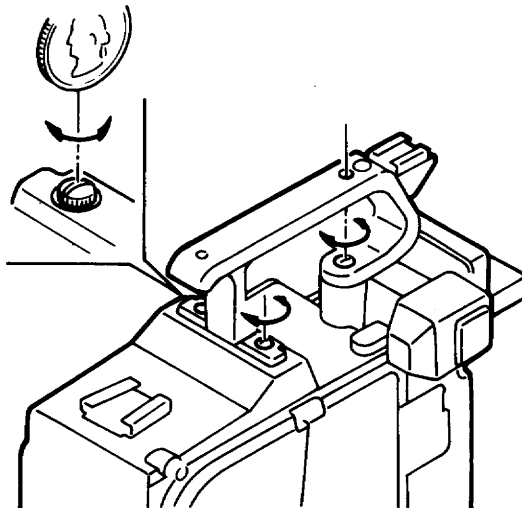

- 2 Secure the screws associated with the handle with a coin to fix the camera adaptor to the camera.

# How to assemble camera

## How to install mic

### How to install optional MC-C2 mic

1. Push the mic into the mic connector of the camera head until a click sounds.
2. To remove the mic, pull out the mic while pressing the lock button.

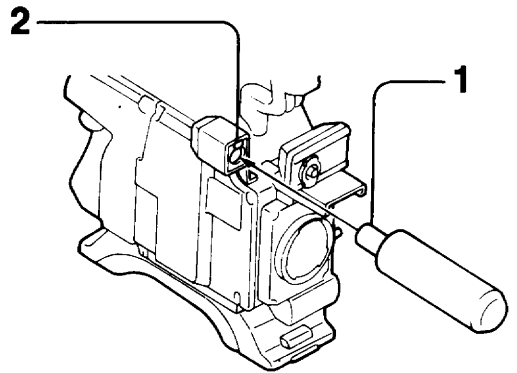

### How to install the recommended Sennheiser ME-66 microphone

When installing the mic ME-66, prepare the optional mic holder MH-C1A and the mic cable C-240MA.

1. Install the mic holder MH-C1A on the side panel of the camera head.
2. Insert the mic into the sleeve supplied with the mic holder, and connect the mic cable connector to the mic.
3. Open the mic holder and put the mic in it.
4. Connect the mic cable connector to the mic connector of the camera head.

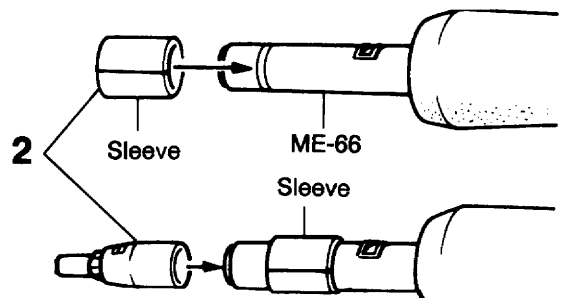
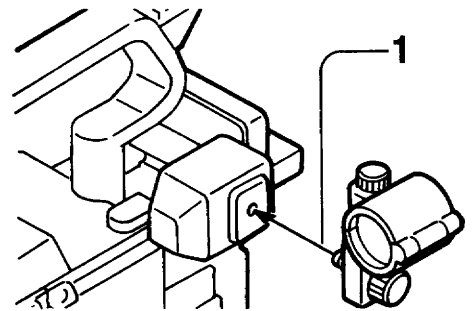

### Connection of earphone

Sound can be monitored by connecting an earphone (8 to 10 ohms) on the market to the audio monitor jack (AUD. MON.) of the camera. When the remote operation unit RU-Z1 is connected, sound cannot be monitored.

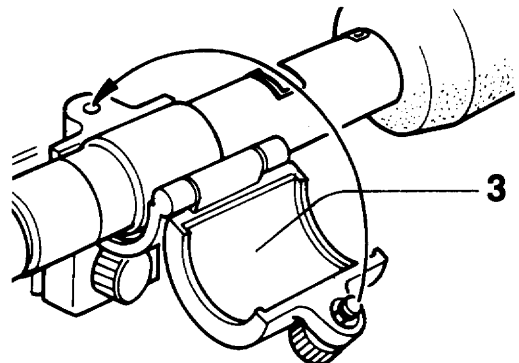

# How to assemble camera

## Power supplying to a mic

The method of supplying power from the camera to a mic vary with the type of the mic used. Set it as follows.

### DC power supply

(MIC DC)

| +9V   | OFF  | PHANTOM             |
|-------|--|---------------------|
| MC-C2 | Condenser mic with battery<br>or dynamic mic | ME-66<br>(See Note) |

Note: A battery is not required.

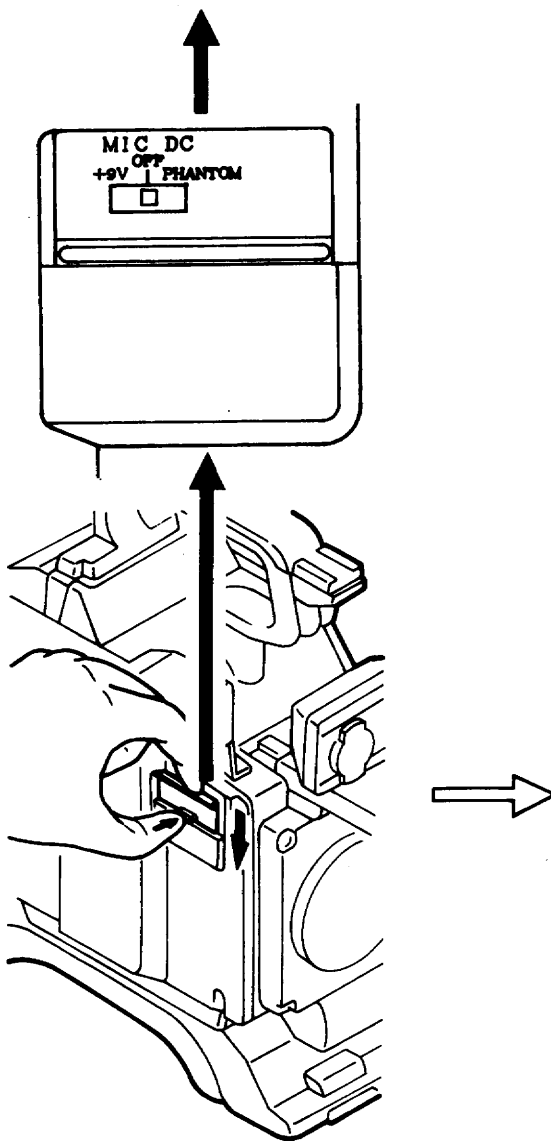

# How to assemble camera

## How to install optional battery pack DP-15B

When operating the camera with a battery, use the optional battery pack DP-15B and the battery adaptor BA-15. When a VTR is connected to the camera, DC power is supplied from the VTR to the camera.

1. Install the battery adaptor BA-15 on the rear of the camera adaptor, using four screws.
2. Fit the three guide holes of the battery pack to the guide pins of the battery adaptor, then press down the battery pack.
3. Connect the battery connector to the DC-IN of the camera.
4. Set the POWER SELECT switch of the camera adaptor to EXT/BATT2.

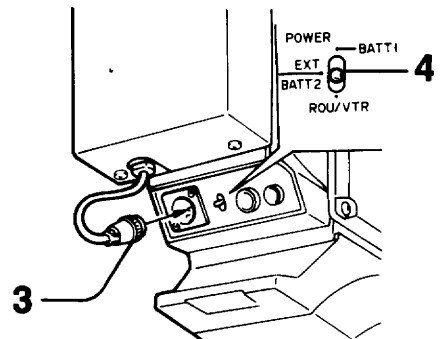
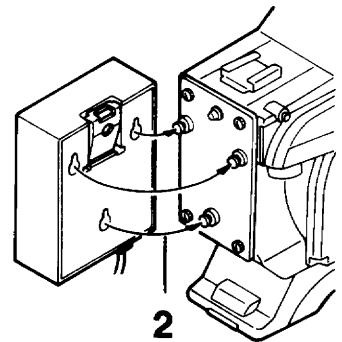
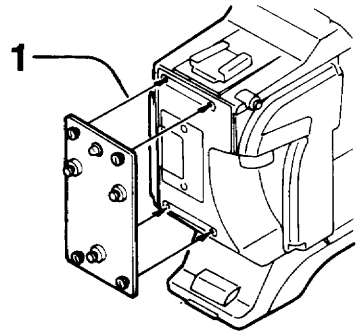

To remove the battery pack, lift the battery pack while pressing the lock lever of the battery pack in the direction of arrow.

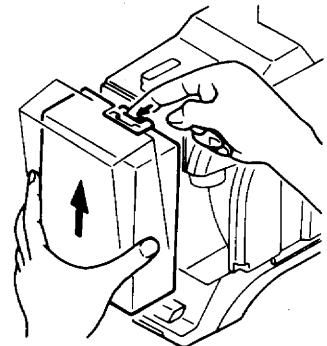

### CAUTION:

When installing or removing the battery pack, set the POWER SELECT switch to a position other than EXT.



# How to assemble camera

## How to install BETACAM VTR (BVV-1 or BVV-5)

1. Loosen three screws with a coin, and remove the camera adaptor and the handle together.

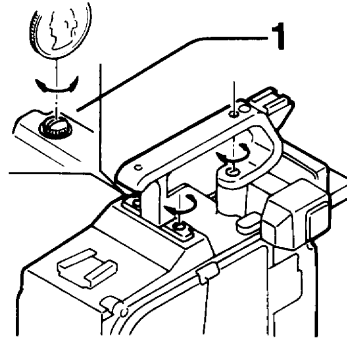

2. Install the handle supplied with a VTR.

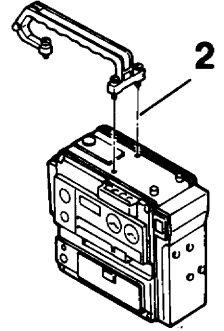

3. Fix the guide pins at the camera side to the respective guide pins at the VTR side, then hold down the VTR to allow both connectors to be engaged.

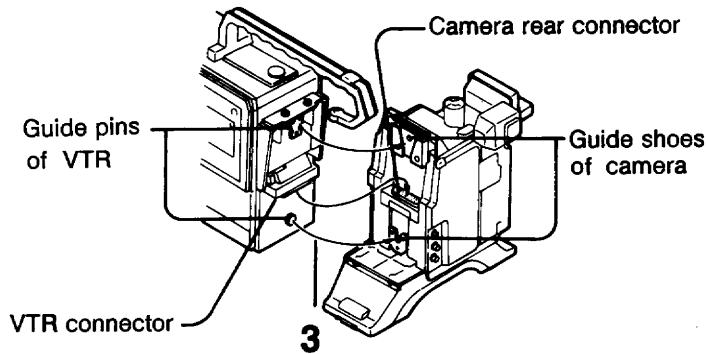

4. Secure the screws associated with the VTR handle and the fixing screws to fix the VTR to the camera.

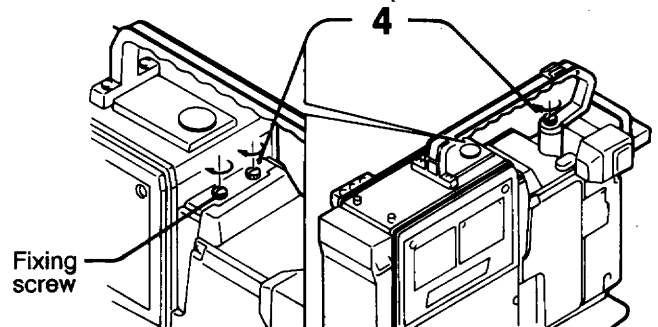

## How to remove VTR

Reverse the above order of procedure.

## Storage in carrying case

To store the camera docked with the Batacam\* VTR (BVV-5), remove the power supply box and the spacer.

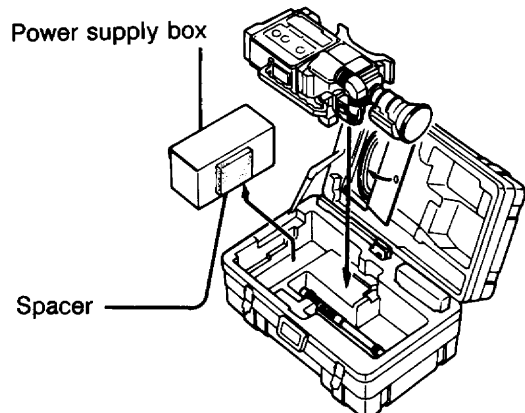

# How to assemble camera

## Shoulder pad

When the camera is docked with a VTR, the center of gravity changes according to the used VTR. Move the shoulder pad backward (25mm or 45mm), if necessary.

1. Remove four screws fixing the shoulder pad to the camera.

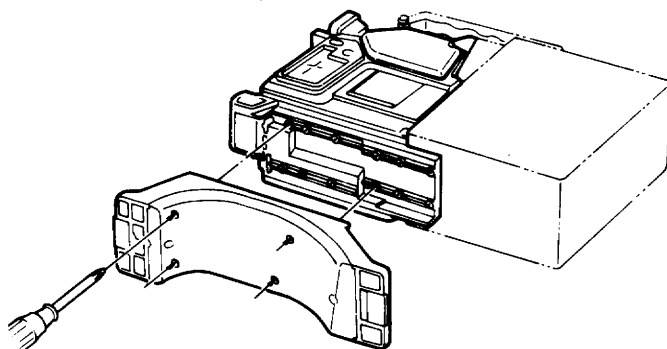

2. Move the shoulder pad appropriately and fix it with four screws.

Screws will be easily fixed by aligning the line marked on the shoulder pad frame with the rear of the camera.

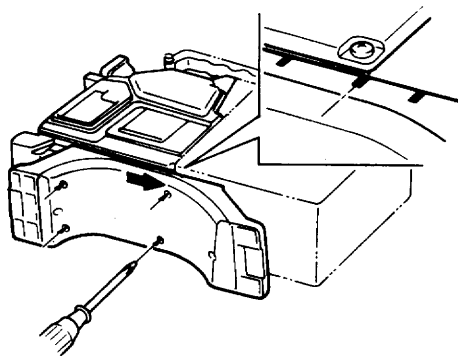

**Note 1.** Do not use screws other than supplied (M4, 12mm long).

**Note 2.** When the camera adaptor is used, move the shoulder pad to the original position.

**Note 3.** When a M-II VTR is used, move the shoulder pad by 25mm.

# How to assemble camera

## How to install camera on tripod

Install the camera on a tripod using the supplied tripod adaptor TA-Z1.

1. Install the tripod adaptor on the tripod securely.
  - Move the screw of the tripod adaptor to the position where adequate balance is obtained, then install the tripod adaptor.
  - Since two tapped holes are provided in the tripod adaptor, use a tapped hole matching the tripod adaptor.

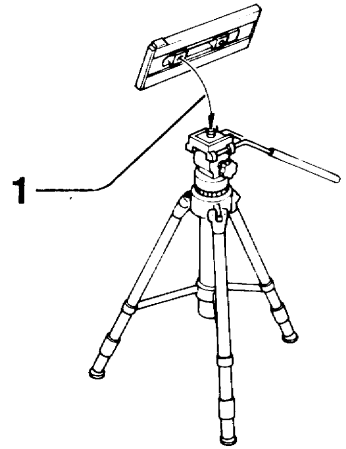

2. Install the camera on the tripod adaptor.
  - Fit the hook on the camera side to the hook on the tripod adaptor securely, then turn the lock lever in the direction of arrow until a click sounds.

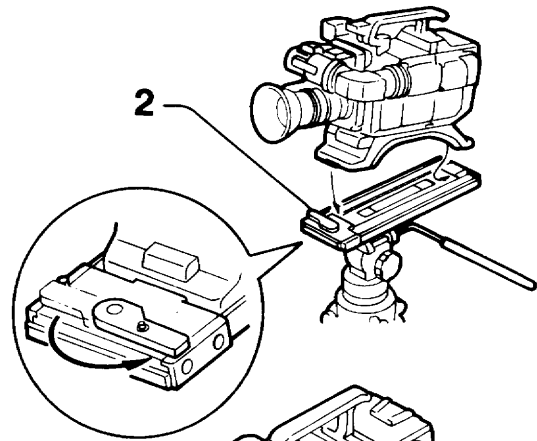

3. Loosen the screw of the tripod slightly, then move the tripod adaptor for better balance, and secure the screw.

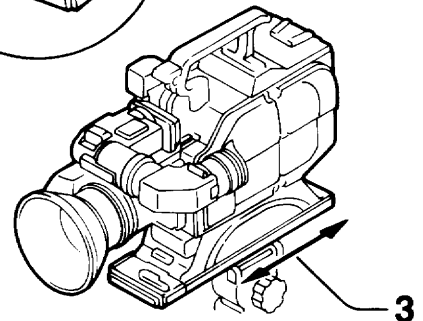

## How to remove the camera from the tripod adaptor.

Turn the lock lever in the direction of arrow while pressing the red lock pin.

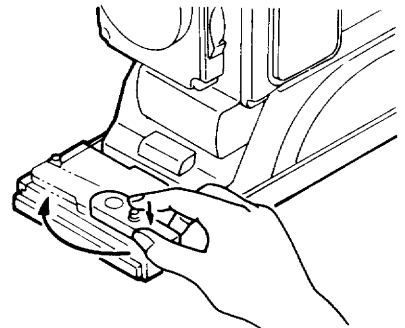

### Caution:

1. The camera provided with a zoom lens weighs approx-5kg. When a VTR is docked to the camera, the weight will exceed 10kg. Use a large size tripod suitable for the camera weighing at least 10kg. Such a large size tripod will provide stable operation of the camera.
2. Do not use a tapped hole near the hook for the tripod adaptor on the camera to install a tripod. If the camera is installed by using the hole, the camera may drop.

# Connection to VTR

## Dockable VTRs

### Example of VTRs

Matsushita Electric Industrial Co., Ltd.(PANASONIC)  
AG-7450(S-VHS), AU-400/410 (M II), AU-45H(M II Promind)

Victor Company of Japan, Ltd.(JVC)  
BR-S410/S411/S420/S422 (S-VHS)

Sony Corp. (SONY)  
EVV-9000 (Hi8), PVV-1 (Betacam SP 2000 PRO)  
BVV-1, BVV-5(Betacam)

### How to Install VTR

#### ● BVV-1 and BVV-5

These VTR's are directly dockable to the camera.  
For details, refer to page 24.

#### ● AU-400/410

Install this VTR, using the optional VTR adaptor CA-Z1M.  
For details, refer to the operation manuals of the VTR and the VTR adaptor.

#### ● AG-7450 VTR

Install this VTR, using the optional VTR adaptor CA-Z1SP.  
For details, refer to the operation manuals of the VTR and the VTR adaptor.

#### ● BR-S410/S411/S420/S422 VTR

Install this VTR, using the optional VTR adaptor CA-Z1SJ.  
For details, refer to the operation manuals of the VTR and the VTR adaptor.

#### ● PVV-1/EVV-9000

Install this VTR, using the optional VTR adaptor CA-Z1HB.  
For details, refer to the operation manuals of the VTR and the VTR adaptor.

#### ● AU-45H

Install this VTR, using the optional VTR adaptor CA-Z1M2.  
For details, refer to the operation manual of the VTR and the VTR adaptor.

### Power save

When setting the power switch (VTR/CAM) of the camera head to VTR SAVE, each VTR operates as follows.

**Note:** The model names and the specifications of the VTRs are subject to change.

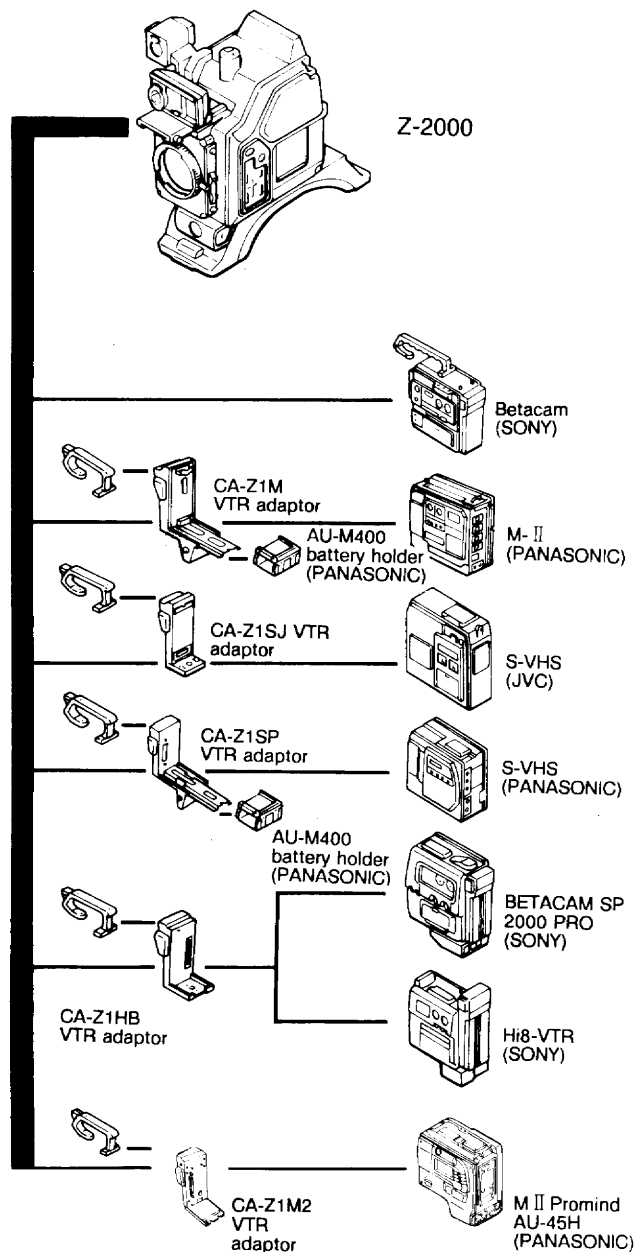

# Connection to VTR

| VTR                | Operation  |
|--------------------|--|
| EVV-9000           | Since the Hi8 VTR is not provided with the power save function, the VTR remains in the standby mode. |
| AG-7450            | The VTR is placed in the power save mode, and the battery power is saved.                            |
| BR-S410<br>BR-S411 | All the operations of the VTR become unavailable.  |

## REC VIEW function and playback monitor

When a VTR (Hi8 VTR, etc.) provided with the REC VIEW function is in the REC PAUSE mode, and the REC button on the lens is pressed, the picture recorded last appears on the viewfinder for several seconds. Further, when the VTR is placed in the playback mode, the playback picture appears automatically on the viewfinder and the sound can be monitored by the headset.

When a VTR not provided with the REC VIEW function is placed in the playback mode, the playback picture can be monitored while the RET button is being pressed. The above description may not be applied to some type of VTRs.

| Format  | VIDEO NO.<br>(Note1) | MIC LEVEL<br>(Note1) | VTR Cable          | VTR Adaptor | VTR  |                        |
|---------|----------------------|----------------------|--------------------|-------------|--|------------------------|
|         |                      |                      |                    |             | Type   | Mfr.                   |
| BETACAM | 1                    | -60dB                | -----              | -----       | BVW-1<br>BVW-5   | Sony                   |
|         |                      |                      | -----              | CA-Z1HB     | PVW-1  |                        |
|         |                      |                      | C-201TE<br>C-501TE | -----       | BVW-25<br>BVW-35<br>BVW-50                                     |                        |
| M II    | 1                    | -60dB                | -----              | CA-Z1M      | AU-400<br>AU-410   | } Note 2<br>Matsushita |
|         |                      |                      | -----              | CA-Z1M2     | AU-45H   |                        |
|         |                      |                      | C-201TE<br>C-501TE | -----       | AU-500   |                        |
| S-VHS   | 2                    | -20dB                | C-201TD<br>C-501TD | -----       | VL-S100  | Hitachi                |
|         |                      |                      |                    |             | AG-7400  | Matsushita             |
|         | 3                    | -60dB                | -----              | CA-Z1SJ     | BR-S410<br>BR-S411<br>BR-S420<br>BR-S422                       | JVC                    |
|         |                      |                      |                    |             | CA-Z1SP  |                        |
| Hi 8    | 2                    | -60dB                | -----              | CA-Z1HB     | EVV-9000   | Sony                   |
| U-matic | 4                    | -60dB                | C-201TD<br>C-501TD | -----       | BVU-50<br>BVU-110<br>BVU-500H<br>BVU-150<br>VO-4800<br>VO-6800 | Sony                   |
|         |                      | -20dB                |                    |             | CR-4700  |                        |

**Note 1:** Set on FUNCTION menu (See page 43).

**Note 2:** Color difference signal level setting by SW102. Set to M II when an M II VTR is connected with a VTR cable.

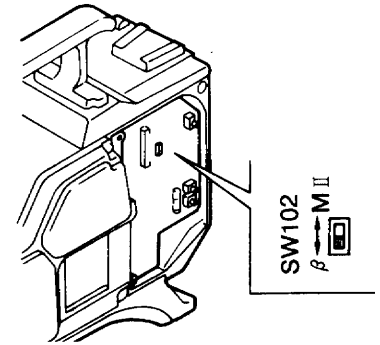

# Power supply

When the camera adaptor CA-Z1A is installed, power can be supplied to the camera as shown below. Set the POWER SELECT switch in accordance with the type of power supply.

1. When the optional AC adaptor AP-60B is connected to the DC IN terminal, set the POWER SELECT switch to EXT/BATT2.
  2. When the connector of the optional battery pack DP-15B is connected to the DC IN terminal, set the POWER SELECT switch to EXT/BATT2.
  3. When the remote operation unit ROU or a VTR is connected to the 28-pin connector, set the POWER SELECT switch to ROU/VTR.
  4. When the battery made by Anton Bauer is connected to the BATT 12V IN terminal through the battery adaptor, set the POWER SELECT switch to BATT1.
- When a VTR like a Betacam VTR is docked to the camera, power is supplied from the VTR.
  - When using the battery pack DP-15B, the camera can be operated for approx. 120 minutes. To charge the battery, use the battery charger AP-61B.

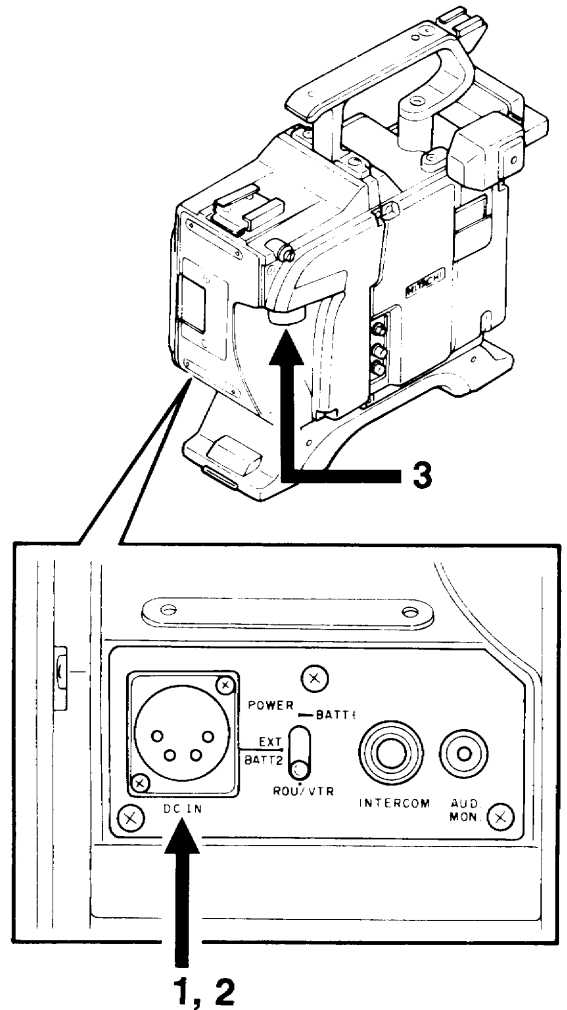

## POWER SELECT switch setting

| Power supply | Setting position |
|--------------|------------------|
| 1            | EXT /BATT2       |
| 2            | EXT/BATT2        |
| 3            | ROU/VTR          |

### Note:

1. Though this camera is operated by supplying 10.5 to 17V to the DC IN terminal, use the rated 12 to 13V DC. If voltage of 17V DC is applied, the camera may be damaged.
2. When using the battery made by Anton Bauer, the adaptor is necessary. For details, contact your nearest Hitachi Denshi sales representative.

### Battery alarm indicator

When voltage is insufficient, the battery alarm indicator "B" is lit.

# Basic shooting procedure

1. Connect the camera to a VTR, then connect it to a monitor.

Set the switches of the VTR according to the operation manual of the VTR.

2. Set switches of the camera.

3. Set the iris control selector switch of the lens to A.

4. Set the color temperature filter disk selector to 1 (in the case of indoor tungsten illumination).

5. Turn on the POWER switches of the monitor and the VTR.

6. Turn on the POWER switch of the camera.

7. Remove the lens cap.

8. Press the AUTO BLACK switch.

9. Press the AUTO WHITE switch (at this point, shoot a white object).

10. Shoot an object.

11. Focus the camera and operate zooming.

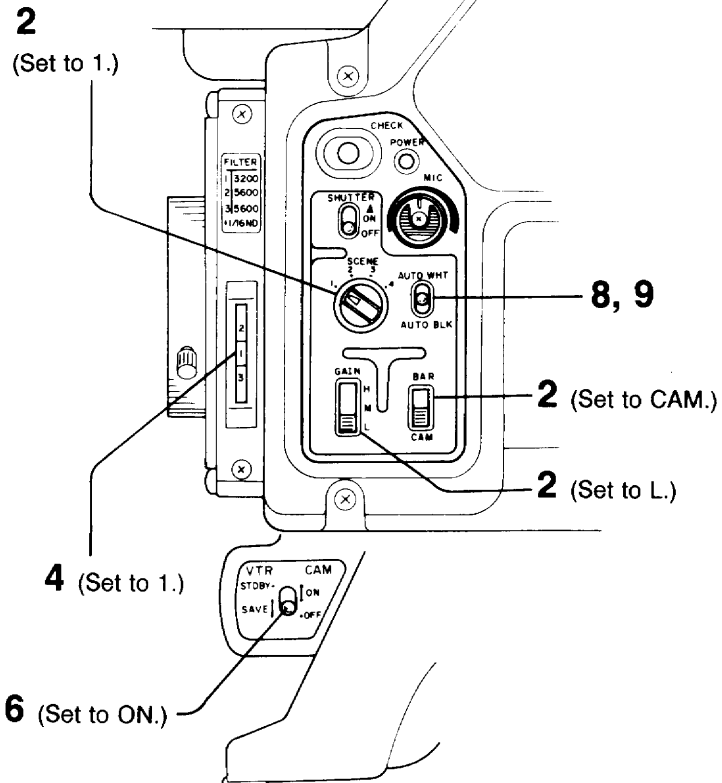
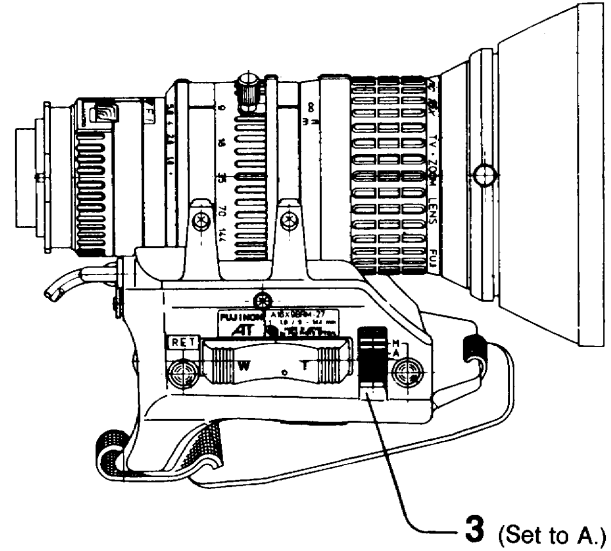

# Adjustment and operation

## Adjustment of color monitor

Adjust the color monitor, using the color bar signal (SMPTE standard for NTSC) fed from the camera.

1. Set the BAR/CAM switch to BAR.
2. Set the color monitor to the B (BLUE) MODE.
3. Adjust the chroma control of the monitor as shown below.

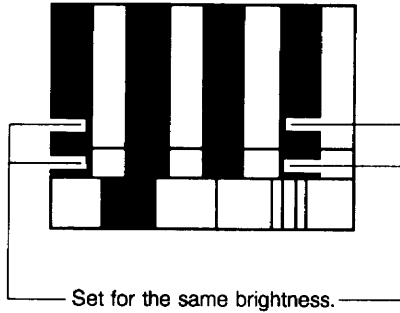

4. Adjust the hue control of the color monitor as shown at right.
5. Return the mode of the color monitor to the normal three-colors mode.

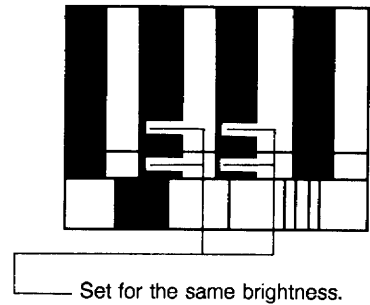

Repeat steps 3 and 4 until the brightness of the four blue bars is the same.

6. Adjust the brightness control of the color monitor
7. Set the BAR/CAM switch to CAM.

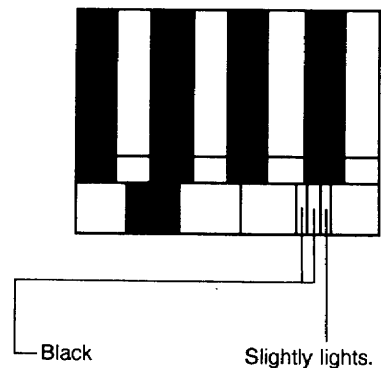



# Adjustment and operation

## Iris control

Three lens iris control methods are available.

### 1. Auto mode

Set the iris control selector switch on the zoom lens to A.

Then, an appropriate lens iris is automatically established by the signal converted from the video signal.

### 2. Manual mode

Set the iris control selector switch to M. Then, the lens iris can be adjusted by rotating the iris ring.

### 3. Instantaneous auto iris mode

Set the iris control selector switch to M and press the auto iris switch. Then the lens iris can be automatically adjusted only while the auto iris switch is pressed.

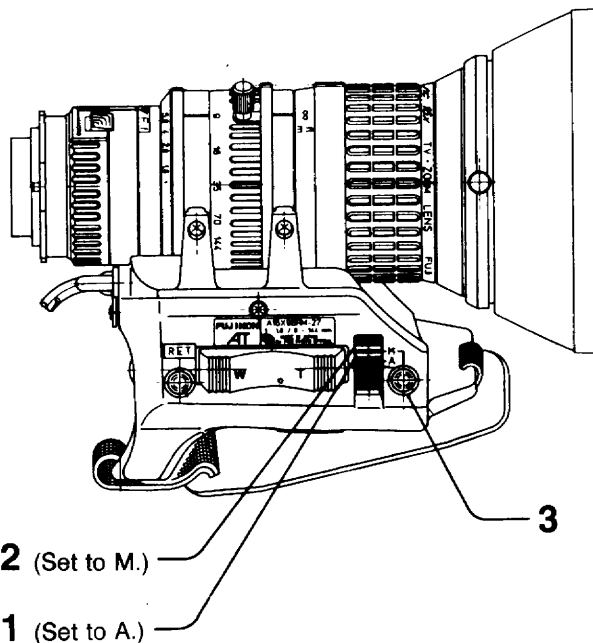

**Note 1.** For AUTO IRIS PEAK/AVERAGE setting, see page 42.

**Note 2.** For fine AUTO IRIS control, see page 49.

### Zebra pattern

When setting the ZEBRA ON/OFF switch to ON, a zebra pattern will appear in the image portion where video level exceeds 90%.

This is used as a reference when adjusting the video level manually.

### Instantaneous auto iris mode

This is convenient to obtain an appropriate lens iris instantaneously when shooting scenes against light in the manual mode.

# Adjustment and operation

## Zoom lens [Example: A16X9BRM-27]

### 1. Motorized zooming control

Set the zoom control selector switch to (SERVO) and press the zoom switch. Pressing **W** provides a wide angle. Pressing **T** provides a telephoto. When pressing the switch harder, a zooming speed will be faster. When pressing the switch lightly, a zooming speed will be slow.

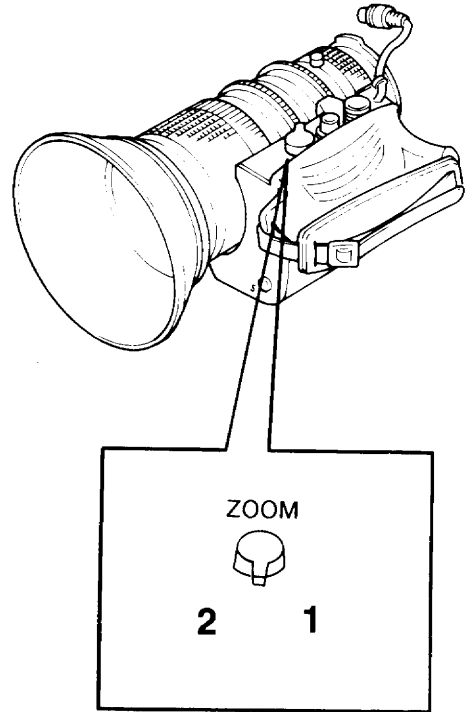

### 2. Manual zoom

Set the zoom control selector switch to **M** (MANUAL). Zooming can be controlled by the zoom lever.

### Focusing

When focusing is achieved at the telephoto side, focusing is achieved at the wide angle side.

### Servo zoom control unit

By using the optional servo zoom control unit, zooming can be controlled at the grip section of the tripod. For details, contact your nearest Hitachi Denshi sales representative.

# Adjustment and operation

## Close-up (macro)

Use this function when shooting an object at a short distance of 1.1m or less.

1. Bring the lens close to the object until the desired size of a picture is displayed.
2. Set the focus ring to  $\infty$ .
3. Set the zoom control selector switch to MANU.
4. Rotate the MACRO ring and achieve focus.

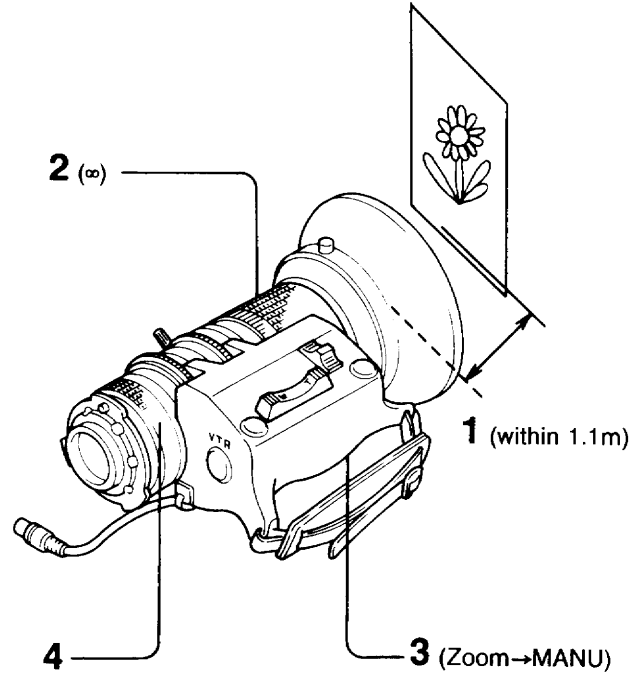

**Note:** When the focus ring is set to a position other than  $\infty$ , the edge of the screen may be dark.

# Adjustment and operation

## Selection of optical filter

Select an optical filter in accordance with the light source to obtain proper color balance.

| Display | Color temperature, ND | Light source  |
|---------|-----------------------|---|
| 1       | 3200K                 | Inside studio (under tungsten or halogen illumination)<br>At sunrise or sunset. |
| 2       | 5600K                 | Under fluorescent lamp illumination. Outdoors on a cloudy or rainy day.         |
| 3       | 5600K + 1/16ND        | Outdoors on a fine day  |

### ND filter

An ND filter reduces only light quantity without changing color.

## Selection of video gain

When a picture with proper brightness cannot be obtained because of insufficient illumination, increase sensitivity by using the gain switch.

1. When light quantity is insufficient, the indicator L inside the viewfinder lights.

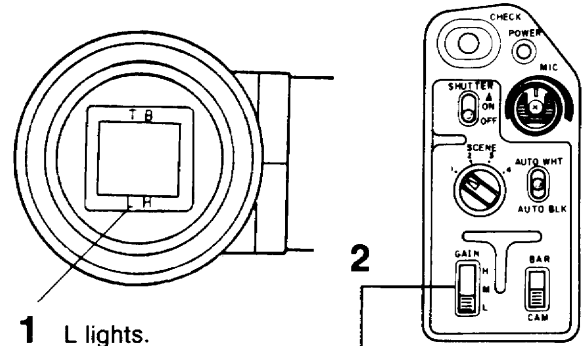

1 L lights.

- L: Standard gain (normal position): 0dB
- M: Video gain is increased by 9dB (approx. three times):  $\pm 3$ dB
- H: Video gain is increased by 18dB (approx. eight times):  $\pm 6$ dB

### ULTRA GAIN

When the ULTRA GAIN ON/OFF switch 12 (page 8.) is set to ON when the video gain is more than 12dB, the sensitivity is further increased by approximately 12dB. In this case, the horizontal resolution is lowered by approximately 50%. Normally set this switch to OFF.

### Note:

1. Since noise increases in the high gain mode (M or H), set the video gain to the normal mode (0dB) under sufficient illumination.
2. When the indicator L lights, auto white balance in the MEMORY mode is not available.

# Adjustment and operation

## Adjustment of flange focal distance

When focus is not achieved at the telephoto side or the wide angle side, adjust the flange focal distance of the lens.

1. Set the iris control selector switch of the zoom lens to M.
2. Set the lens iris fully open (f1.4).
3. Place an object 2 to 2.5m away, then illuminate the object so that the proper video level can be obtained at f1.4.
4. Loosen the flange focal distance adjustment fixing screw of the lens.
5. Set the zoom control selector switch to MANU and set the zoom lever to T(telephoto), then achieve focus by rotating the focus ring.
6. Set the zoom lever to W(wide angle) and achieve focus by rotating the flange focal distance adjustment ring.
7. Repeat steps 5 and 6 until focus is achieved at both T and W.
8. Secure the lens flange focal distance adjustment fixing screw.

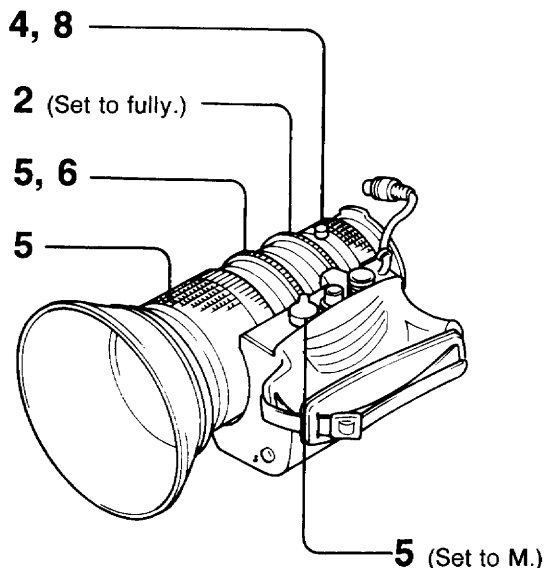

### Flange focal distance adjustment

This is to adjust the distance between the lens mounting surface and the CCD imaging surface. If the distance is not appropriate, the focus will not be achieved either at the telephoto side or the wide angle side.

### Adjustment when the lens is changed

When a zoom lens is replaced, the following adjustment is needed.

- (1) Flange focal distance adjustment
- (2) Auto iris speed adjustment

Using the gain (or iris speed) control on the lens, maximize the gain (or speed) within the range where no hunting occurs.

# Adjustment and operation

## Adjustment of black balance

Adjust black balance to obtain a picture with proper tone.

### Adjustment

Press the AUTO BLACK balance, and the lens iris automatically closes.

Then black balance is adjusted and the value is stored in a memory.

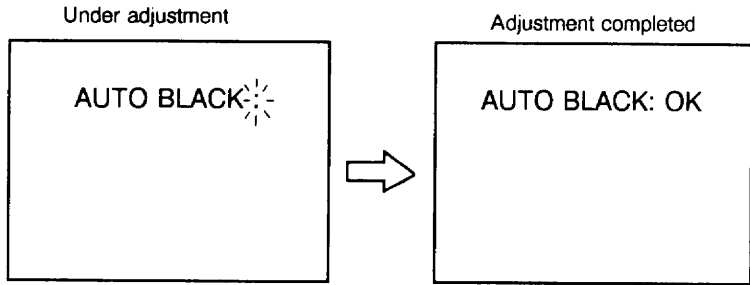

Displayed only for approx. 3 seconds

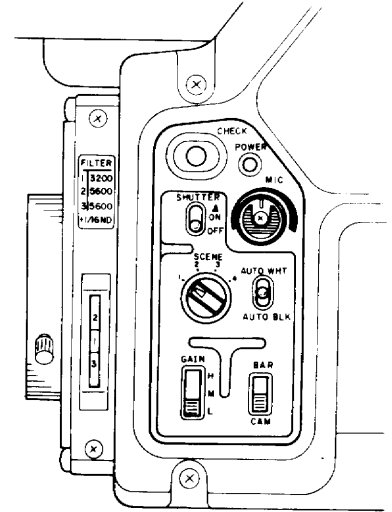

### When black balance is not automatically adjusted

Following messages are displayed on the screen for approx. 6 seconds.

| Display   | Cause   | Remedy   |
|---|---|--|
| AUTO BLACK: -NG-<br>CHANGE TO CAM<br>TRY AGAIN  | The BAR/CAM switch is set to BAR.                                       | Set the switch to CAM, and adjust black balance again.   |
| AUTO BLACK: -NG-<br>IRIS NOT CLOSE<br>TRY AGAIN | The lens iris is not closed.  | Refer to Note 1.   |
| AUTO BLACK:<br>TALLY ON<br>EXECUTE ?            | The tally lamp is lit.  | Set the AUTO WHITE/AUTO BLACK switch to AUTO BLACK while this message is displayed, then the auto black adjustment is performed. |
| AUTO BLACK: -NG-<br>???<br>TRY AGAIN            | Black balance cannot be adjusted because it is out of adjustable range. | Refer to Note 1.   |

### Black balance

- Black balance is not related to illumination conditions.
- The adjustment value is stored in the memory. The stored value is retained after power off unless the black balance is adjusted again.

### Note:

1. The camera or the lens may be out of order. Contact your nearest Hitachi Denshi service representative.
2. The lens automatically closes during adjustment of black balance. In the manual iris control mode, open the lens iris, then start shooting.

# Adjustment and operation

## Adjustment of white balance

White balance adjustment is performed to provide correct and natural white color for a white object under the lighting conditions.

Once white balance is achieved, it is not necessary to adjust the white balance under similar lighting conditions. Before shooting or when the major light source is changed, adjust white balance.

This camera is provided with the following three white balance modes corresponding to the SCENE file.

| White balance mode |   |
|--------------------|---|
| MEMORY             | Adjust white balance each time in accordance with the used light source.                            |
| AUTO               | Appropriate white balance can be obtained at all times in real time.<br>No adjustment is necessary. |
| PRESET             | The optimum white balance can be obtained under 3200K tungsten lamp.                                |

**Note:** The relationship between white balance modes and remote control mode are listed in the table below.

| White balance mode | Remote control mode |
|--------------------|---------------------|
|                    | RC-Z1/Z11<br>RU-Z1  |
| MEMORY             | MEM1                |
| AUTO               | MEM2/AUTO           |
| PRESET             | PRESET              |

1. Set the SCENE file selector switch to 1, 2, 3 or 4.
2. Select the white balance mode to the MEMORY mode by the FUNC button.
3. Select the filter disk in accordance with the lighting conditions.

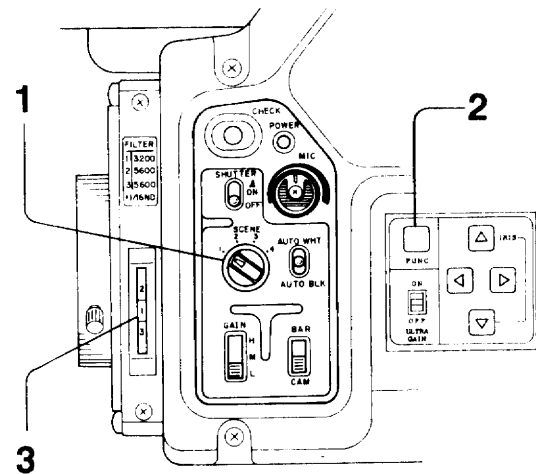

| Filter disk | Color temperature of light source | Light source   |
|-------------|-----------------------------------|--|
| 1           | 3200K                             | Inside studio (lighting by tungsten lamp and halogen lamp)         |
| 2           | 5600K                             | Under fluorescent lamp lighting. Outdoors on a cloudy or rainy day |
| 3           | 5600K + 1/16ND                    | Outdoors on a fine day   |

# Adjustment and operation

4. Set the iris control selector switch of the lens to A.
5. Zoom in a white object (white paper, etc.).  
When large white paper is not available, use an object having a white portion of 10% or more.
6. Set the AUTO WHITE/AUTO BLACK switch to AUTO WHITE. Then, the message is changed as shown below, and white balance is automatically adjusted. The adjusted value is stored in the memory.

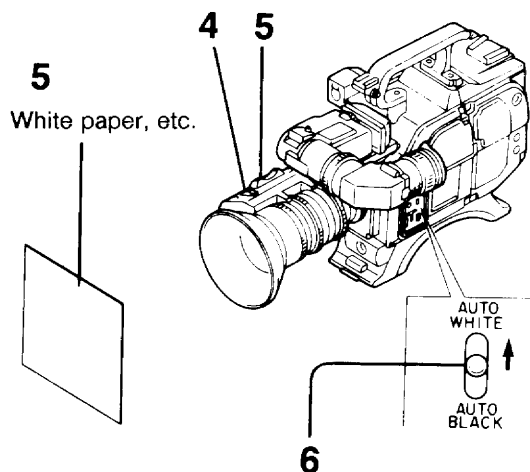
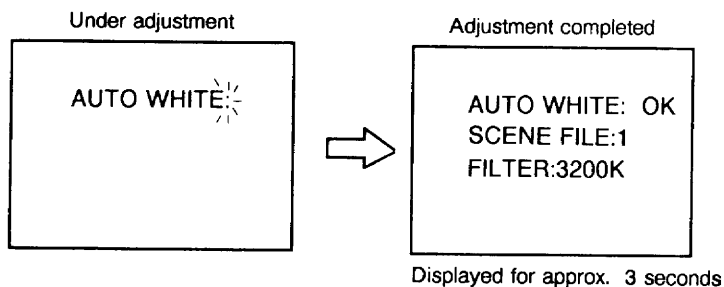

## When white balance cannot be adjusted automatically

The following messages are displayed on the screen for approx. 6 seconds.

| Display   | Cause   | Remedy   |
|---|---|--|
| AUTO WHITE: -NG-<br>CHANGE TO CAM<br>TRY AGAIN                  | The BAR/CAM switch is set to BAR.                       | Set the switch to CAM, and adjust white balance again.   |
| AUTO WHITE: -NG-<br>CHANGE TO<br>MEMORY MODE<br>TRY AGAIN       | The white balance mode switch is set to PRESET or AUTO. | Set to MEMORY mode and adjust white balance again.   |
| AUTO WHITE: -NG-<br>LOW LIGHT<br>TRY AGAIN                      | Quantity of light is too low.                           | Illuminate the object or set the video gain switch to M or H and make sure that the L indicator is not lit. Then adjust white balance again. |
| AUTO WHITE: -NG-<br>C. TEMP. HIGH<br>CHANGE FILTER<br>TRY AGAIN | Color temperature is too high.                          | Change the optical filter, and adjust white balance again.   |
| AUTO WHITE: -NG-<br>C. TEMP. LOW<br>CHANGE FILTER<br>TRY AGAIN  | Color temperature is too low.                           |  |
| AUTO WHITE:<br>TALLY ON<br>EXECUTE ?                            | When the tally lamp is lit                              | When the switch is pressed again while this screen is displayed, adjustment starts.  |







# Adjustment and operation

## Changing settings (Function menu operations)



### Operating method and menu screen structure

It is possible to change various camera mode settings with the menu screen.

#### (1) Controlling the camera operation switch (local mode)

Control the camera operation switch with the **FUNC** button and the , , ,  and buttons.

**FUNC** : Turns the FUNCTION menu ON/OFF.

,  : With the cursor in the first line, switch the main menu on the main menu screen. Press the left arrow on the submenu to return to the host menu.

With the cursor below the first line, revise various mode settings. If the item selected is (: →), press  switch to execute the submenu selected.

,  : These buttons move the cursor.

#### (2) Operating with the special controller (RU-Z1, RC-Z1, RC-Z11) (REMOTE mode).

Operate with the FUNCTION, UP, DOWN and CHECK switch commands.

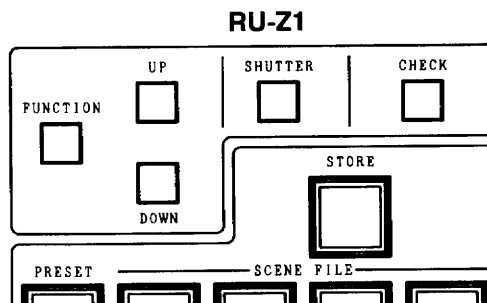

**FUNCTION** : Turn the FUNCTION menu ON. When the menu is ON, the cursor moves.

**CHECK** : Turn the FUNCTION menu OFF.

**UP** : Changes various mode settings.

When the cursor is placed in the first line of the submenu, the screen returns to the host menu.

**DOWN** : Changes various mode settings. When the item selected is (: →), execute the submenu.

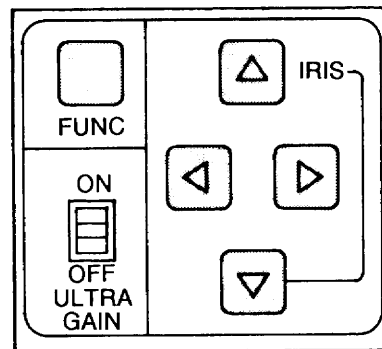

# Adjustment and operation

## (3) Structure of the menu screen.

• In CAM mode

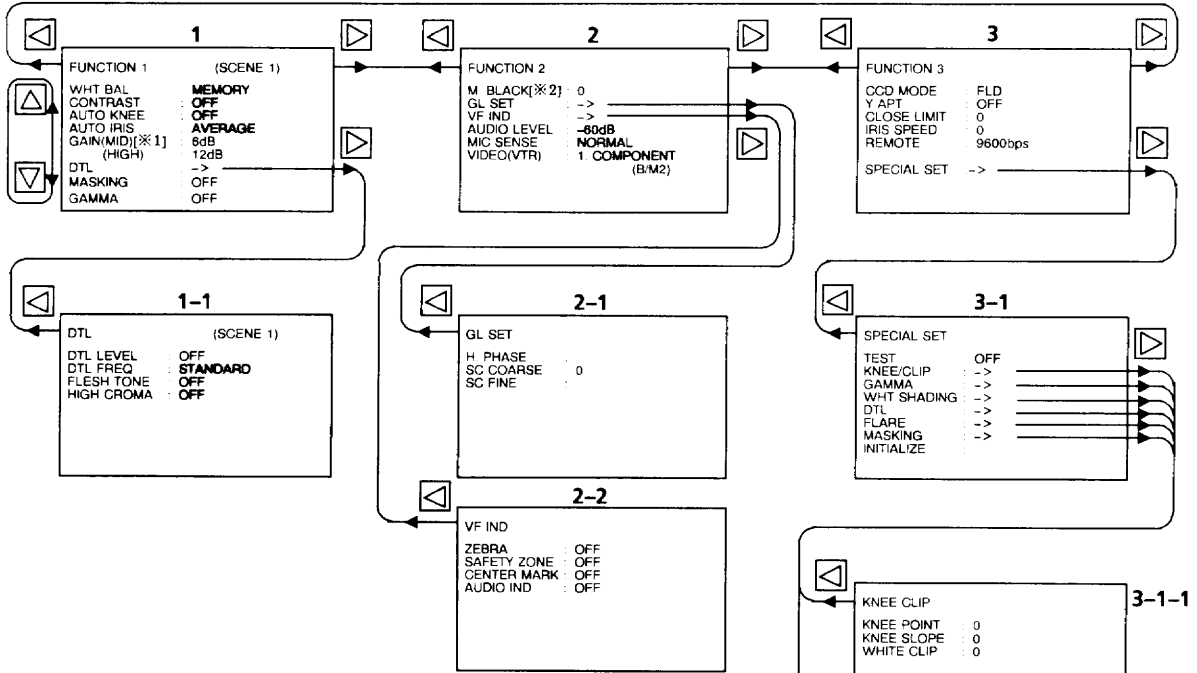

**Note:**

- ※ 1 ULTRA GAIN ON/OFF in remote operation mode.
- ※ 2 Deletion in remote operation mode.

• In BAR mode

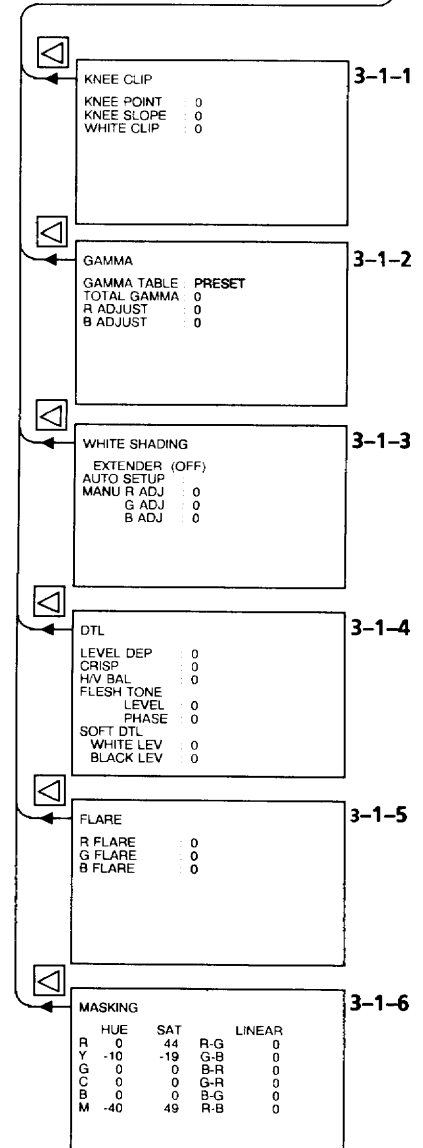
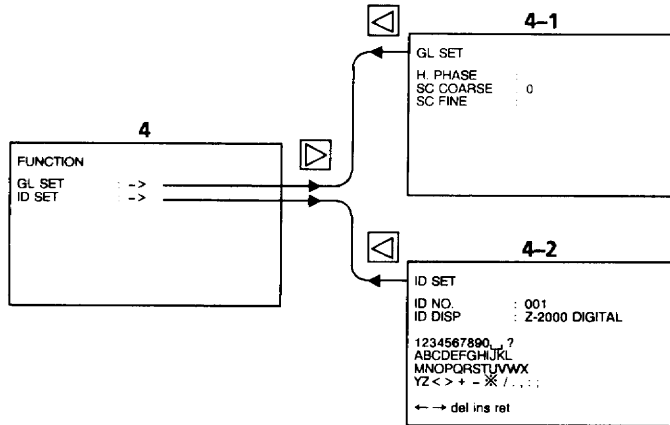

# Adjustment and operation

## (3) Structure of the menu screen.

• In CAM mode

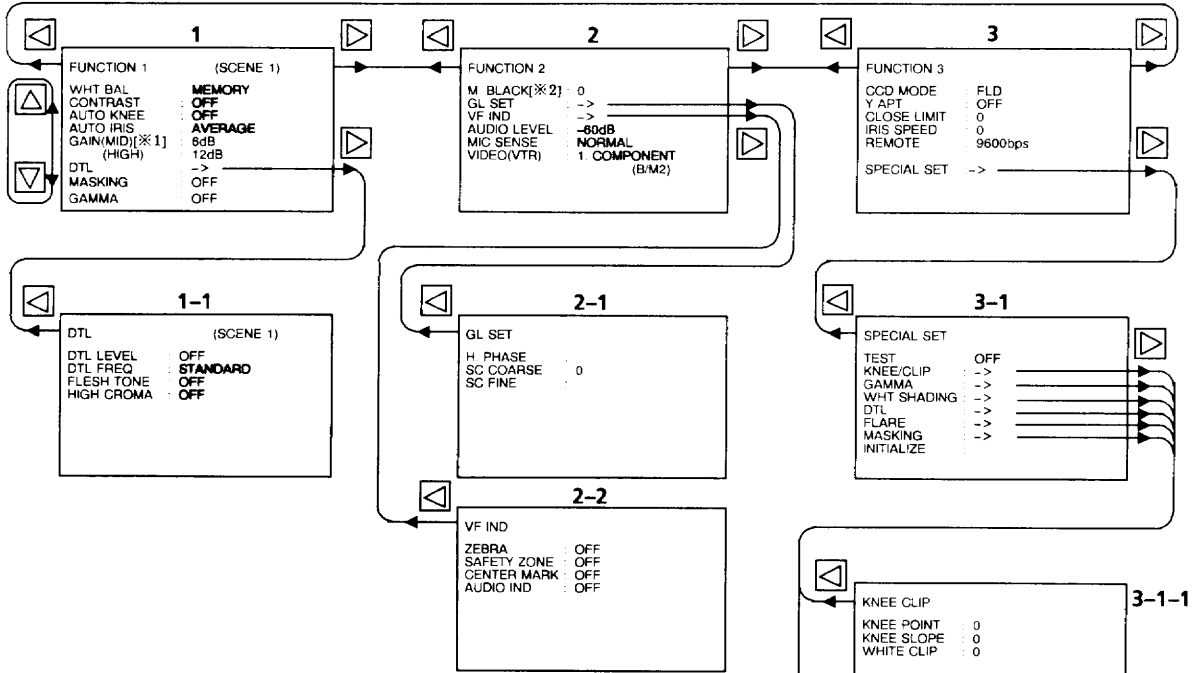

**Note:**

- ※ 1 ULTRA GAIN ON/OFF in remote operation mode.
- ※ 2 Deletion in remote operation mode.

• In BAR mode

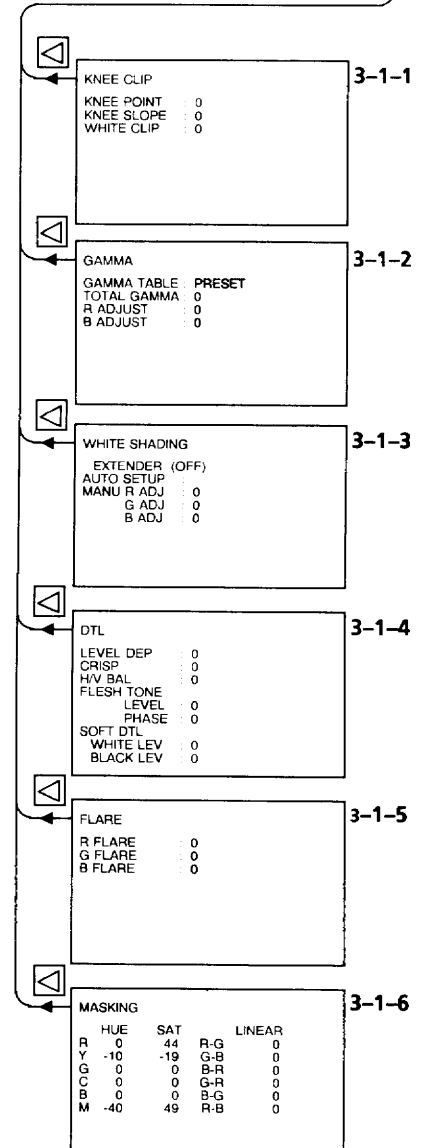
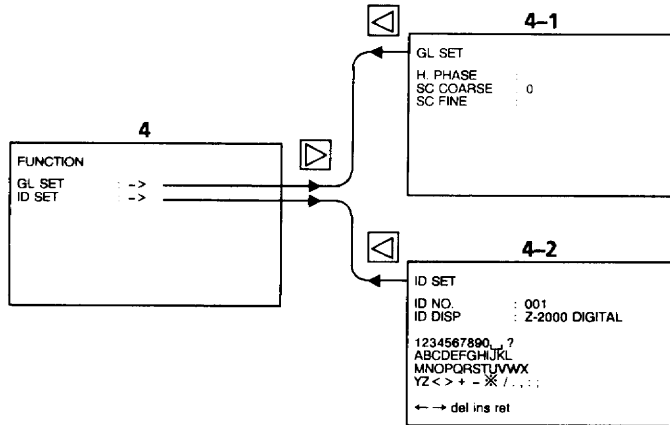







# Adjustment and operation

## (4) List of Items on each menu screen

LEFT  RIGHT  indicates initial pre-set values (pre-shipment values)

### A. Menu when BAR/CAM is switched to CAM Mode.

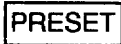
#### 1 FUNCTION 1 (SCENE \*) Main menu (corresponds to scene file)

|            |  |  |
|------------|--|--|
| WHT BAL    | PRESET ⇄ MEMORY ⇄ AUTO   | Choose from PRESET, MEMORY or AUTO.  |
| CONTRAST   |  ⇄ NORMAL ⇄ HIGH  | Choose OFF, NORMAL or HIGH. When the dark area is too dark to see clearly, as with backlighting, select NORMAL or HIGH.  |
| AUTO KNEE  |  ⇄ ON             | Turn the AUTO KNEE ON to obtain a picture with natural highlighting.   |
| AUTO IRIS  |  ⇄ PEAK           | This switches the detection method of the signal level during AUTO IRIS operations.<br><b>AVERAGE:</b> If there is a bright area on the screen, AVERAGE can soften the background (mean method).<br><b>PEAK:</b> This is effective to identify the bright areas, for example clouds (peak value method). |
| GAIN       | (MID) 6dB ⇄ 9dB ⇄ 12dB   | Select 6dB, 9dB, or 12dB.  |
|            | (HIGH) 12dB ⇄ 18dB ⇄ 24dB  | Select 12dB, 18dB, or 24dB.  |
| ULTRA GAIN | OFF ⇄ ON   | <b>ON:</b> Improves sensitivity by about 12dB (however, this only works when the GAIN setting is at least 12dB). The picture quality, including horizontal resolution, deteriorates.<br><b>OFF:</b> Operates in normal mode.   |
| DTL        |                 | Used to execute the DTL submenu.   |
| MASKING    | OFF ⇄  ⇄ MEMORY | <b>MEMORY:</b> Used to correct the color setting using the MASKING submenu.<br><b>PRESET:</b> Used to make standard color corrections.<br><b>OFF:</b> Used to turn off the color correction function.  |
| GAMMA      | OFF ⇄  ⇄ MEMORY | <b>MEMORY:</b> Used to correct the GAMMA setting using the GAMMA submenu.<br><b>PRESET:</b> Used to make standard GAMMA corrections.<br><b>OFF:</b> GAMMA = 1.   |

**Note :** GAIN(MID), (HIGH) : only in local mode



**Note :** ULTRA GAIN : only in remote mode

# Adjustment and operation

## 1-1 DTL (SCENE ※) Submenu (Corresponds to Scene File)

|            |  |  |
|------------|--|--|
| DTL LEVEL  | OFF ⇔ -128 ⇔ <input type="text" value="0"/> ⇔ +127 | OFF/Settings can be anywhere within the range of -128 (minimum) to 0 (standard) and +127 (maximum).                    |
| DTL FREQ   | <input type="text" value="STANDARD"/> ⇔ SHARP      | <b>STANDARD:</b> Used to set DTL frequency at the standard level.<br><b>SHARP:</b> Used to set a higher DTL frequency. |
| FLESH TONE | <input type="text" value="OFF"/> ⇔ ON              | Turn this ON to tone down the flesh color DTL. Use the DTL submenu to set flesh color.                                 |
| HIGH CROMA | <input type="text" value="OFF"/> ⇔ ON              | Turn this ON to improve the resolution in areas of intense color.  |

## 2 FUNCTION 2 Main Menu

|             |   |  |
|-------------|---|--|
| M. BLACK(※) | -128 ⇔ 0 ⇔ +127   | Settings can be anywhere within the range of -128 to 0 (standard) to +127(only in local mode).   |
| GL SET      |    | Used to execute the GL SET submenu.  |
| VF IND      |    | Used to execute the VF IND submenu.  |
| AUDIO LEVEL | <input type="text" value="-60dB"/> ⇔ -20dB  | Depending on the VTR to be connected, the voice level can be set within the range of -60dB and -20dB. (See page 28)  |
| MIC SENS    | LOW ⇔ <input type="text" value="NORMAL"/> ⇔ HIGH  | This is set at NORMAL. Depending on the sensitivity of the microphone, it can be set at LOW or HIGH.   |
| VIDEO(VTR)  | <input type="text" value="1. COMPONENT"/> ⇔ 2. Y/C ⇔<br>(β/M II)   (S-VHS/Hi8)<br>3.            Y/C   ⇔ 4. VBS ⇔<br>(CA-Z1SP)   (U-matic)<br>5. RGB | Switched depending on the VTR to be connected. (See page 28).<br>1. COMPONENT (B/M II)<br>2. Y/C (S-VHS/Hi8)<br>3. Y/C (CA-Z1SP)<br>4. VBS (U-matic)<br>5. R.G.B |

※:only in local mode.

# Adjustment and operation

## 2-1 GL SET Submenu

|            |                    |   |
|------------|--------------------|---|
| H. PHASE   | -128 ⇔ + 127       | Used to adjust the horizontal synchronous phase during GL operations. This can be adjusted within the range of -128 to + 127. |
| SC. COARSE | 0 ⇔ 90 ⇔ 180 ⇔ 270 | Roughly tunes the subcarrier during GL operations. Choose from 0 , 90 , 180 and 270° settings.                                |
| SC. FINE   | -128 ⇔ + 127       | Fine tunes the subcarrier during GL operations. Can be set within the range of -128 to + 127.                                 |

## 2-2 VF IND Sub menu

|             |  |   |
|-------------|--|---|
| ZEBRA       | <input type="checkbox"/> OFF ⇔ <input type="checkbox"/> ON | Turn ZEBRA ON to generate ZEBRA pattern for 90% or more of the picture signals on the viewfinder. |
| SAFETY ZONE | OFF ⇔ <input type="checkbox"/> ON                          | Turn SAFETY ZONE ON to display the shooting safety zone on the viewfinder.                        |
| CENTER MARK | OFF ⇔ <input type="checkbox"/> ON                          | Turn CENTER MARK ON to display the shooting center mark on the viewfinder screen.                 |
| AUDIO IND   | OFF ⇔ <input type="checkbox"/> ON                          | Turn AUDIO IND ON to display the audio level indicator in the upper part of the viewfinder.       |

## 3 FUNCTION 3 Main Menu

|             |                  |   |
|-------------|------------------|---|
| CCD MODE    | FLD ⇔ FRM        | <p><b>FLD:</b> Used to select the field integration mode. The unit is normally used in this mode.</p> <p><b>FRM:</b> Used to select the frame integration mode. (Although this increases vertical resolution, it also increases ghosting. This mode is suitable for freeze picture.)</p>  |
| DSA         | OFF ⇔ ON         | Turns high resolution, DSA(Double Sampling Aperture), mode operations ON or OFF (normally ON).  |
| CLOSE LIMIT | -128 ⇔ 0 ⇔ + 127 | <p>Hunching may occur if the AUTO IRIS is used in very bright conditions, when the aperture is almost closed. Hunching can be prevented by adjusted the close limit value. When the auto electronic shutter (AES) is ON, it operates at a light intensity brighter than the close limit value.</p> <p>When the cursor is moved to CLOSE LIMIT, the lens iris automatically adjusts to the close limit contraction value. When the lens is replaced, adjust to achieve a close limit value of f16.</p> |

# Adjustment and operation

|             |  |   |
|-------------|--|---|
| IRIS SPEED  | -2 ⇄ -1 ⇄ <span style="border: 1px solid black; padding: 2px;">0</span> ⇄ +1 ⇄ +2                  | Adjusts for 6 pin type lens (use lens adjuster for 12 pin type lens).<br>Pressing "+" increases the lens auto iris response speed. Adjust to eliminate hunching.  |
| REMOTE      | <span style="border: 1px solid black; padding: 2px;">62500bps</span> ⇄ 9600 ⇄ 4800<br>⇄ 2400 ⇄ U-4 | Changes baud rate.<br>62500bps: Select for use with RU-Z1, RC-Z1, RC-Z11 and so forth.<br>9600bps, 4800bps, 2400bps: Select for use with RU-Z2, RC-Z2, personal computer and so forth.<br>U-4: Select for use with Canon's pan-tilt system. |
| SPECIAL SET | ➡  | Activates SPECIAL SET submenu.  |

## 3-1 SPECIAL SET Submenu

|             |          |   |
|-------------|----------|---|
| TEST        | OFF ⇄ ON | Turn ON to check camera operations.   |
| KNEE/CLIP   | ➡        | Activates KNEE/CLIP submenu.  |
| GAMMA       | ➡        | Activates GAMMA submenu.  |
| WHT SHADING | ➡        | Activates WHT SHADING submenu.  |
| DTL         | ➡        | Activates DTL submenu.  |
| FLARE       | ➡        | Activates FLARE submenu.  |
| MASKING     | ➡        | Activates MASKING submenu.  |
| INITIALIZE  | ➡        | Initial values are set by simultaneously pressing <span style="border: 1px solid black; padding: 2px;">←</span> , <span style="border: 1px solid black; padding: 2px;">→</span> switches (for camera) and UP, DOWN switches (for controller).<br><b>Note:</b> reset each item to return to previous values. |

### 3-1-1 KNEE/CLIP Submenu

#### SPECIAL Submenu

|            |                 |   |
|------------|-----------------|---|
| KNEE POINT | -128 ⇄ 0 ⇄ +127 | Sets picture signal level where knee function commences operations, in the range from -128 to +127. |
| KNEE SLOPE | -128 ⇄ 0 ⇄ +127 | Sets inclination of knee characteristics, in the range from -128 to +127.                           |
| WHITE CLIP | -128 ⇄ 0 ⇄ +127 | Sets white clip level, in the range from -128 to +127.  |

# Adjustment and operation

## 3-1-2 GAMMA Submenu

|             |                 |  |
|-------------|-----------------|--|
| GAMMA TABLE | PRESET ↔ A ↔ B  | Switch the setting for GAMMA start up.<br>PRESET: Standard setting.<br>A: Slightly high<br>B: Higher   |
| TOTAL GAMMA | -128 ↔ 0 ↔ +127 | The degree of GAMMA correction can be adjusted from the standard setting.<br>It is possible to adjust total GAMMA and to make fine adjustments to the R and B GAMMA.<br>Can be set within the range of -128 to +127. |
| R ADJUST    | -128 ↔ 0 ↔ +127 |  |
| B ADJUST    | -128 ↔ 0 ↔ +127 |  |

## 3-1-3 WHITE SHADING Submenu

Used to correct vertical white shading caused by the lens.

|            |  |   |
|------------|--|---|
| EXTENDER   | OFF ↔ ON   | The lens extender is turned ON when a lens equipped with the extender is attached. (Indication only).<br>The white shading can be set when the lens extender is ON and when it is OFF.          |
| AUTO SETUP | ( Perform the operating procedure listed at right. ) | Used to adjust white shading.<br>First, adjust the G ch shading using menu G ADJ.<br>Next, adjust the auto white using AUTO WHT switch.<br>Then, adjust the auto shading using AUTO BLK switch. |
| MANU       | R ADJ -128 ↔ 0 ↔ +127                                | Used to adjust the manual white shading. Can be set within the range from -128 to +127.   |
|            | G ADJ -128 ↔ 0 ↔ +127                                |   |
|            | B ADJ -128 ↔ 0 ↔ +127                                |   |

## 3-1-4 DTL Submenu

|           |                 |  |
|-----------|-----------------|--|
| LEVEL DEP | -128 ↔ 0 ↔ +127 | Used to set the DTL quantity in dark areas. Can be set within the range from -128 to +127.                                   |
| CRISP     | -128 ↔ 0 ↔ +127 | Used to set the DTL quantity in the flat areas. Can be set within the range from -128 to +127.                               |
| H/V BAL   | -128 ↔ 0 ↔ +127 | Used to set the balance of horizontal DTL quantity and vertical DTL quantity. Can be set within the range from -128 to +127. |



# Adjustment and operation

|            |           |                 |   |
|------------|-----------|-----------------|---|
| FLESH TONE | LEVEL     | -128 ⇔ 0 ⇔ +127 | Used to adjust the DTL quantity for flesh tone from the initial setting to create a smooth picture quality. Can be set within the range from -128 to +127.  |
|            | PHASE     | -128 ⇔ 0 ⇔ +127 | Used to adjust the phase of flesh tone. A marker appears, which is used to indicate the area to be adjusted. (Because it is mixed with green color in the video output main wire, make sure not to operate it during ON AIR.)<br>Can be set within the range from -128 to +127. |
| SOFT DTL   | WHITE LEV | -128 ⇔ 0 ⇔ +127 | Used to reduce excessive contrast details around the edge to create softer pictures. This enables adjustment of light and dark detail signals.<br>Can be set within the range from -128 to +127.  |
|            | BLACK LEV | -128 ⇔ 0 ⇔ +127 |   |

## 3-1-5 FLARE Submenu

|         |                 |   |
|---------|-----------------|---|
| R FLARE | -128 ⇔ 0 ⇔ +127 | Used to adjust the red signal flare correction quantity. Can be set within the range from -128 to +127.   |
| G FLARE | -128 ⇔ 0 ⇔ +127 | Used to adjust the green signal flare correction quantity. Can be set within the range from -128 to +127. |
| B FLARE | -128 ⇔ 0 ⇔ +127 | Used to adjust the blue signal flare collection quantity. Can be set within the range from -128 to +127.  |

## 3-1-6 MASKING Submenu

|        |                 |  |
|--------|-----------------|--|
| HUE    | -128 ⇔ 0 ⇔ +127 | <b><u>R, Y, G, C, B, M (6 color independent masking)</u></b><br>Independently corrects each color, red (R), yellow (Y), green (G), cyan (C), blue (B) and magenta (M), using the parameters of HUE and saturation. Each color can be set in the range from -128 to +127.<br><br><b><u>R-G, G-B, G-R, B-G, R-B (linear matrix)</u></b><br>Sets linear matrix relationship between colors, in the range from -128 to +127. |
| SAT    | -128 ⇔ 0 ⇔ +127 |  |
| LINEAR | -128 ⇔ 0 ⇔ +127 |  |

## B. Menu when BAR/CAM SW is In BAR mode

### 4 Function Main enu

|        |   |                               |
|--------|---|-------------------------------|
| GL SET | ➡ | Activates the GL SET submenu. |
| ID SET | ➡ | Activates the ID IND submenu. |

# Adjustment and operation

## 4-1GL SET Submenu (same as GL SET Submenu when BAR/CAM switch is in CAM Mode)

|           |                    |  |
|-----------|--------------------|--|
| H. PHASE  | -128 ⇄ +127        | Adjusts the horizontal synchronous phase during GL operations, in the range from -128 to +127. |
| SC COARSE | 0 ⇄ 90 ⇄ 180 ⇄ 270 | Coarsely adjusts the subcarrier during GL operations. Select 0 , 90 , 180 or 270° .            |
| SC FINE   | -128 ⇄ +127        | Finely adjusts the subcarrier during GL operations, in the range from -128 to +127.            |

## 4-2 ID SET Submenu

|         |                       |   |
|---------|-----------------------|---|
| ID No.  | Three alphanumerics   | Used to set the ID No. and ID DISP characters.<br>(See below for details) |
| ID DISP | Max. 14 alphanumerics |   |

## ID setting

Used to set the ID No. and ID DISP characters.

**ID No.:** Pressing the ID No. when the unit is controlled from a personal computer enables remote control of cameras whose ID No. corresponds to the one transmitted by the personal computer. The ID No. consists of three characters.

**ID DISP:** It is possible to indicate characters in the bottom right of the screen on the color bar. This can be used to display titles and memos.

### <Setting Up>

The diagram shows a screen titled "ID SET" with the following content:

```

ID SET
ID NO.   : 001
ID DISP  : Z-2000 DIGITAL

1234567890 _ ?
ABCDEFGHIJKLMN
OPQRSTUVWXYZ
YZ < > + - * / . , ;

← → del ins ret
    
```

Annotations on the diagram:

- Character set-up section.→** Points to the "ID NO." and "ID DISP" lines.
- Character input section.→** Points to the character selection lists.
- Soft key.→** Points to the bottom row of characters.
- (1) The character located at the set-up position flickers.** An arrow points to the first '0' in "001".
- (2) Select characters to be input using the [Left], [Right], [Up], [Down] buttons. (They flicker).** An arrow points to the '0' in the input list.
- (3) Press the [FUNC] switch to confirm the characters to be entered. (The cursor located at the set-up position moves only one character at a time.)** An arrow points to the '0' in the input list.

- (1) Press the [Down] button when the cursor is in the ID set title to begin set-up from the first character of the ID number (the character located at the set-up position).
- (2) Use the [Left], [Right], [Up], [Down] buttons to select characters from the input character section. (These characters also flicker.)
- (3) Press the [FUNC] switch to move the character chosen under (2) to the (1) position. (The cursor in the character set-up section moves to the next position, one character at a time.)

# Adjustment and operation

- (4) Repeat steps (2) and (3) to set the ID NO. and ID DISP.
- (5) Select the soft key at the end of step (2) and press the **FUNC** switch to perform a special set up.
  - ← : Moves the cursor in the character set-up section one character to the left.
  - : Moves the cursor in the character set-up section one character to the right.
  - del : Eliminates one character at the cursor position and moves following characters one space to the left.
  - ins : Inserts a space or character in the cursor position and moves following characters one space to the right.
  - ret : Moves the cursor to the header (the ID SET position) to terminate ID set mode. Press the **FUNC** switch to terminate FUNCTION mode.

## Switching the Indication ON and OFF

After entering the characters, it is possible to display or erase ID characters stored in memory.

- (1) Turn the BAR/CAM switch to BAR.
- (2) Press the CHECK button. This displays characters on the viewfinder. At the same time, character signals are superimposed on the color bar output.
- (3) To turn off the character display, press the CHECK button again.

## Fine adjustment of AUTO IRIS

- 1) Do not press the **FUNC** switch, but press the **△** **▽** buttons independently. The screen shown on the right appears in the viewfinder.

When the subject is darkish (as with backlighting), set to +0.5 or +1.

- 2) Use the **△** **▽** buttons to change as follows:

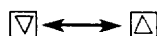
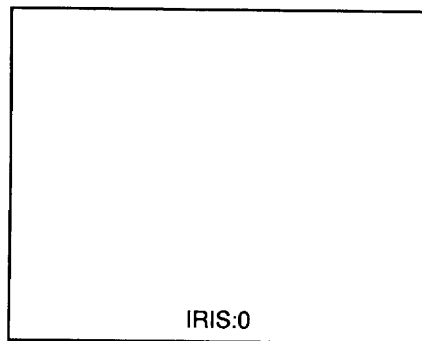
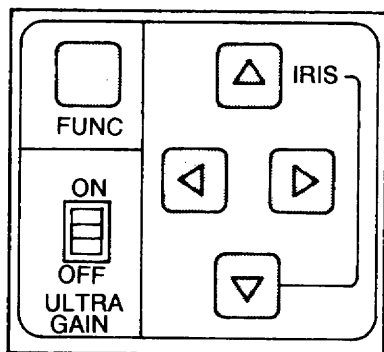

-1 ↔ -0.5 ↔ 0 ↔ +0.5 ↔ +1

↑  
Closes by approx.  
one lens stop.

↑  
Opens by approx.  
one lens stop.

# Adjustment and operation

## Electronic shutter

The electronic shutter can be switched to the following modes:

- **Preset mode:** Possible to choose five shutter speeds, ranging from 1/100 second to 1/2,000 second.
- **Lock scan mode:** Since the shutter speed can be continuously switched in 1H steps, ranging from about 1/60 second to 1/2,000 second, an extensive range of shutter speeds can be set. The display screen, which has a different scanning frequency than the camera, does not cause any flicker.
- **AES mode:** (Automatic Electronic Shutter) This changes the shutter speed in the range from OFF to 1/1,000 second to automatically set a uniform picture level.

### 1. Shutter speed setting in preset mode

- (1) Turn the shutter switch ON to display the following screen in the viewfinder.
- (2) Each time it flips to the upper side, the shutter mode switches in the following order:

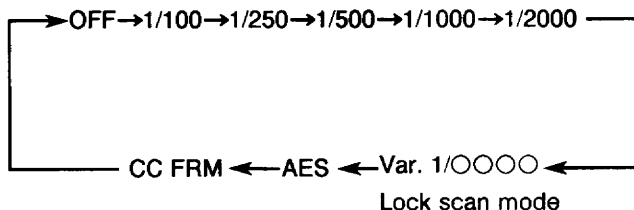

### 2. Setting the shutter speed in lock scan mode

Press the  $\Delta$   $\nabla$  buttons when the Var. 1/○○○○ characters display is ON (about 6 seconds) to change shutter speed as follows:

Adjust the shutter speed to the desired level. When shooting the display screen, which has a different scanning frequency as shown in the figure below, the horizontal bar, which is either bright or dark, scrolls up and down the screen. Press the  $\Delta$  and  $\nabla$  buttons to set the shutter speed in order to minimize horizontal bar fluctuation. This enables you to shoot the display screen without flickering.

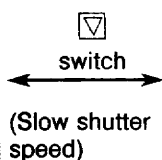
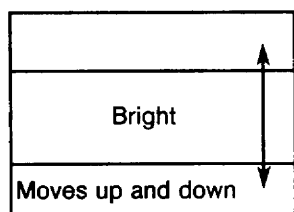
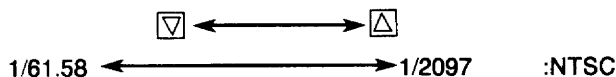
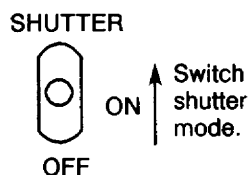
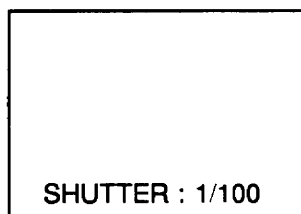

Non-flickering screen.

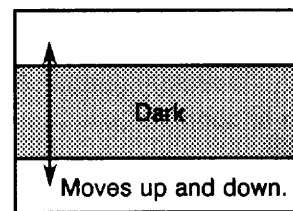
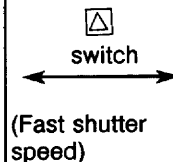
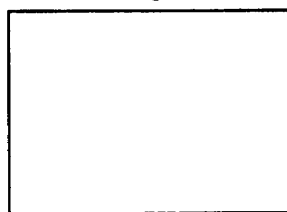

# Adjustment and operation

**(Note 1)** The shutter speed changes by 1H (horizontal frequency) each time the  $\triangle$  or  $\nabla$  button is pressed. The shutter speed continues to change when the button is held down.

**(Note 2)** Press the  $\triangle$  and  $\nabla$  buttons at the same time to set the initial value for the shutter speed. (Minimum variable setting.)

**(Note 3)** When the scanning frequency of the display screen is 60 Hz or less, it is not possible to record a non-flickering image.

**(Note 4)** When the shutter speed accelerates, it is possible to improve the resolution of the picture. However, this deteriorates the sensitivity. Therefore, use artificial light when taking pictures indoors. When the shutter speed increases, the vertical smear increases because of the nature of the CCD camera. This is not a defect.

## 3. AES (Automatic Electronic Shutter) mode

When an auto iris lens is attached to the camera, it automatically switches to the auto iris mode. The lens and iris operate in such a manner that the picture level becomes uniform within the range shown by the chart below at an aperture setting of F=16 against the changes in the input light quantity.

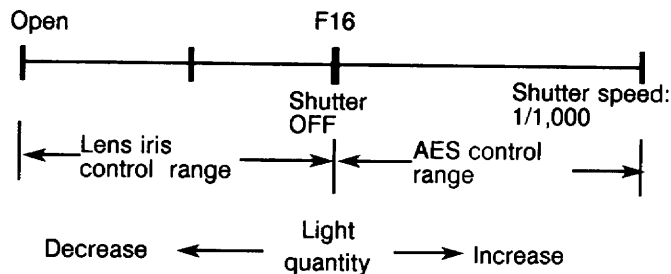

The AES control range is equivalent to changes of 16 times as much as the light quantity (equivalent to four lens stops.)

## 4. CC FRM (CC Frame) mode

Though the vertical resolution is increased, the sensitivity is lowered by one lens stop.

## 5. Using remote control box, RC-Z1/RC-Z11

Cases in Which the Unit is Used in Connection with RC-Z1, RC-Z11

(1) Shutter mode set up: The shutter mode can be set by the camera and by remote control.

When the buttons mode is set by remote control, the following switch is used:

|                | Button Name |
|----------------|-------------|
| RC-Z1/RC-Z11 : | SHUTTER     |

Every time the button is pressed, the shutter mode changes as follows:

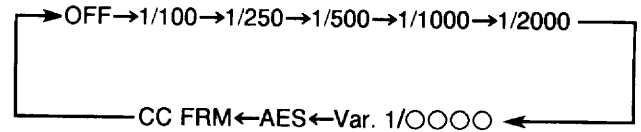

(2) Setting shutter speed in lock scan mode

The shutter speed cannot be set from the remote control. Therefore, set the shutter speed with the switch on the camera.

(3) When the camera is in the AES mode, use the IRIS mode on the remote control in AUTO. (AES does not operate in REMOTE or MANUAL modes.)

## 6. Using RU-Z1

(1) The shutter mode can be set in the same manner as the remote control using the RU-Z1 SHUTTER button.

(2) Shutter speed in lock scan mode can be set as with the camera using the RU-Z1 UP/DOWN switch.

# Adjustment and operation

## Scene files

When shooting several scenes under different conditions, it is necessary to set modes that are suited to each scene. Scene file is a convenient function designed to facilitate such operations. The conditions that suit the scenes to be shot are stored in memory as a file. When the scene changes, the function instantly reads out the file for the new scene. The unit has four files; therefore, it is possible to store four shooting conditions in memory.

### Items Than Can Be Filed

| ITEM  |      | FILE No. | 1                      | 2               | 3               | 4               |
|---|------|----------|------------------------|-----------------|-----------------|-----------------|
|   |      |          |                        |                 |                 |                 |
| <b>Auto white memory, filter disk</b>                     |      |          | Analog data × 3        | Analog data × 3 | Analog data × 3 | Analog data × 3 |
| <b>WHT BAL</b>  |      |          | MEM, AUTO, PRESET      | ←               | ←               | ←               |
| GAIN SEL (Set up of the GAIN when the switch is M and H). | MID  |          | +6, +9, +12            | ←               | ←               | ←               |
|   | HIGH |          | +12, +18, +24          | ←               | ←               | ←               |
| <b>AUTO KNEE</b>  |      |          | ON, OFF                | ←               | ←               | ←               |
| <b>CONTRAST</b>   |      |          | ON, OFF                | ←               | ←               | ←               |
| <b>AUTO IRIS</b>  |      |          | AVERAGE, PEAK          | ←               | ←               | ←               |
| <b>SHUTTER select</b>                                     |      |          | PRESET, LOCK SCAN, AES | ←               | ←               | ←               |
| <b>DTL LEVEL</b>  |      |          | OFF, -128~ +127        | ←               | ←               | ←               |
| <b>DTL FREQ</b>   |      |          | STANDARD, SHARP        | ←               | ←               | ←               |
| <b>FLESH DTL</b>  |      |          | OFF, ON                | ←               | ←               | ←               |
| <b>HI CROMA</b>   |      |          | OFF, ON                | ←               | ←               | ←               |
| <b>MASKING</b>  |      |          | OFF, PRESET, MEMORY    | ←               | ←               | ←               |
| <b>GAMMA</b>  |      |          | OFF, PRESET, MEMORY    | ←               | ←               | ←               |

# Adjustment and operation

## Operating procedure

1. Select the File No. using the SCENE file switch.

2. Set up items that can be filed.

See page 38 to adjust the white balance. See page 40 for other settings.

**Note 1.** In the local mode, when the setting is made, the data in the file selected is replaced.

**Note 2.** Combination with RU-Z1 enables filing of the following items:

- |  |           |
|--|-----------|
| ● R. GAIN  |           |
| ● B. GAIN  |           |
| ● R. BLACK   |           |
| ● B. BLACK   |           |
| ● M. BLACK   |           |
| ● IRIS data  |           |
| ● WHITE BAL mode (PRESET/MEM1/AUTO)                |           |
| ● GAIN (0 to 24dB, in 3dB steps)                   |           |
| ● IRIS mode (AUTO/REMOTE/MANUAL)                   |           |
| ● ULTRA GAIN ON/OFF                                |           |
| ● Auto White Memory Data<br>(For each filter disk) | : Center  |
| ● GAIN   | : 0dB     |
| ● IRIS mode  | : AUTO    |
| ● ULTRA GAIN                                       | : OFF     |
| ● DTL mode   | : NORMAL  |
| ● DTL(Var)   | : OFF     |
| ● AUTO KNEE  | : OFF     |
| ● CONTRAST   | : OFF     |
| ● AUTO IRIS  | : AVERAGE |

### Note 3. PRESET mode

Press the PRESET button (see the chart at the right) of the RU-Z1 scene file to return the set up values for the scene file to the initial settings.

The items and initial settings are shown below:

- |                  |          |
|------------------|----------|
| ● R. GAIN        | : Center |
| ● B. GAIN        | : Center |
| ● R. BLACK       | : Center |
| ● B. BLACK       | : Center |
| ● M. BLACK       | : Center |
| ● IRIS data      | : Center |
| ● WHITE BAL mode | : PRESET |

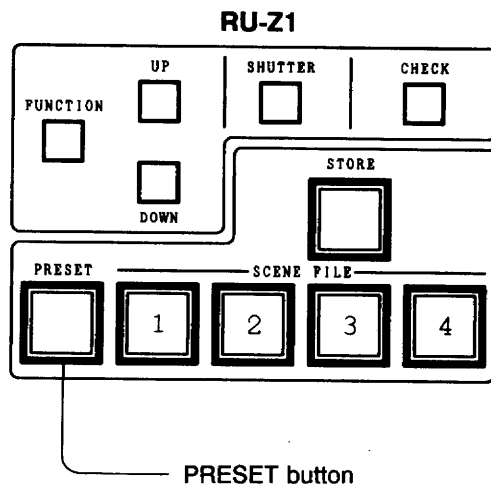

# Genlock

## Example of connection

The camera can be operated in the external sync mode. Supplying an external sync signal automatically switches the internal sync mode to the external sync mode.

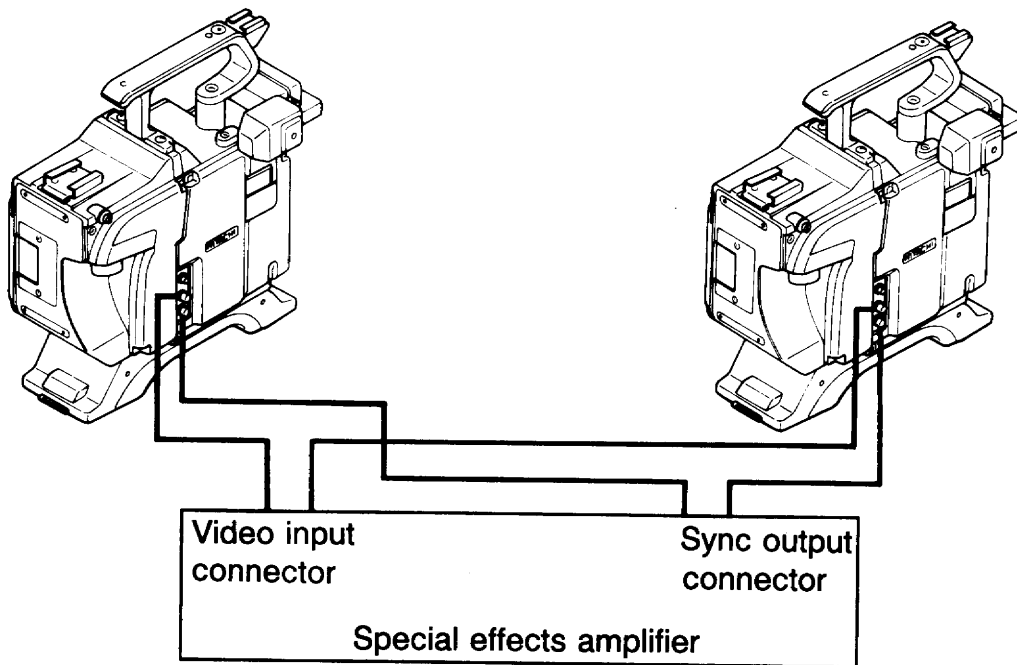

See GL SET function menu (page 43) for genlock adjustment (Horizontal phase and subcarrier phase adjustments).

## What Is Genlock

The horizontal syncphase and subcarrier phase of all the carrier output signals must be matched when two or more cameras are operated concurrently, while connected to devices such as special effects amplifiers. The operator must also synchronize the camera operation with the signals, and the standard signal with the camera. This is called genlock.



# Viewfinder Display

The viewfinder displays the following information:

## Warning and status display

..... The red LED located on the top and bottom outside the screen turns ON.

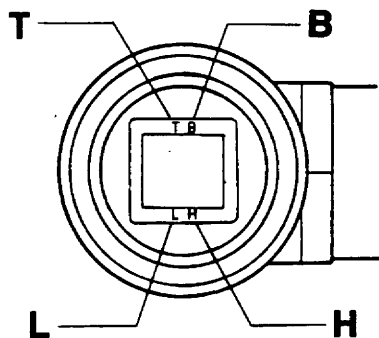

T (tally display) ..... During recording

B (battery alarm) ..... Low battery power.

Charge the battery immediately when the light comes ON.

L (Insufficient light) ..... Insufficient light on the object being shot. When the light comes on, increase the light intensity or switch the GAIN switch to high gain mode.

H (high gain mode) ..... The unit is operating with the picture circuit gain at the high level, 6dB, 9dB, 12dB, 18dB, or 24dB.

## Status display on viewfinder screen

It is possible to change to the following five display modes using switches:

Turn the camera power source ON.

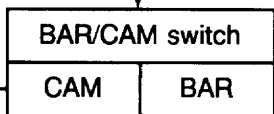

CAM mode(status display 1)

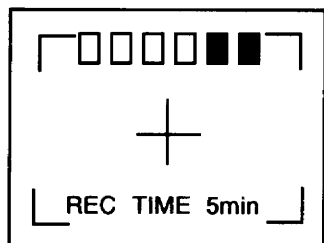

BAR mode

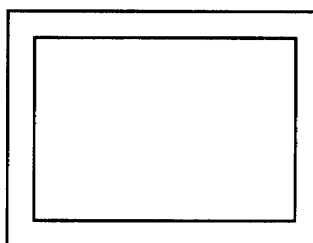

ID display mode  
(See page 48)

Press the CHECK button.

CHECK mode (Status display 2)

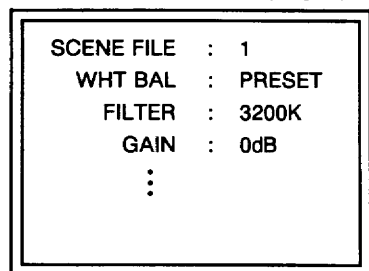

Press the FUNCTION button

FUNCTION mode

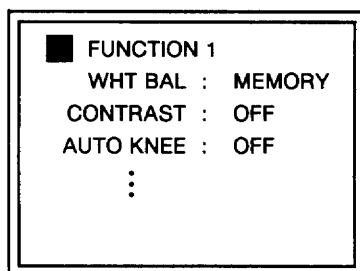

(See page 42.)

Operate buttons other than the FUNCTION and CHECK button.

One line display mode

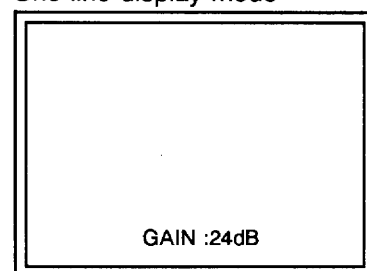

# Display of viewfinder

## ●CAM mode (Status display 1)

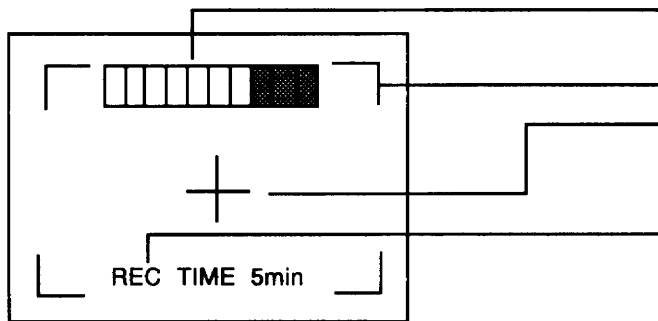

Audio level indicator (see Note 1)

Safety marker

Center marker

Display of REC TIME or remaining TAPE portion. (When the VTR is connected and when the figure changes, the display is visible for about 6 seconds.)

- Remaining TAPE portion is displayed when the unit is BETA CAM or MII.

$\left( \begin{array}{l} t > 15\text{min} \\ t > 10\text{min} \\ t > 5\text{min} \\ t > 2\text{min} \\ t < 2\text{min} \\ \text{end} \end{array} \right)$

- When another VTR is used, REC TIME is displayed.

(The TALLY ON time is detected and counted every minute.)

(Turning the  $\triangle$  and  $\nabla$  buttons ON simultaneously resets the value to 0 min.)

### (Notes)

#### 1. Audio Level Indicator

When the output level of the microphone increases, the number of  $\square$  increases, and when the output level of the microphone exceeds the appropriate level,  $\blacksquare$  is displayed. When the camera adaptor CA-Z1A is installed, the sound output level from the camera is displayed. When the VTR is used while connected to the camera, the VTR feedback signal level is displayed.

- #### 2. The audio level indicator and the center marker can be turned ON or OFF on the FUNCTION screen. (See page 44.)

#### 3. Display of recording time

The recording time is displayed by calculating the time the unit is ON. When the time exceeds 100 min., it returns to 1 min.

## ●CHECK mode (Status display 2)

Press the CHECK button to display the following screen for 6 seconds:

### ●Status display 2-1

|              |        |
|--------------|--------|
| SCENE FILE : | 1      |
| WHITE BAL :  | PRESET |
| FILTER :     | 3200K  |
| GAIN :       | 0dB    |
| ULTRA GAIN:  | OFF    |
| SHUTTER :    | OFF    |
| DTL :        | NORMAL |

- 2, 3, 4
- MEMORY, AUTO
- 5600K, 5600K + ND
- 6dB, 9dB, 12dB, 18dB, 24dB (Note 1)
- ON
- 1/100, 1/250, 1/500, 1/1000, 1/2000, Var. AES, CC FRM
- OFF, -128 ~ +127

### (Note)

1. When the unit is connected to an RU-Z1, the display can be changed in 3dB increments, from 0 - 24dB.

# Display of viewfinder

## ●CAM mode (Status display 1)

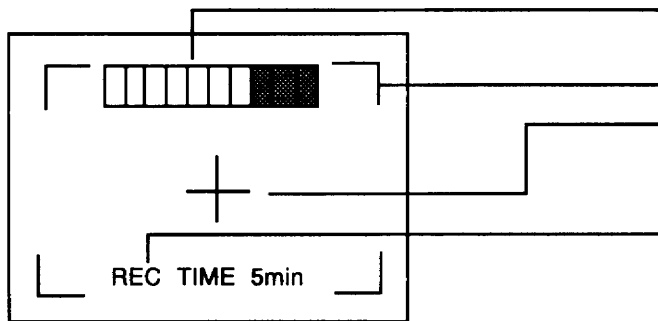

Audio level indicator (see Note 1)

Safety marker

Center marker

Display of REC TIME or remaining TAPE portion. (When the VTR is connected and when the figure changes, the display is visible for about 6 seconds.)

- Remaining TAPE portion is displayed when the unit is BETA CAM or MII.

$\left( \begin{array}{l} t > 15\text{min} \\ t > 10\text{min} \\ t > 5\text{min} \\ t > 2\text{min} \\ t < 2\text{min} \\ \text{end} \end{array} \right)$

- When another VTR is used, REC TIME is displayed.

(The TALLY ON time is detected and counted every minute.)

(Turning the  $\triangle$  and  $\nabla$  buttons ON simultaneously resets the value to 0 min.)

### (Notes)

#### 1. Audio Level Indicator

When the output level of the microphone increases, the number of  $\square$  increases, and when the output level of the microphone exceeds the appropriate level,  $\blacksquare$  is displayed. When the camera adaptor CA-Z1A is installed, the sound output level from the camera is displayed. When the VTR is used while connected to the camera, the VTR feedback signal level is displayed.

- #### 2. The audio level indicator and the center marker can be turned ON or OFF on the FUNCTION screen. (See page 44.)

#### 3. Display of recording time

The recording time is displayed by calculating the time the unit is ON. When the time exceeds 100 min., it returns to 1 min.

## ●CHECK mode (Status display 2)

Press the CHECK button to display the following screen for 6 seconds:

### ●Status display 2-1

|                    |   |
|--------------------|---|
| SCENE FILE : 1     | ● 2, 3, 4   |
| WHITE BAL : PRESET | ● MEMORY, AUTO  |
| FILTER : 3200K     | ● 5600K, 5600K + ND                                     |
| GAIN : 0dB         | ● 6dB, 9dB, 12dB, 18dB, 24dB (Note 1)                   |
| ULTRA GAIN: OFF    | ● ON  |
| SHUTTER : OFF      | ● 1/100, 1/250, 1/500, 1/1000, 1/2000, Var. AES, CC FRM |
| DTL : NORMAL       | ● OFF, -128 ~ +127                                      |

### (Note)

1. When the unit is connected to an RU-Z1, the display can be changed in 3dB increments, from 0 - 24dB.

# Viewfinder Display

Press the CHECK button again while the status display 2-1 screen is ON to display the following screen for about 6 seconds:

## ●Status display 2-2

|           |   |         |
|-----------|---|---------|
| MASKING   | : | OFF     |
| AUTO KNEE | : | OFF     |
| CONTRAST  | : | OFF     |
| ZEBRA     | : | OFF     |
|           |   |         |
| TAPE IND. | : | 15min   |
| BAATT:E   | : | ..... F |

PRESET, MEMORY

ON

ON

ON

REC TIME : 5min (See Note 1)

BATTERY: 12.5Volt (See Note 2)

Press the CHECK button again while the status display 2-2 screen is ON to return to status display 1 (CAM mode).

### (Notes)

1. REC TIME or remaining time portion will be displayed.
2. Battery voltage or remaining battery power is displayed.

### ●One Line Display Mode (Switch Display Mode)

Using the following switch, it is possible to display the switch status in one line:

- ① GAIN
- ② SHUTTER
- ③ SCENE
- ④ FILTER DISK
- ⑤ AUTO BLK/WHT
- ⑥ IRIS (Local mode only)
- ⑦ ULTRA GAIN (Local mode only)
- ⑧ LENS EXTENDER

# Display of viewfinder screen

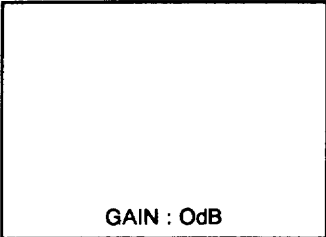
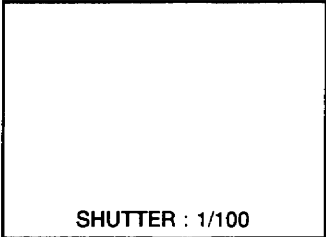
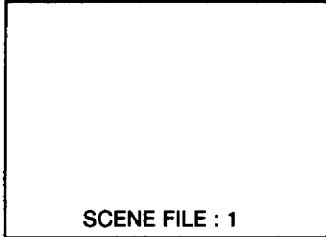
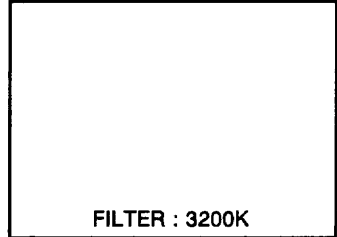
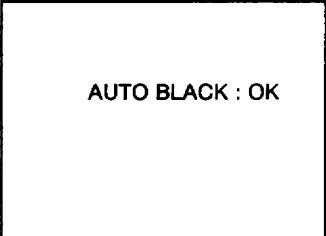
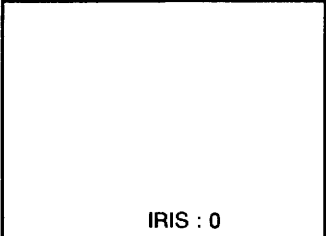
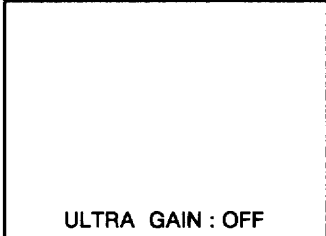
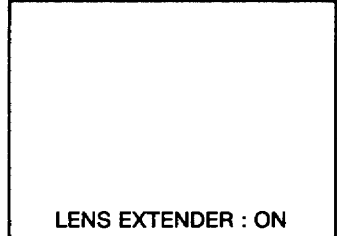
|   |  |  |  |
|---|--|--|--|
| ①   | ②  | ③  | ④  |
|  <p style="text-align: center;">GAIN : 0dB<br/>(See Note 1)</p>                                   |  <p style="text-align: center;">SHUTTER : 1/100<br/>(See page 50)</p> |  <p style="text-align: center;">SCENE FILE : 1<br/>(See Note 2)</p>    |  <p style="text-align: center;">FILTER : 3200K<br/>FILTER:5600K,<br/>5600K + ND</p> |
| ⑤   | ⑥  | ⑦  | ⑧  |
|  <p style="text-align: center;">AUTO BLACK : OK<br/>AUTO WHITE: OK<br/>(See pages 37 and 39.)</p> |  <p style="text-align: center;">IRIS : 0<br/>(See page 49.)</p>       |  <p style="text-align: center;">ULTRA GAIN : OFF<br/>ULTRA GAIN:ON</p> |  <p style="text-align: center;">LENS EXTENDER : ON<br/>LENS EXTENDER:OFF</p>        |

## Note 1. GAIN display

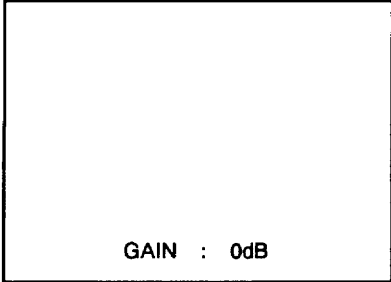
|  |  |   |   |       |                  |       |                              |   |        |                                |       |  |   |                   |                     |                     |                     |                     |   |                   |                     |   |
|--|--|---|---|-------|------------------|-------|------------------------------|---|--------|--------------------------------|-------|--|---|-------------------|---------------------|---------------------|---------------------|---------------------|---|-------------------|---------------------|---|
|  | <p>In local mode</p> <p>In remote mode (in combination with RU-Z1)</p> | <table border="0"> <tr> <td rowspan="2" style="font-size: 3em; vertical-align: middle;">{</td> <td>(LOW)</td> <td>GAIN: <u>0dB</u></td> </tr> <tr> <td>(MID)</td> <td>GAIN: 6dB, <u>9dB</u>, 12dB</td> </tr> <tr> <td rowspan="2" style="font-size: 3em; vertical-align: middle;">{</td> <td>(HIGH)</td> <td>GAIN: 12dB, <u>18dB</u>, 24dB</td> </tr> <tr> <td>ULTRA</td> <td>GAIN: <u>0dB</u>, 3dB, 6dB, 9dB, 12dB, 15dB, 18dB, 21dB, 24dB</td> </tr> <tr> <td rowspan="4" style="font-size: 3em; vertical-align: middle;">{</td> <td rowspan="4" style="vertical-align: middle;">ULTRA<br/>GAIN: ON</td> <td>GAIN:12dB + U. GAIN</td> </tr> <tr> <td>GAIN:15dB + U. GAIN</td> </tr> <tr> <td>GAIN:18dB + U. GAIN</td> </tr> <tr> <td>GAIN:21dB + U. GAIN</td> </tr> <tr> <td rowspan="2" style="font-size: 3em; vertical-align: middle;">{</td> <td rowspan="2" style="vertical-align: middle;">ULTRA<br/>GAIN: ON</td> <td>GAIN:0dB, 9dB, 18dB</td> </tr> <tr> <td>(in combination with models other than RU-Z1)</td> </tr> </table> | { | (LOW) | GAIN: <u>0dB</u> | (MID) | GAIN: 6dB, <u>9dB</u> , 12dB | { | (HIGH) | GAIN: 12dB, <u>18dB</u> , 24dB | ULTRA | GAIN: <u>0dB</u> , 3dB, 6dB, 9dB, 12dB, 15dB, 18dB, 21dB, 24dB | { | ULTRA<br>GAIN: ON | GAIN:12dB + U. GAIN | GAIN:15dB + U. GAIN | GAIN:18dB + U. GAIN | GAIN:21dB + U. GAIN | { | ULTRA<br>GAIN: ON | GAIN:0dB, 9dB, 18dB | (in combination with models other than RU-Z1) |
| {  | (LOW)  | GAIN: <u>0dB</u>  |   |       |                  |       |                              |   |        |                                |       |  |   |                   |                     |                     |                     |                     |   |                   |                     |   |
|  | (MID)  | GAIN: 6dB, <u>9dB</u> , 12dB  |   |       |                  |       |                              |   |        |                                |       |  |   |                   |                     |                     |                     |                     |   |                   |                     |   |
| {  | (HIGH)   | GAIN: 12dB, <u>18dB</u> , 24dB  |   |       |                  |       |                              |   |        |                                |       |  |   |                   |                     |                     |                     |                     |   |                   |                     |   |
|  | ULTRA  | GAIN: <u>0dB</u> , 3dB, 6dB, 9dB, 12dB, 15dB, 18dB, 21dB, 24dB  |   |       |                  |       |                              |   |        |                                |       |  |   |                   |                     |                     |                     |                     |   |                   |                     |   |
| {  | ULTRA<br>GAIN: ON  | GAIN:12dB + U. GAIN   |   |       |                  |       |                              |   |        |                                |       |  |   |                   |                     |                     |                     |                     |   |                   |                     |   |
|  |  | GAIN:15dB + U. GAIN   |   |       |                  |       |                              |   |        |                                |       |  |   |                   |                     |                     |                     |                     |   |                   |                     |   |
|  |  | GAIN:18dB + U. GAIN   |   |       |                  |       |                              |   |        |                                |       |  |   |                   |                     |                     |                     |                     |   |                   |                     |   |
|  |  | GAIN:21dB + U. GAIN   |   |       |                  |       |                              |   |        |                                |       |  |   |                   |                     |                     |                     |                     |   |                   |                     |   |
| {  | ULTRA<br>GAIN: ON  | GAIN:0dB, 9dB, 18dB   |   |       |                  |       |                              |   |        |                                |       |  |   |                   |                     |                     |                     |                     |   |                   |                     |   |
|  |  | (in combination with models other than RU-Z1)   |   |       |                  |       |                              |   |        |                                |       |  |   |                   |                     |                     |                     |                     |   |                   |                     |   |

## 2. SCENE FILE display

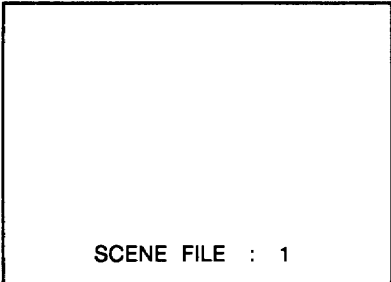
|   |  |   |   |              |              |              |              |   |              |              |              |              |                   |
|---|--|---|---|--------------|--------------|--------------|--------------|---|--------------|--------------|--------------|--------------|-------------------|
|  | <p>In local mode</p> <p>In remote mode (in combination with RU-Z1)</p> | <table border="0"> <tr> <td rowspan="4" style="font-size: 3em; vertical-align: middle;">{</td> <td>SCENE FILE:1</td> </tr> <tr> <td>SCENE FILE:2</td> </tr> <tr> <td>SCENE FILE:3</td> </tr> <tr> <td>SCENE FILE:4</td> </tr> <tr> <td rowspan="5" style="font-size: 3em; vertical-align: middle;">{</td> <td>SCENE FILE:1</td> </tr> <tr> <td>SCENE FILE:2</td> </tr> <tr> <td>SCENE FILE:3</td> </tr> <tr> <td>SCENE FILE:4</td> </tr> <tr> <td>SCENE FILE:PRESET</td> </tr> </table> | { | SCENE FILE:1 | SCENE FILE:2 | SCENE FILE:3 | SCENE FILE:4 | { | SCENE FILE:1 | SCENE FILE:2 | SCENE FILE:3 | SCENE FILE:4 | SCENE FILE:PRESET |
| {   | SCENE FILE:1   |   |   |              |              |              |              |   |              |              |              |              |                   |
|   | SCENE FILE:2   |   |   |              |              |              |              |   |              |              |              |              |                   |
|   | SCENE FILE:3   |   |   |              |              |              |              |   |              |              |              |              |                   |
|   | SCENE FILE:4   |   |   |              |              |              |              |   |              |              |              |              |                   |
| {   | SCENE FILE:1   |   |   |              |              |              |              |   |              |              |              |              |                   |
|   | SCENE FILE:2   |   |   |              |              |              |              |   |              |              |              |              |                   |
|   | SCENE FILE:3   |   |   |              |              |              |              |   |              |              |              |              |                   |
|   | SCENE FILE:4   |   |   |              |              |              |              |   |              |              |              |              |                   |
|   | SCENE FILE:PRESET  |   |   |              |              |              |              |   |              |              |              |              |                   |

# Use in studio system

## Connection of remote operation unit RU-Z1

When connecting the remote operation unit RU-Z1, the camera can be remotely controlled. The distance between the camera and the RU-Z1 can be extended

up to approx. 300m. In addition, intercom between the camera and the RU-Z1 is possible. Further, a 5-inch viewfinder can be installed.

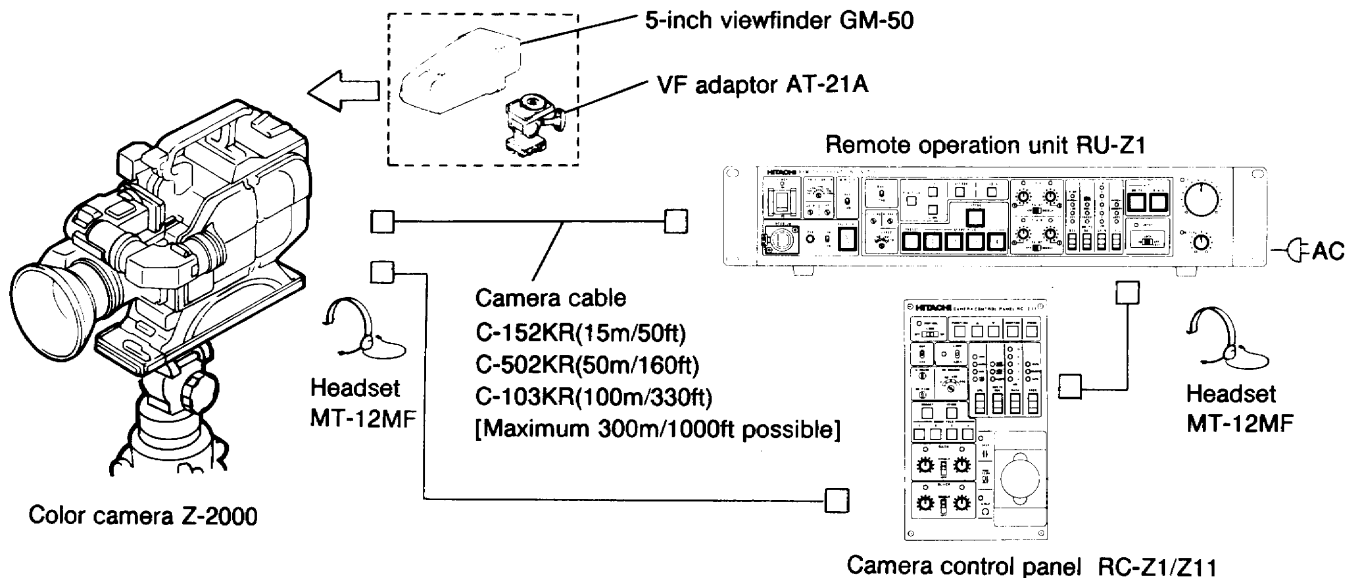

- For details of operation, refer to the operation manual of remote operation unit RU-Z1 or camera control panel RC-Z1/Z11

## Installation of ROU adaptor unit into the camera adaptor

When the RU-Z1 remote operation unit is connected, install the ROU adaptor unit supplied with the RU-Z1 into the CA-Z1A camera adaptor as illustrated below.

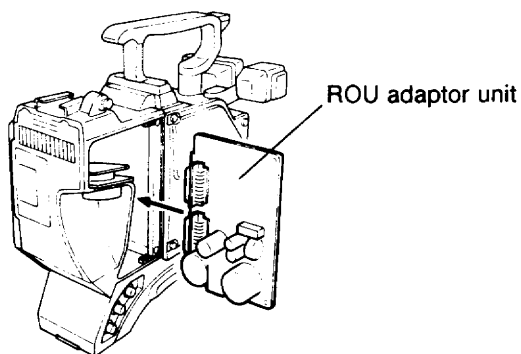

### \* Remote control Items

- R gain and B gain
- Master black level
- B black level and R black level
- Gain (0 to 24dB)
- White balance mode
- Auto white/auto black
- Iris mode and iris control
- Shutter mode\*
- DTL mode
- Status check function\*
- Change of various setting functions by FUNC button \*
- Genlock adjustment (SC phase and horizontal phase)

# Use in studio system

- BAR/CAM
- Other function (RU-Z1)
- Intercom, tally, call
- Cable length correction

**Note:** The items marked with \* are controllable at the camera side even when the RU-Z1 is connected.

The camera control panel RC-Z1/Z11 can be connected to the camera head or the RU-Z1.

When the RC-Z1/RC-Z11 is connected to the camera head, the RC-Z1 or the RC-Z11 has the priority.

## Control items by personal computer

The camera can be controlled by the serial data sent from the RC-Z1/Z11.

Therefore, the camera can be controlled from your personal computer which delivers the RS-232C signal, without using the RC-Z1/Z11. In this case the RS-232C level converter JU-C20 is necessary. Since the software for your personal computer is not supplied, create the program by referring to the manual supplied with the JU-C20.

The RU-Z1 is provided with the RS-232C input connector. Therefore, the JU-C20 is not required to control the camera from a personal computer via the RU-Z1. To control the camera from the personal computer, it is needed to change a communication rate. (See page 45.)

## Mic output level setting

When the remote operation unit RU-Z1 is used, set the mic output level of the camera to -20dBm.(See page 43.)

## Output signal from RGB connector of RU-Z1

Any of the following signals is available from the RGB connector of the RU-Z1.

Select the desired signal in the FUNCTION mode. (See page 43.)

| Connector | Output signal |           |     |     |
|-----------|---------------|-----------|-----|-----|
|           | RGB           | Component | Y/C | VBS |
| R         | R             | R-Y       | C   | -   |
| G         | G             | Y         | Y   | VBS |
| B         | B             | B-Y       | -   | -   |

## Note

1. The 1.5-inch viewfinder and the 5-inch viewfinder cannot be connected at the same time.

# System applications

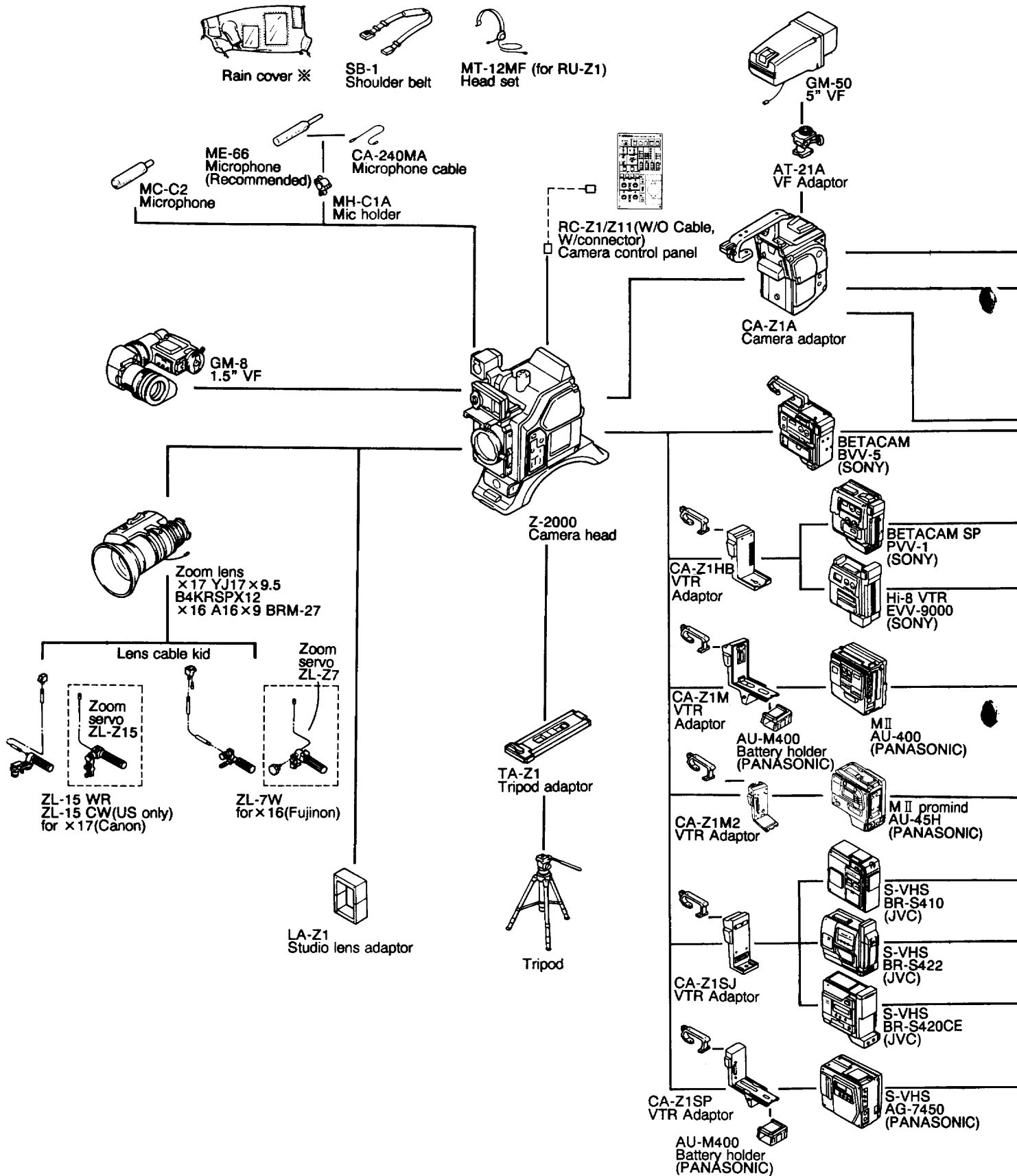



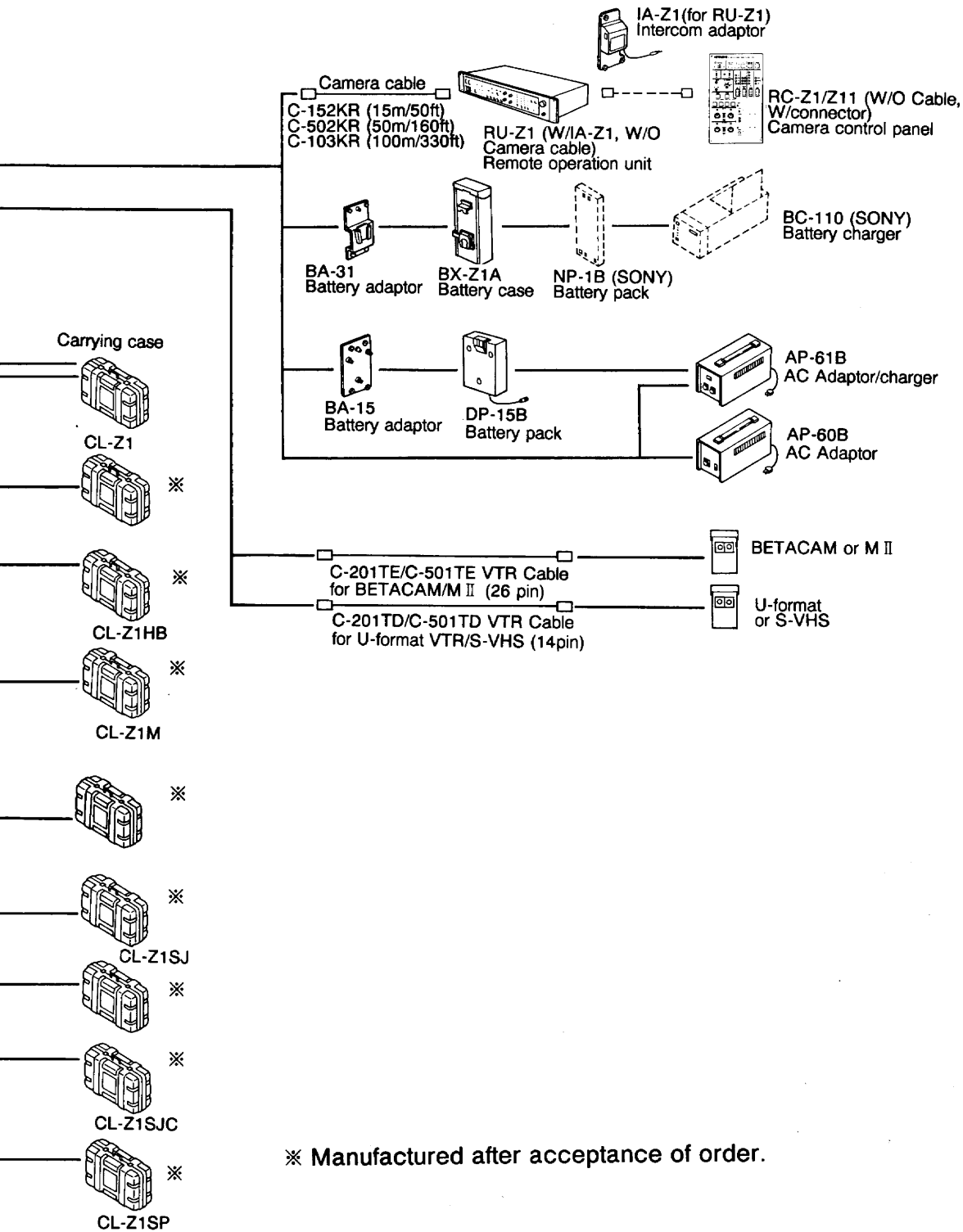

※ Manufactured after acceptance of order.

# Specifications

## Camera head and camera adaptor CA-Z1A

|   |  |
|---|--|
| Color system:                           | NTSC (RS-170A)   |
| Optical system:                         | 2/3" f1.4 prism  |
| Pickup system:                          | RGB 3-CCD system   |
| Imaging device:                         | 2/3 inch CCD with micro lenses   |
| Number of effective pixels              | 754(H)x485(V)  |
| Encoder system:                         | Wideband color difference  |
| Sync system:                            | Internal or genlock (automatic switching)  |
| Horizontal resolution:                  | 850 TV lines (luminance signal, at center, DSA ON, DTL OFF)  |
| S/N:                                    | 62dB typ<br>(gamma = 1, DTL OFF, GAIN: 0dB, Y OUT)   |
| Standard sensitivity:                   | 2,000 lx, f8   |
| Minimum sensitivity:                    | 1.5 lx (f1.8, GAIN: +24dB, ULTRA GAIN: ON)   |
| Gamma correction:                       | 0.35 to 1.0 (ON/OFF switchable)  |
| Optical filter:                         | 3200K, 5600K, 5600K + 1/16ND   |
| Vertical contour correction:            | 2H   |
| Lens mount:                             | Bayonet (B.F. = 48mm in air)   |
| Sensitivity switching:                  | L (LOW): 0dB<br>M(MID): +6, +9, +12dB<br>H (HIGH): +12, +18, +24dB<br>Remote control mode: 0 to +24dB (in 3dB steps)(when RU-Z1 is used)   |
| DTL control                             | DTL level, DTL FREQ, Flesh tone, Hi Chroma, Level DEP, CRISP, H/V BAL, Soft DTL, etc.  |
| Scene file                              | 4 scenes<br>Filed items(8 items): Auto white memory, gain(in MID and HIGH gain mode), DTL level, AUTO IRIS MODE, AUTO KNEE ON/OFF, CONTRAST ON/OFF, MASKING, GAMMA ON/OFF                          |
| ULTRA GAIN function:                    | When the read-out mode of the CCD is changed, sensitivity is increased by approx. 12dB. (This function is available only when sensitivity is +12dB or more, but horizontal resolution is lowered.) |
| Electronic shutter:                     | CC FRAME, 1/100, 1/250, 1/500, 1/1000, 1/2000 s  |
| Lock scan mode                          | 1/61.5 to 1/2000 (1H steps)  |
| AES mode                                | Up to the value equivalent to 4 lens stops   |
| Color bars                              | SMPTE  |
| Output signals:                         |  |
| Video output 1 (BNC)                    | VBS: 1.0Vp-p/75 ohms   |
| Video output 2 (28-pin multi-connector) | VBS: 1.0Vp-p/75 ohms   |
| Video output 3 (28-pin multi-connector) | VBS: 1.0Vp-p/75 ohms   |
| Y/C output (28-pin multiconnector)      | Y: 1.0Vp-p/75 ohms<br>C: 0.286Vp-p (burst)/75 ohms   |
| RGB output (28-pin multi-connector)     | R:0.7Vp-p/75ohms<br>G:0.7Vp-p/75ohms<br>B:0.7Vp-p/75ohms   |

# Specifications

Component output(28-pin multi-connector)

VS: 1.0Vp-p/75 ohms

R-Y, B-Y: 0.7Vp-p/75 ohms (BETACAM, 75% color bars)  
0.525Vp-p/75 ohms (M II, 75% color bar)

Audio output (28-pin multiconnector)

-20dBm or -60dBm/600Ω

**Note:** Video output 3, Y/C, RGB or component signal selected by the FUNCTION switch is fed from the CA-Z1A multi-connector.

Genlock input (BNC or 28-pin multi-connector, unusable simultaneously)

VBS: 1.0Vp-p ±3dB or black burst/75 ohms  
(Sync: 0.3 ±0.1Vp-p, Burst: 0.3 ±0.1Vp-p)

Viewfinder AUX input (28-pin multi-connector)

VBS: 1.0Vp-p ±3dB/75 ohms

Remote control input (4-pin or 28-pin multi-connector.

4-pin has priority.)

Power requirement:

1.5Vp-p/High, serial data  
12V DC (10.5 to 17V DC)

Power consumption:

15W (including 1.5-inch viewfinder, excluding CA-Z1A)

Dimensions:

120(W)x293(H)x156(D)mm (excluding CA-Z1A)

Mass:

3.7kg approx. (including 1.5-inch viewfinder and excluding lens and CA-Z1A)

## 1.5-Inch viewfinder GM-8

Input signal:

VS 1Vp-p, sync negative

CRT:

1.5-inch, black and white

Resolution:

600 TV lines approx. (horizontal at center)

LED display:

B,T,L,H

Controls:

Brightness, contrast, peaking, front tally ON/OFF

Power requirement:

9V DC

Power consumption:

1.4W approx.

Mass:

0.6kg approx.

Ambient temperature

Operation

-10 to 45°C

Storage

-20 to 60°C

# Specifications

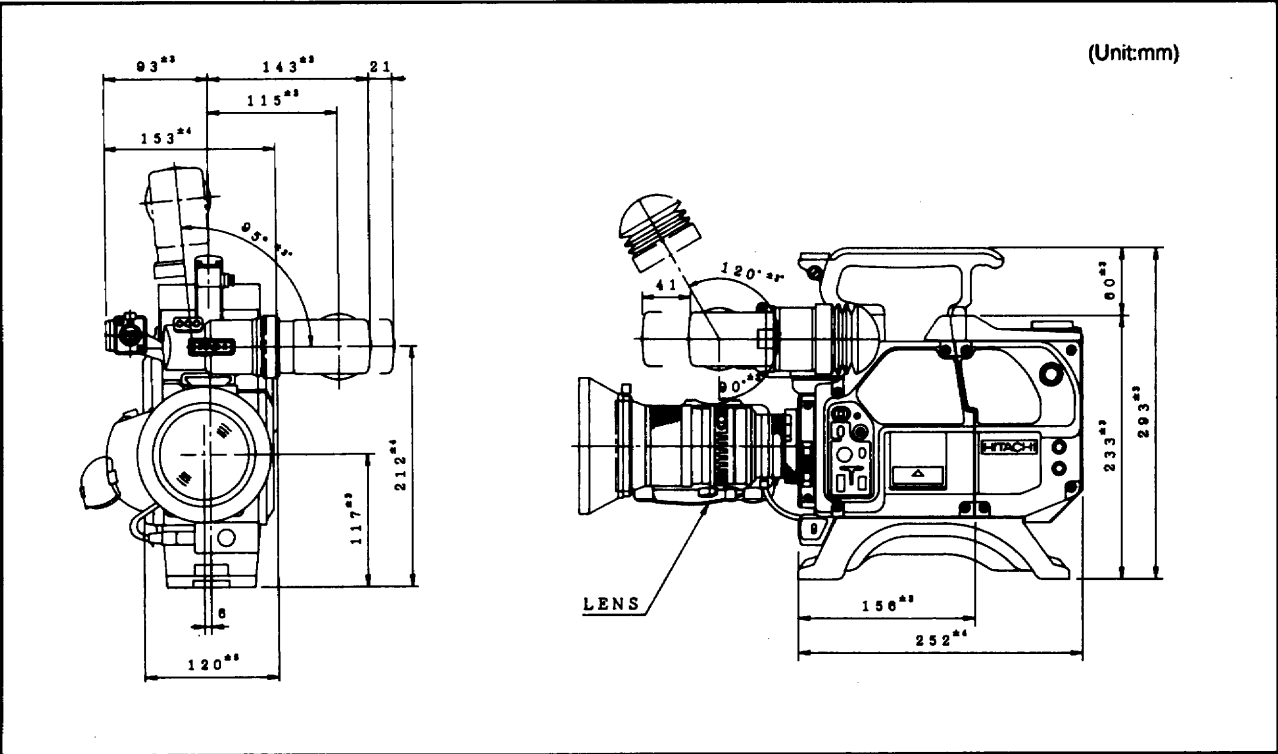

The specifications and the external view are subject to change without notice for improvement.

# Optional accessories and related equipment

For details, contact your nearest Hitachi Denshi sales representative.

## ● Lenses and related kits

- 16X zoom lens A16×9BRM-27
- 17X zoom lens YJ17×9.5B4KRS PX12
- Lens cable kit (for Canon ×17 lens) ZL-15WR
- Lens cable kit (for Fujinon ×16 lens) ZL-15CW
- Lens cable kit (for Fujinon ×16 lens) ZL-7W

## ● 1.5-Inch viewfinder\*

GM-8

## ● Tripod adaptor\*

TA-Z1

## ● Camera adaptor

CA-Z1A (for RU-Z1)

## ● Carrying case\*

CL-Z1

## ● Battery-related products

- Battery pack DP-15B
- Battery adaptor BA-15

## ● AC adaptor/charger-related products

- AC adaptor AP-60B
- AC adaptor/charger AP-61B

## ● Shoulder belt

SB-1

## ● Microphone-related products

- Microphone MC-C2
- Microphone holder (for ME-66) MH-C1A (for ME-66)
- Mic cable C-240MA (for ME-66)

## ● Camera control unit-related products

- Remote operation unit RU-Z1
- Camera control panel RC-Z1
- Camera control panel RC-Z11
- RS-232C level converter JU-C20
- Camera cable, 15m C-152KR (for RU-Z1)
- Camera cable, 50m C-502KR (for RU-Z1)
- Camera cable, 100m C-103KR (for RU-Z1)

## ● Headset

- Dynamic mic type (for RU-Z1) MT-12MF (for RU-Z1)

# Optional accessories and related equipment

## ●VTR adaptor

- |   |         |
|---|---------|
| ●VTR adaptor (for S-VHS Panasonic)      | CA-Z1SP |
| ●VTR adaptor (for S-VHS JVC)            | CA-Z1SJ |
| ●VTR adaptor [for Hi8, Betacam (PVV-1)] | CA-Z1HB |
| ●VTR adaptor (for M II )                | CA-Z1M  |
| ●VTR adaptor (for M II Promind, AU-45H) | CA-Z1M2 |

## ● VTR cables

- |                                    |                      |
|------------------------------------|----------------------|
| ●VTR cable (for S-VHS/U-matic), 2m | C-201TD (for CA-Z1A) |
| ●VTR cable (for S-VHS/U-matic), 5m | C-501TD (for CA-Z1A) |
| ●VTR cable (for Betacam/M II ), 2m | C-201TE (for CA-Z1A) |
| ●VTR cable (for Betacam/M II ), 5m | C-501TE (for CA-Z1A) |

## ●5-inch viewfinder-related products

- |                                  |        |
|----------------------------------|--------|
| ●5-inch viewfinder               | GM-50  |
| ●VF adaptor (for mounting GM-50) | AT-21A |

## ●For maintenance

- |                                    |       |
|------------------------------------|-------|
| ●Extension board (for PS, MIC/VTR) | EXT-3 |
| ●Extension board                   | EXT-1 |

The accessories are subject to change without notice for improvement.

# Information for service person

**EXT 12V IN(4-pin, male)**

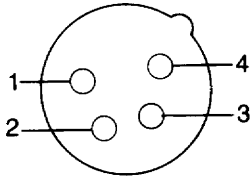

| Pin | Signal     |
|-----|------------|
| 1   | GND        |
| 2   | NC         |
| 3   | NC         |
| 4   | +12V input |

**BATT 12V IN(13-pin, male)**

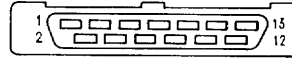

| pin | Signal | pin | Signal |
|-----|--------|-----|--------|
| 1   | +12V   | 8   | NC     |
| 2   | NC     | 9   | NC     |
| 3   | NC     | 10  | NC     |
| 4   | NC     | 11  | NC     |
| 5   | NC     | 12  | NC     |
| 6   | GND    | 13  | NC     |
| 7   | NC     |     |        |

**REMOTE((4-pin, female)**

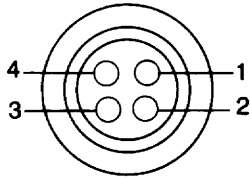

| Pin | Signal     |
|-----|------------|
| 1   | +9V output |
| 2   | SD input   |
| 3   | SD output  |
| 4   | SD GND     |

**VF(8-pin, male)**

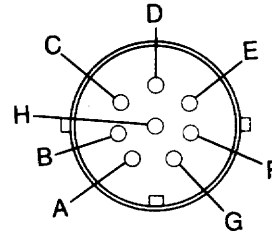

| Pin | Signal         |
|-----|----------------|
| A   | BATT ALM       |
| B   | H. IND         |
| C   | VF 9V          |
| D   | +12V           |
| E   | L. IND         |
| F   | VF VIDEO (VBS) |
| G   | GND            |
| H   | VF TALLY       |

**LENS(12-pin, female)**

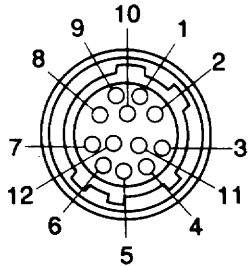

| Pin | Signal        |
|-----|---------------|
| 1   | AUX SW        |
| 2   | CALL/TRIG     |
| 3   | GND           |
| 4   | ENF AUTO      |
| 5   | IRIS CONTROL  |
| 6   | +12V          |
| 7   | IRIS POSITION |
| 8   | NC            |
| 9   | NC            |
| 10  | NC            |
| 11  | NC            |
| 12  | NC            |

**MIC(3-pin, female)**

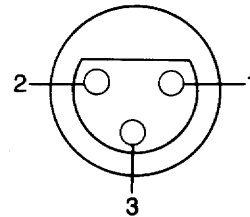

| Pin | Signal   |
|-----|----------|
| 1   | MIC GND  |
| 2   | MIC L IN |
| 3   | MIC R IN |

**ROU/VTR(28-pin, male)**

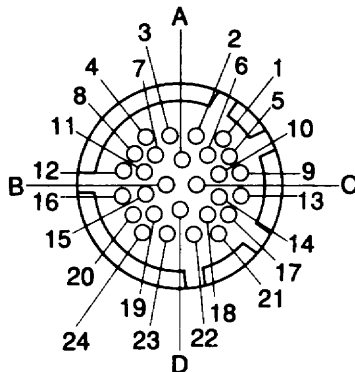

| Pin | Signal      | Pin | Signal        | Pin | Signal    |
|-----|-------------|-----|---------------|-----|-----------|
| A   | +12V        | 7   | G/Y/VBS       | 17  | INCOM L1  |
| B   | +40V        | 8   | B/B-Y         | 18  | CALL/TRIG |
| C   | GND         | 9   | AUDIO(L) +    | 19  | SYNC/CHR  |
| D   | GND         | 10  | AUDIO(L) -    | 20  | AUX GND   |
| 1   | GL GND      | 11  | COLOR FRAME   | 21  | GND       |
| 2   | GL          | 12  | VTR VIDEO     | 22  | INCOM L2  |
| 3   | R. G. B GND | 13  | VTR SAVE      | 23  | SD        |
| 4   | R/R-Y/C     | 14  | BATT ALM      | 24  | AUX VIDEO |
| 5   | VTR TRIG    | 15  | SD GND        |     |           |
| 6   | REC/TALLY   | 16  | VTR VIDEO GND |     |           |