

## WARNING

To reduce the risk of fire or shock hazard, do not expose the TV to rain or moisture.

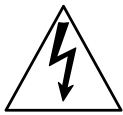

This symbol is intended to alert the user to the presence of uninsulated "dangerous voltage" within the product's enclosure that may be of sufficient magnitude to constitute a risk of electric shock to persons.

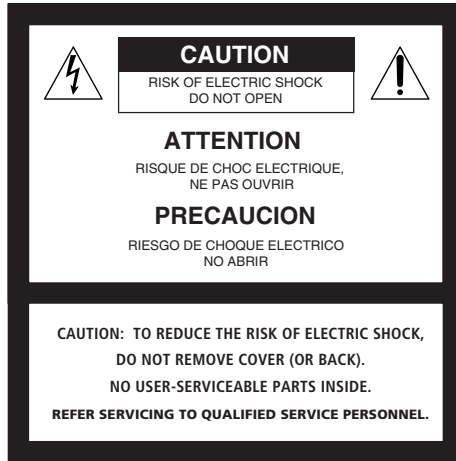

This symbol is intended to alert the user to the presence of important operating and maintenance (servicing) instructions in the literature accompanying the appliance.

## CAUTION

TO PREVENT ELECTRIC SHOCK, MATCH WIDE BLADE OF PLUG TO WIDE SLOT, FULLY INSERT.

## CAUTION

When using TV games, computers, and similar products with your TV, keep the brightness and contrast functions at low settings. If a fixed (non-moving) pattern is left on the screen for long periods of time at a high brightness or contrast setting, the image can be permanently imprinted onto the screen. Continuously watching the same program can cause the imprint of station logos onto the TV screen. These types of imprints are not covered by your warranty because they are the result of misuse.

## Note on Caption Vision

This television receiver provides display of television closed captioning in accordance with §15.119 of the FCC rules.

## Note on Cleaning the TV

Clean the TV with a soft dry cloth. Never use strong solvents such as thinner or benzene, which might damage the finish of the cabinet.

## Note to CATV System Installer

This reminder is provided to call the CATV system installer's attention to Article 820-40 of the NEC that provides guidelines for proper grounding and, in particular, specifies that the cable ground shall be connected to the grounding system of the building, as close to the point of cable entry as practical.

Use of this television receiver for other than private viewing of programs broadcast on UHF or VHF or transmitted by cable companies for the use of the general public may require authorization from the broadcaster/cable company and/or program owner.

## NOTIFICATION

This equipment has been tested and found to comply with the limits for a Class B digital device pursuant to Part 15 of the FCC Rules. These limits are designed to provide reasonable protection against harmful interference in a residential installation. This equipment generates, uses, and can radiate radio frequency energy and, if not installed and used in accordance with the instructions, may cause harmful interference with radio communications. However, there is no guarantee that interference will not occur in a particular installation. If this equipment does cause harmful interference to radio or television reception, which can be determined by turning the equipment off and on, the user is encouraged to try to correct the interference by one or more of the following measures:

- Reorient or relocate the receiving antennas.
- Increase the separation between the equipment and receiver.
- Connect the equipment into an outlet on a circuit different from that to which the receiver is connected.
- Consult the dealer or an experienced radio/TV technician for help.

You are cautioned that any changes or modifications not expressly approved in this manual could void your authority to operate this equipment.

## Safety

- Operate the TV only on 120 V AC.
- The plug is designed, for safety purposes, to fit into the wall outlet only one way. If you are unable to insert the plug fully into the outlet, contact your dealer.
- If any liquid or solid object should fall inside the cabinet, unplug the TV immediately and have it checked by qualified service personnel before operating it further.

## Installing

- To prevent internal heat buildup, do not block the ventilation openings.
- Do not install the TV in a hot or humid place, or in a place subject to excessive dust or mechanical vibration.
- The AC power cord is attached to the rear of the TV with hooks. Do not attempt to remove the cord from these hooks. Doing so could cause damage to the TV.

## Owner's Record

The model and serial numbers are provided on the front of this instruction manual and at the rear of the TV. Refer to them whenever you call upon your Sony dealer regarding this product.

## Trademark Information



TruSurround is a trademark of SRS Labs, Inc. SRS and the SRS symbol are registered trademarks of SRS Labs, Inc. in the United States and selected foreign countries. SRS and TruSurround are incorporated under license from SRS Labs, Inc. and is protected under United States Patent Nos. 4,748,669 and 4,841,572 with numerous additional issued and pending foreign patents. Purchase of this product does not convey the right to sell recordings made with the TruSurround technology.



Manufactured under license from Dolby Laboratories Licensing Corporation. Dolby and the double-D symbol are trademarks of Dolby Laboratories Licensing Corporation.

XBR is a registered trademark and CineMotion is a trademark of Sony.

BBE and BBE Symbol are trademarks of BBE Sound, Inc. and are licensed by BBE Sound, Inc. under U.S. Patent No. 4,638,258 and 4,482,866.

i.LINK is a trademark of Sony used only to designate that a product contains an IEEE 1394 connector. All products with an i.LINK connector may not communicate with each other.

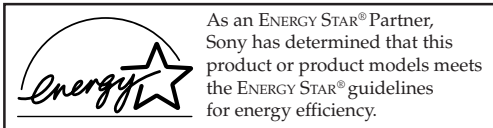

ENERGY STAR® is a U.S. registered mark.

# Important Safeguards

For your protection, please read these instructions completely, and keep this manual for future reference.

Carefully observe and comply with all warnings, cautions and instructions placed on the set or described in the operating instructions or service manual.

## WARNING

To guard against injury, the following basic safety precautions should be observed in the installation, use and servicing of the set.

## Use

### Power Sources

This set should be operated only from the type of power source indicated on the serial/model plate. If you are not sure of the type of electrical power supplied to your home, consult your dealer or local power company. For those sets designed to operate from battery power, refer to the operating instructions.



### Grounding or Polarization

This set is equipped with a polarized AC power cord plug (a plug having one blade wider than the other), or with a three-wire grounding type plug (a plug having a third pin for grounding). Follow the instructions below:

#### For the set with a polarized AC power cord plug

This plug will fit into the power outlet only one way. This is a safety feature. If you are unable to insert the plug fully into the outlet, try reversing the plug. If the plug still fails to fit, contact your electrician to have a suitable outlet installed. Do not defeat the safety purpose of the polarized plug by forcing it in.



#### Alternate Warning

#### For the set with a three-wire grounding type AC plug

This plug will only fit into a grounding-type power outlet. This is a safety feature. If you are unable to insert the plug into the outlet, contact your electrician to have a suitable outlet installed. Do not defeat the safety purpose of the grounding plug.

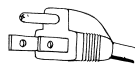

### Overloading

Do not overload wall outlets, extension cords or convenience receptacles beyond their capacity, since this can result in fire or electric shock.

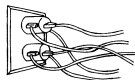

Always turn the set off when it is not being used. When the set is left unattended and unused for long periods of time, unplug it from the wall outlet as a precaution against the possibility of an internal malfunction that could create a fire hazard.



If a snapping or popping sound from a TV set is continuous or frequent while the TV is operating, unplug the TV and consult your dealer or service technician. It is normal for some TV sets to make occasional snapping or popping sounds, particularly when being turned on or off.



### Object and Liquid Entry

Never push objects of any kind into the set through the cabinet slots as they may touch dangerous voltage points or short out parts that could result in a fire or electric shock. Never spill liquid of any kind on the set.



### Cleaning

Unplug the set from the wall outlet before cleaning or polishing it. Do not use liquid cleaners or aerosol cleaners. Use a cloth lightly dampened with water for cleaning the exterior of the set.



### Installation

#### Attachments

Do not use attachments not recommended by the manufacturer, as they may cause hazards.

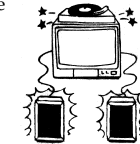

#### Water and Moisture

Do not use power-line operated sets near water — for example, near a bathtub, washbowl, kitchen sink, or laundry tub, in a wet basement, or near a swimming pool, etc.



#### Accessories

Do not place the set on an unstable cart, stand, table or shelf. The set may fall, causing serious injury to a child or an adult and serious damage to the set. Use only a cart or stand recommended by Sony for the specific model of TV. No part of the TV set should overhang any edge of the TV cart or stand; any overhanging edge is a safety hazard. An appliance and cart combination should be moved with care. Quick stops, excessive force, and uneven surfaces may cause the appliance and cart combination to overturn.



### Ventilation

The slots and openings in the cabinet and in the back or bottom are provided for necessary ventilation. To ensure reliable operation of the set, and to protect it from overheating, these slots and openings must never be blocked or covered.

- ❑ Never cover the slots and openings with a cloth or other materials.
- ❑ Never block the slots and openings by placing the set on a bed, sofa, rug or other similar surface.
- ❑ Never place the set in a confined space, such as a bookcase or built-in cabinet, unless proper ventilation is provided.
- ❑ Do not place the set near or over a radiator or heat register, or where it is exposed to direct sunlight.



## Power-Cord Protection

Do not allow anything to rest on or roll over the power cord, and do not place the set where the power cord is subject to wear or abuse.



## About the Unit's High Glossy Finish

The unit surface is finished with high glossy paint. Due to the nature of this finish the following precautions must be observed to avoid discoloration, distortion and scratch marks.

- ❑ Do not bang the TV with any items or objects.
- ❑ Do not place any hot coffee cups and/or heavy items, such as a vase, on top of the TV. (Any water seepage may cause fire or electric shock.)

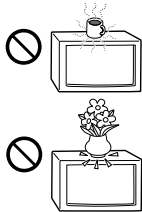

## Antennas

### Outdoor Antenna Grounding

If an outdoor antenna is installed, follow the precautions below. An outdoor antenna system should not be located in the vicinity of overhead power lines or other electric light or power circuits, or where it can come in contact with such power lines or circuits.

WHEN INSTALLING AN OUTDOOR ANTENNA SYSTEM, EXTREME CARE SHOULD BE TAKEN TO KEEP FROM CONTACTING SUCH POWER LINES OR CIRCUITS AS CONTACT WITH THEM IS ALMOST INVARIABLY FATAL.

Be sure the antenna system is grounded so as to provide some protection against voltage surges and built-up static charges. Section 810 of the National Electrical Code (NEC) in USA and Section 54 of the Canadian Electrical Code in Canada provides information with respect to proper grounding of the mast and supporting structure, grounding of the lead-in wire to an antenna discharge unit, size of grounding conductors, location of antenna discharge unit, connection to grounding electrodes, and requirements for the grounding electrode.

### Antenna Grounding According to the NEC

Refer to section 54-300 of Canadian Electrical Code for Antenna Grounding.

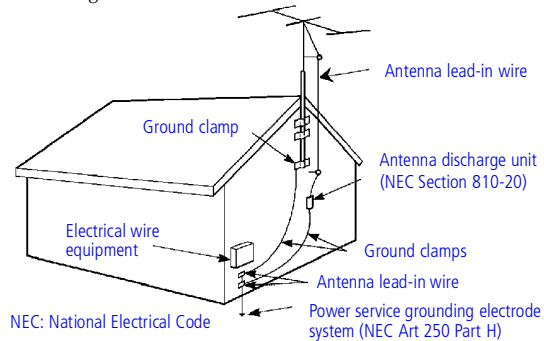







## Lightning

For added protection for this television receiver during a lightning storm, or when it is left unattended and unused for long periods of time, unplug it from the wall outlet and disconnect the antenna. This will prevent damage to the receiver due to lightning and power-line surges.

## Service

### Damage Requiring Service

Unplug the set from the wall outlet and refer servicing to qualified service personnel under the following conditions:

- ❑ When the power cord or plug is damaged or frayed. 
- ❑ If liquid has been spilled into the set. 
- ❑ If the set has been exposed to rain or water. 
- ❑ If the set has been subject to excessive shock by being dropped, or the cabinet has been damaged. 
- ❑ If the set does not operate normally when following the operating instructions. Adjust only those controls that are specified in the operating instructions. Improper adjustment of other controls may result in damage and will often require extensive work by a qualified technician to restore the set to normal operation. 
- ❑ When the set exhibits a distinct change in performance, it indicates a need for service. 

### Servicing

Do not attempt to service the set yourself since opening the cabinet may expose you to dangerous voltage or other hazards. Refer all servicing to qualified service personnel. 

### Replacement Parts

When replacement parts are required, be sure the service technician certifies in writing that he has used replacement parts specified by the manufacturer that have the same characteristics as the original parts.

Unauthorized substitutions may result in fire, electric shock or other hazards.

### Safety Check

Upon completion of any service or repairs to the set, ask the service technician to perform routine safety checks (as specified by the manufacturer) to determine that the set is in safe operating condition, and to so certify. When the set reaches the end of its useful life, improper disposal could result in a picture tube implosion. Ask a qualified service technician to dispose of the set. 



---

# Contents

## *Introducing the Digital TV (DTV)*

Overview .....	1
Presenting the FD Trinitron Wega.....	1
Features.....	2
Package Contents .....	3
Using the Remote Control.....	3
Frequently Asked Questions .....	7

## *Connecting and Setting Up the DTV*

Overview .....	9
DTV Controls and Connectors .....	10
Basic Connections.....	12
Connecting a VCR and Cable .....	14
Connecting a VCR and Cable Box.....	15
Connecting Two VCRs for Tape Editing .....	17
Connecting a Satellite Receiver .....	18
Connecting a Satellite Receiver with a VCR .....	19
Connecting an Audio Receiver.....	20
Connecting a DVD Player with Component Video Connectors .....	21
Connecting a DVD Player with A/V Connectors.....	22
Connecting a Camcorder.....	23
Connecting a Device with an Optical IN Connector.....	24
Connecting i.LINK Compatible Devices .....	25
Using the CONTROL S Feature .....	29
Setting Up the DTV Automatically.....	30

## *Using the DTV Features*

Overview .....	31
Using the Program Guide .....	32
Using the Scrolling Index.....	33
Using Favorite Channels.....	34
Using Wide Screen Mode.....	37
Using Twin View.....	38
Using the Freeze Function .....	41
Using the i.LINK Control Panel .....	42
Using the Timer .....	43

## *Using the DTV Menus*

Overview .....	45
Using the Video Menu.....	46
Using the Audio Menu.....	48
Using the Screen Mode Menu .....	50
Using the Channel Setup Menu .....	52
Using the Parental Control Menu .....	54
Using the Setup Menu.....	58

## *Other Information*

Overview .....	61
Programming the Remote Control .....	62
Operating Other Components with Your DTV Remote Control .....	65
About i.LINK .....	67
Troubleshooting.....	68
Specifications.....	70
Index.....	71



# Introducing the Digital TV (DTV)

## Overview

This chapter gives an overview of the DTV features, defines the package contents, describes the remote control, and provides answers to frequently asked questions.

<i>Topic</i>	<i>Page</i>
Presenting the FD Trinitron Wega	1
Features	2
Package Contents	3
Using the Remote Control	3
Frequently Asked Questions	7

## Presenting the FD Trinitron Wega

The FD Trinitron Wega (pronounced VAY-GAH) is characterized by outstanding contrast, uncompromising accuracy, and corner-to-corner detail.

You'll recognize the superiority of Wega technology almost immediately. The first thing you'll notice is minimal glare from the flat picture tube. This flat-screen technology improves picture detail without distortion, unlike conventional curved screens. The FD Trinitron delivers outstanding image detail not only at the screen center, but also at the corners — so you can enjoy a bright, clear picture from any location in a room.

### About the Unit's High Glossy Finish

The unit surface is finished with high glossy paint. Due to the nature of this finish the following precautions must be observed to avoid discoloration, distortion and scratch marks:

- ❑ Do not bang the TV with any items or objects.
- ❑ Do not place any hot coffee cups and/or heavy items, such as a vase, on top of the TV. (Any water seepage may cause fire or electric shock.)

## Features

Some of the features that you will enjoy with your new DTV include:

- ❑ **Built-in Digital Television (DTV) Receiver:** You can watch digital television programs and enjoy the improved audio/video quality that these programs offer.
- ❑ **Wide Screen Mode:** Watch conventional 4:3 aspect ratio broadcasts in wide screen (16:9) mode.
- ❑ **DRC (Digital Reality Creation):** Unlike conventional line doublers, the DRC feature doubles vertical and horizontal lines, resulting in four times the density for quality sources such as DVD, satellite, and digital camcorder.
- ❑ **Twin View™:** Using the Multi-Image Driver (MIDX), Twin View allows you to watch two programs side by side, with the ability to zoom in one picture. You can watch pictures from two different sources (1080i, 720p, 480p, and 480i) simultaneously.
- ❑ **Program Guide:** Lets you select digital channels and subchannels and review program information from an on-screen list.
- ❑ **Scrolling Index:** Lets you preview and select programs from a scrolling index of video pictures.
- ❑ **Favorite Channels:** Allows you to preview and select from 16 of your favorite channels.
- ❑ **Velocity Modulation:** Vertical line enhancement that sharpens picture definition.
- ❑ **Steady Sound:** Equalizes volume levels so there is consistent output between programs and commercials.
- ❑ **Parental Control:** V-Chip technology allows parents to block unsuitable programming for younger viewers.
- ❑ **Component Video Inputs:** Offers the best video quality for DVD (480p, 480i), and digital set-top box (HD1080i, 720p) connections.
- ❑ **S-VIDEO Inputs:** Provides a high-quality video signal from connected equipment.
- ❑ **CineMotion™:** Provides optimal picture quality for film-based sources (media originally shot in 24 frames-per-second format).
- ❑ **i.LINK:** Provides a secure digital interface to other digital home entertainment devices, including digital cable set-top boxes. i.LINK allows for the secure transfer of copyright-protected high-definition content between these devices and your digital television.



## Package Contents

Along with your new digital TV, the package contains a remote control and two AA batteries. No additional cables are included. These items are all you need to set up and operate the DTV in its basic configuration.

Most components (VCRs, DVD players, etc.) come with the necessary cables to connect them. If you want to set up a complex system, you may need to buy extra cables, connectors, etc. Be sure to have these on hand before you start to connect your system.

## Using the Remote Control

Although some of the DTV's functionality can be controlled using buttons located on the front panel of the DTV (see page 10), you'll find the remote control to be more convenient while watching TV.

---

### Inserting Batteries

Insert two size AA (R6) batteries (supplied) by matching the + and - on the batteries to the diagram inside the battery compartment.

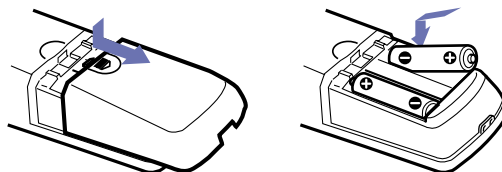

Remove the batteries to avoid damage from possible battery leakage whenever you anticipate that the remote control will not be used for an extended period. Handle the remote control with care; avoid dropping it, getting it wet, placing it in direct sunlight, near a heater, or where the humidity is high.

**Button Descriptions**

The following table describes the buttons on the remote control's outside and inside panels.

**Outside Panel**

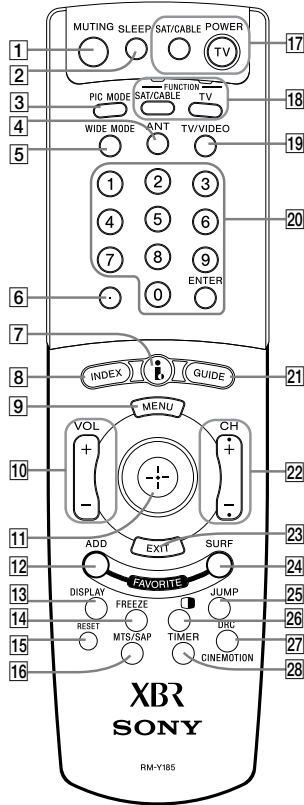

Button	Description
1 MUTING	Press to mute the sound. Press again or press VOL+ to restore the sound.
2 SLEEP	Press repeatedly until the DTV displays the time in minutes (15, 30, 45, 60, or 90) that you want the DTV to remain on before shutting off automatically. Cancel by pressing until Sleep Off appears. While the Sleep feature is set, press once to view remaining time.
3 PIC MODE	Press repeatedly to step through the video picture modes: Vivid, Standard, Movie, Game, Pro. Also available in the Video menu. For details, see page 46.
4 ANT	Press to change between the VHF/UHF input and the CABLE input.
5 WIDE MODE	Press repeatedly to step through the Wide Mode settings: Wide Zoom, Normal, Full, Zoom. Also available in the Screen Mode menu. For details, see pages 37 and 50.
6	Use with 0 – 9 and ENTER buttons to select subchannels (for example, 2.1). For details on selecting subchannels, see page 32.
7	Press to display the i.LINK Control Panel. There is also an i.LINK button on the front panel of the DTV (see page 10). For details on using the i.LINK Control Panel, see page 42.
8 INDEX	Press to display the Scrolling Index. For details, see page 33.
9 MENU	Press to display the DTV on-screen menu. Press again to exit from the menus. For details, see page 45.
10 VOL	Press to adjust the volume.
11	Move the joystick     to move the on-screen cursor. To select an item, press the center of the joystick ().
12 ADD FAVORITE	Press to add the current channel to the Favorite Channels list. For details, see page 34.
13 DISPLAY	Press once to display the channel number, channel label (if set), time, and other information. Press again to turn Display off.
14 FREEZE	Press to freeze the window picture. Press again to restore the picture. For details, see page 41.
15 RESET	Press while a menu is displayed (pages 45 to 60) to reset the settings to the factory defaults. Also used to clear Favorite Channels (see page 36).

<b>Button</b>	<b>Description</b>
<b>16</b> MTS/SAP	Press repeatedly to step through the Multi-channel TV Sound (MTS) options: Stereo, Auto SAP, and Mono. Also available in the Audio menu. For details, see page 49.
<b>17</b> POWER buttons (GREEN)	Press to turn on and off the DTV and other audio/video equipment you have programmed into the remote control. For instructions, see "Programming the Remote Control" on page 62.
<b>18</b> FUNCTION buttons	Press to select the equipment (SAT/CABLE or TV) that you want to operate. The indicator lights up momentarily when pushed to show which device the remote control is operating.
<b>19</b> TV/VIDEO	Press repeatedly to step through the video equipment connected to your DTV's video inputs.
<b>20</b> 0 – 9 and ENTER	Press 0 - 9 to select a channel — the channel changes after 2 seconds. Press ENTER to select immediately.
<b>21</b> GUIDE	Press to display the program guide. For details, see page 32.
<b>22</b> CH	Press to scan through channels. To scan rapidly through channels, press and hold down either CH button.
<b>23</b> EXIT	Press to exit the on-screen menu or display and return to normal viewing.
<b>24</b> SURF FAVORITE	Press to display the Favorite Channels list. For details, see page 35.
<b>25</b> JUMP	Press to jump back and forth between two channels. The DTV alternates between the current channel and the last channel that was selected.
<b>26</b> 	Press to turn on and off Twin View. For details, see pages 38 to 40.
<b>27</b> DRC CINEMOTION	Press repeatedly to step through the available high-resolution picture modes: Interlaced, Progressive and CineMotion. Also available in the Video menu. For details, see page 47.
<b>28</b> TIMER	Press to program the DTV to turn on and off and tune to a specific channel at two scheduled viewing times (see page 43). Also available in the Setup menu (see page 60).

## Introducing the Digital TV (DTV)

### Inside Panel

You can access the following buttons by lifting up the outside panel.

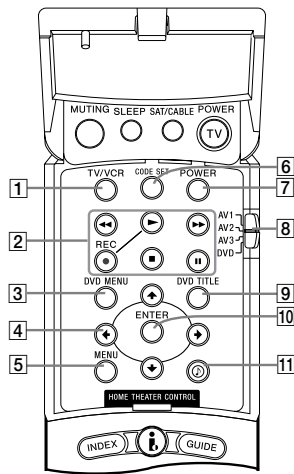

Button	Description
1 TV/VCR	Press to change the VHF/UHF output of the VCR.
2 Transport Buttons	<ul style="list-style-type: none"> <li>◀◀ Rewind</li> <li>▶▶ Play</li> <li>● Record (press together with ▶▶)</li> <li>■ Stop</li> <li>▶▶ Fast-forward</li> <li>   Pause</li> </ul>
3 DVD MENU	Press to display the DVD menu.
4 ◀▶↕	Press ◀▶↕ to move the on-screen cursor.
5 MENU	Press to display the DVD setup menu.
6 CODE SET	Used for programming the remote control to operate non-Sony video equipment. For details, see "Programming the Remote Control" on page 62.
7 POWER	Press to turn on and off other audio/video equipment you have programmed into the remote control. For instructions, see "Programming the Remote Control" on page 62.
8 AV1 AV2 AV3 DVD	Use to switch control for connected video equipment. You can program one video source for each switch position. For details, see "Programming the Remote Control" on page 62.
9 DVD TITLE	Press to display the DVD title.
10 ENTER	Press to select.
11	Press repeatedly to step through the Audio Effect options: TruSurround, Simulated, and Off. Also available in the Audio menu. For details, see page 48.

## Frequently Asked Questions

---

### *What is digital TV (DTV)?*

*Digital television* (or “DTV”) refers to the over-the-air television broadcast standards adopted by the Federal Communications Commission in 1996. Developed by the Advanced Television Systems Committee (ATSC), a group of manufacturing companies, these standards define the specifications for 18 digital broadcast formats.

There are six formats in the ATSC DTV standard that are described as “High Definition Television.” The remaining 12 video formats are described as “Standard Definition Television.”

Although the technical aspects of these standards are transparent to television viewers, the benefits are as dramatic as those experienced when digital music on compact disk was introduced — probably even more so.

Your Sony DTV is capable of receiving all 18 formats of digital TV formats, including high-definition.

---

### *What are the benefits of DTV?*

For the television viewer, digital TV represents one of the most significant advances in television since color television replaced black and white. Here are just a few of the benefits:

- ❑ Dramatically superior picture quality, with up to six times the picture detail of today’s analog television.
- ❑ Multichannel digital sound, including Dolby® Digital sound.
- ❑ Widescreen. DTV can provide the same type of widescreen presentation as you see in movie theaters. The new screen size has a 16:9 width-to-height (or “aspect”) ratio, compared with a 4:3 aspect ratio of today’s conventional television. This means that digital broadcasts of movies no longer need to be “reformatted” for television.

---

### *Do I need a special antenna to receive digital television?*

No. Initially, digital television will arrive through a standard, over-the-air VHF/UHF antenna, which means you can receive digital broadcasts using the same terrestrial (“rooftop”) antenna you currently use to receive conventional programming. However, if you currently receive your VHF/UHF programming via cable, you will need to install a VHF/UHF antenna in order to receive digital programming. Your Sony DTV, however, is also equipped with connectors that may allow you to connect DTV-compatible cable boxes when they become available.

---

*Introducing the Digital TV (DTV)*

---

*Can this TV receive conventional analog broadcasts that are available today?*

Yes. This TV is designed to receive conventional analog broadcasts, cable TV, as well as all formats of digital broadcasts. Of course, you can also connect VCRs, DVD players, digital broadcast (satellite) receivers, and other audio/video components.

---

*When is digital broadcasting being introduced?*

The transition from today's analog broadcasting system to digital television will take time to complete. In the fall of 1998, some networks started to broadcast digital programs.

---

*How can I select digital channels?*

Digital channels are indicated by the use of a decimal or "dot" in the subchannel number (for example, "2.1"). This number appears when you press the CH +/- buttons or press the DISPLAY button. To select a subchannel directly, use the 0-9 buttons,  $\odot$  button, and the ENTER button.

**For example, to select subchannel 2.1, press:**

$\textcircled{2} + \odot + \textcircled{1} + \text{ENTER}$

You can also select digital channels using an on-screen program guide. See page 32 for details.

# Connecting and Setting Up the DTV

## Overview

This chapter includes illustrated instructions for setting up your DTV.

<i>Topic</i>	<i>Page</i>
Basic Connections	12
Connecting a VCR and Cable	14
Connecting a VCR and Cable Box	15
Connecting Two VCRs for Tape Editing	17
Connecting a Satellite Receiver	18
Connecting a Satellite Receiver with a VCR	19
Connecting an Audio Receiver	20
Connecting a DVD Player with Component Video Connectors	21
Connecting a DVD Player with A/V Connectors	22
Connecting a Camcorder	23
Connecting a Device with an Optical IN Connector	24
Connecting i.LINK Compatible Devices	25
Using the CONTROL S Feature	29
Setting Up the DTV Automatically	30

### Note About the AC Power Cord

The AC power cord is attached to the rear of the DTV with a hook. Use caution when removing the AC plug from its holder. Gently slide the plug in the upward direction to remove from hook. Once removed, the AC power plug should automatically disengage from its stored location.

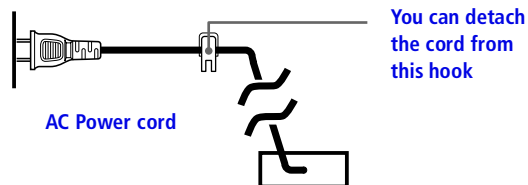

## DTV Controls and Connectors

### Front Panel Controls

The front panel provides convenient inputs for audio/video components you plan to connect temporarily, such as a camcorder or digital camera. It includes several buttons that you'll also find on the remote control.

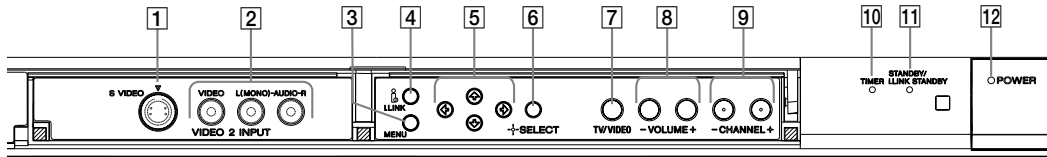

Control	Description
1 S VIDEO 2 INPUT	Connects to the S VIDEO OUT jack of your camcorder or other S VIDEO-equipped video component. Provides better picture quality than the VHF/UHF jacks or the Video IN jack.
2 VIDEO 2 INPUT VIDEO/L(MONO)-AUDIO-R	Connect to the audio and video OUT jacks on your camcorder or other video component.
3 MENU	Press to display the DTV on-screen menu. Press again to exit from the menus. For details, see page 45.
4 i.LINK	Press to display the i.LINK Control Panel. For details on using the i.LINK Control Panel, see page 42.
5 ←→↑↓	Press ←→↑↓ to move the on-screen cursor and press SELECT to select.
6 + SELECT	Press to select the on-screen highlighted item.
7 TV/VIDEO	Press repeatedly to step through the video equipment connected to your DTV's video inputs.
8 -VOLUME+	Press to adjust the volume.
9 -CHANNEL+	Press to scan through channels.
10 TIMER	When lit, indicates one of the timers is set. For details, see page 43.
11 STANDBY/ i.LINK STANDBY	When lit in orange, indicates that i.LINK Standby is On. When lit in red, indicates that i.LINK Standby is Off. For details, see page 59.
12 POWER	Press to turn on and off the DTV.



DTV Rear Panel

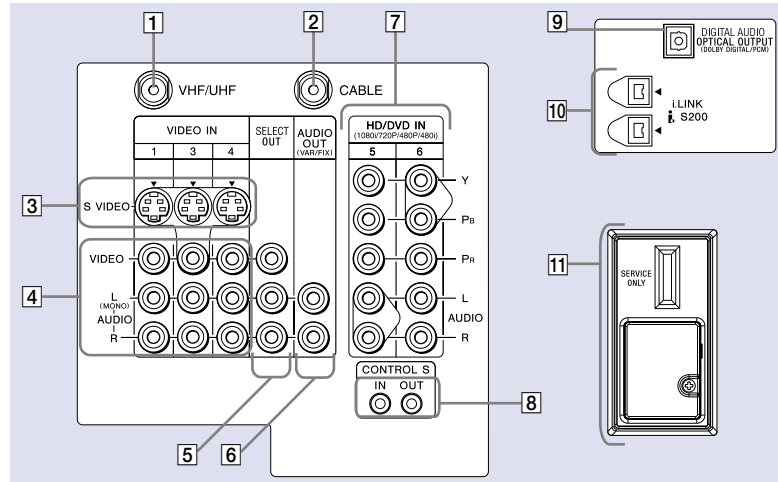

Connection	Description
1 VHF/UHF	Connects to your VHF/UHF antenna.
2 CABLE	Connects to your cable source.
3 S VIDEO IN 1/3/4	Connects to the S VIDEO OUT jack of your VCR or other S VIDEO-equipped video component. Provides better picture quality than the VHF/UHF jacks or the Video IN jack.
4 VIDEO IN 1/3/4 VIDEO/L(MONO)-AUDIO-R	Connect to the audio and video OUT jacks on your VCR or other video component. A 6th video input (VIDEO 2) is located on the front panel of the DTV. The Audio and Video IN jacks provide better picture quality than the VHF/UHF IN jack.
5 SELECT OUT	Connect to the audio and video IN jacks on your VCR or other video component. The output signal is determined by the SELECT OUT setting in the Setup menu (see page 58).
6 AUDIO OUT (VAR/FIX) L(MONO)-AUDIO-R	Connect to the left and right audio inputs of your audio or video component.
7 HD/DVD IN (1080i/720p/480p/480i) VIDEO IN 5/6	Connect to your DVD player's or digital set-top box's component video (Y, PB, PR) and audio (L/R) jacks.
8 CONTROL S IN/OUT	Allows the DTV to receive (IN) and send (OUT) remote control signals to other Sony infrared-controlled audio or video components.
9 DIGITAL AUDIO OPTICAL OUTPUT (DOLBY DIGITAL/PCM)	Connect to the optical audio input of an audio component that is Dolby Digital and PCM compatible.
10 i.LINK S200	Used for connecting i.LINK equipped devices.
11 Service Only	For Sony service use only.

## Basic Connections

This section describes how to connect a VHF/UHF antenna, CATV cable, and CATV cable box.

### Connecting a VHF/UHF Antenna

The connection you choose depends on the type of VHF/UHF antenna you have in your home.

Newer homes are usually equipped with 75-ohm coaxial cable:

#### VHF Only or VHF/UHF

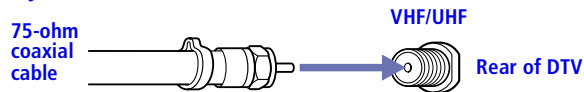

Older homes may have 300-ohm twin lead cable:

#### VHF Only or UHF Only or VHF/UHF

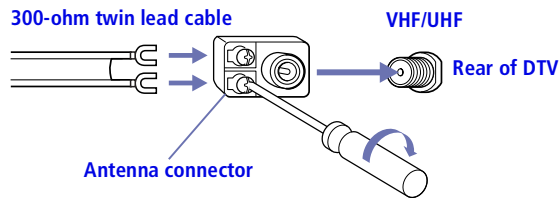

Some homes may have both 75-ohm coaxial and 300-ohm twin lead cables:

#### VHF and UHF

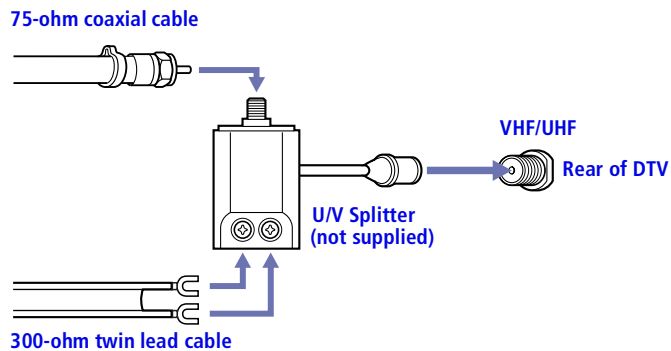

**Connecting a CATV  
Cable or a  
CATV Cable Box**

**CATV Cable**

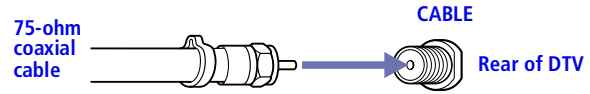

**CATV Cable Box**

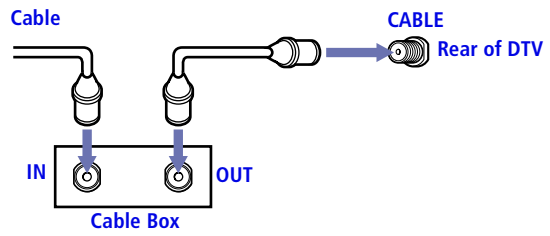

## Connecting and Setting Up the DTV

### Connecting a VCR and Cable

Use this hookup if you have cable TV that does not require a cable box.

- 1** Connect the cable TV cable to the VCR's IN jack.
- 2** Using a coaxial cable, connect the VCR's OUT jack to the DTV's CABLE jack.
- 3** Using an A/V cable, connect the VCR's Audio and Video OUT jacks to the DTV's Audio and Video IN jacks.

 If the VCR you are connecting has an S VIDEO jack, you can use an S VIDEO cable for improved picture quality (compared to a combination audio/video cable). Because an S VIDEO cable carries only the video signal, you will also need audio cables for sound.

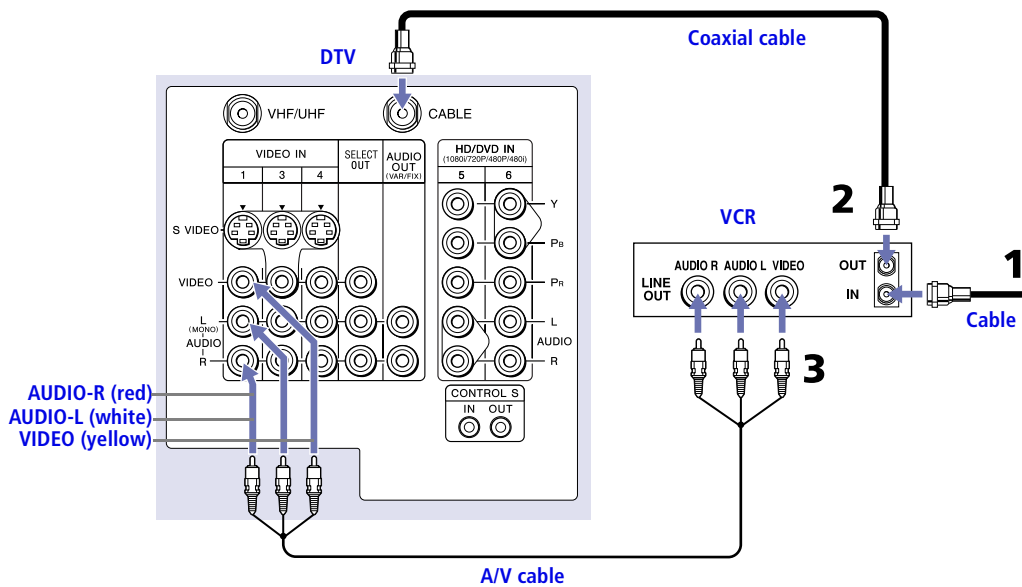

## Connecting a VCR and Cable Box

### Use this hookup if

- ❑ Your cable TV company scrambles some channels, but not all of them (pay channels vs. regular cable channels), so you need to use a cable box
- ❑ You want to use the Twin View or Scrolling Index feature.

### With this setup you can

- ❑ Use the DTV remote control to change channels using your cable box when the signal is scrambled.
- ❑ Use the DTV remote control to change channels using your DTV when the signal is not scrambled. (Your DTV's tuner provides a better signal than the cable box.)
- ❑ Use the Twin View and Scrolling Index features.
- ❑ Record both regular cable TV and scrambled channels.

### To connect a cable box and a VCR, you will need

- ❑ A small inexpensive device known as a splitter.
  - ❑ Three short coaxial cables.
  - ❑ Either a combination audio/video cable, or an S VIDEO cable and audio cables.
- 1 Connect the CATV cable to the single (input) jack of the splitter.
  - 2 Use a coaxial cable to connect one of the two output jacks of the splitter to the DTV's CABLE jack.
  - 3 Use a coaxial cable to connect the other output jack of the splitter to the input jack of the cable box.
  - 4 Use a coaxial cable to connect the output jack of the cable box to the input jack of the VCR.
  - 5 Use the video line (yellow) of a combination audio/video (A/V) cable to connect the video output jack of the VCR to the video input jack of the DTV.

 If your VCR has an S VIDEO jack, you can substitute an S VIDEO cable for the video line of an A/V cable. The S VIDEO cable will provide improved video signal quality.

- 6 Connect the left (white) and right (red) audio output jacks on the VCR to the respective input jacks on the DTV.

*(Continued on the next page)*

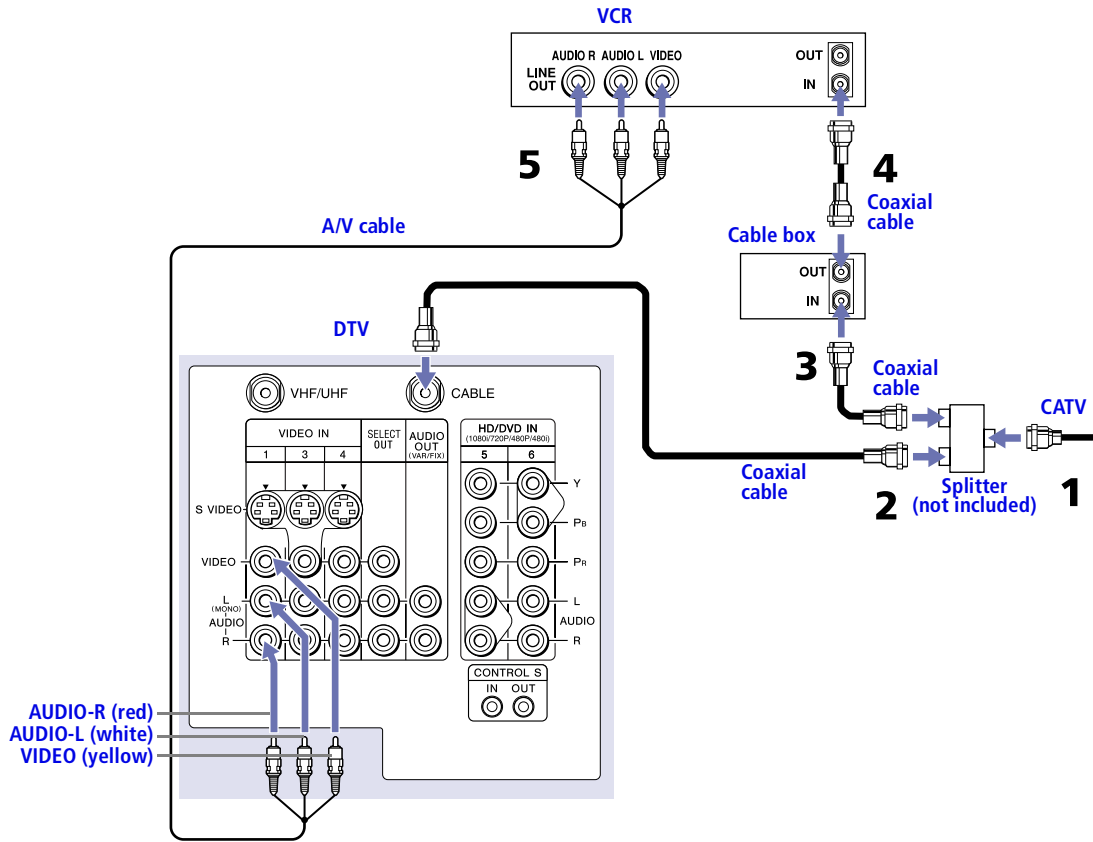

**IMPORTANT** - To use the Twin View or Scrolling Index feature or to watch premium (scrambled) channels the **VCR MUST BE TURNED ON**; otherwise, you will be unable to view them.

## Connecting Two VCRs for Tape Editing

Connecting two VCRs together, then into the DTV, allows you to switch between the two to be sure that what you are playing on one is recording on the other.

- 1 Using an A/V cable, connect the playback VCR's Audio and Video OUT jacks to the recording VCR's Audio and Video IN jacks.
- 2 Using an A/V cable, connect the recording VCR's Audio and Video OUT jacks to the DTV's Audio and Video IN jacks.

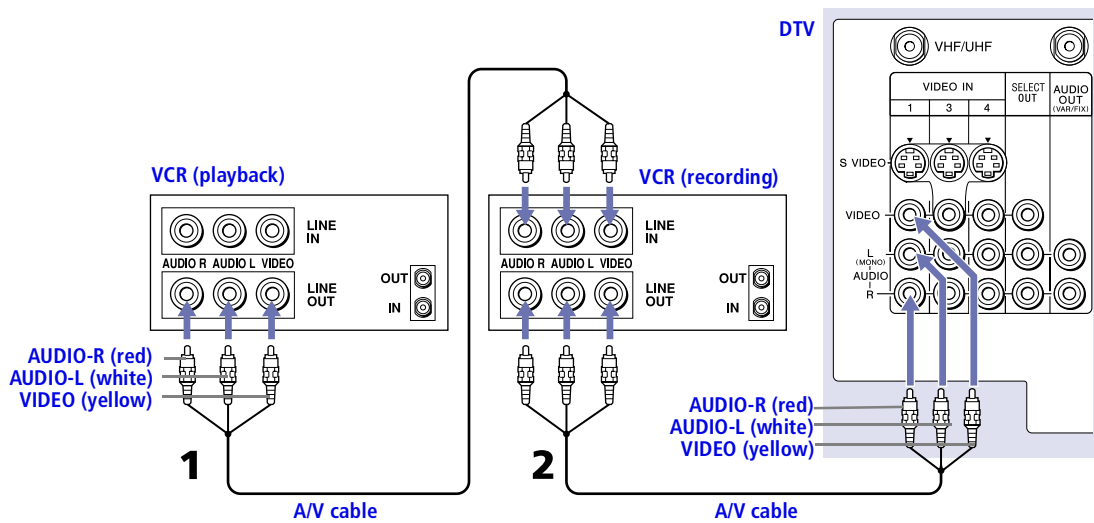

- 3 If necessary, change the video input on your VCR. (For details, see your VCR's instruction guide.)

### To do tape editing

- Set the DTV to the video input intended for playback by pressing the TV/VIDEO button on the remote control.

✍ If the VCRs you are connecting have S VIDEO jacks, you can use S VIDEO cables for improved picture quality (compared to a combination audio/video cable). Because S VIDEO cables carry only the video signal, you will also need audio cables for sound.

## Connecting a Satellite Receiver

- 1 Connect the satellite antenna cable to the satellite receiver's SATELLITE IN jack.
- 2 Using an A/V cable, connect the satellite receiver's Audio and Video OUT jacks to the DTV's Audio and Video IN jacks.
- 3 Connect a coaxial cable from your cable or antenna to the DTV's CABLE jack.

 If the receiver you are connecting has an S VIDEO jack, you can use an S VIDEO cable for improved picture quality (compared to a combination audio/video cable). Because S VIDEO cables carry only the video signal, you will also need audio cables for sound.

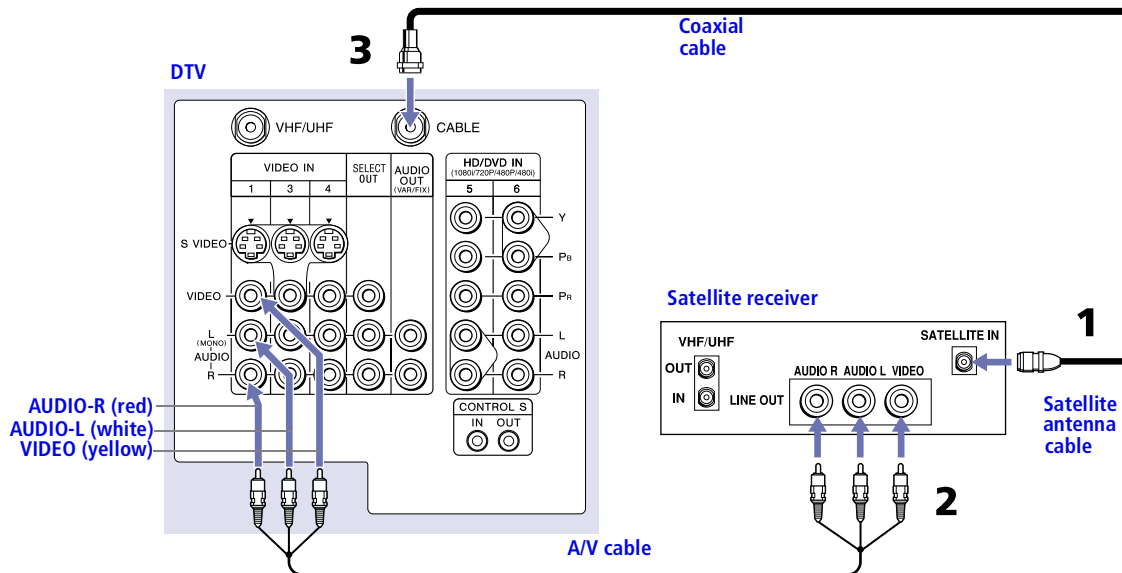



## Connecting a Satellite Receiver with a VCR

- 1 Connect the satellite antenna cable to the satellite receiver's SATELLITE IN jack.
- 2 Connect the CATV cable to the VCR's VHF/UHF IN jack.
- 3 Using a coaxial cable, connect the VCR's OUT jack to the DTV's CABLE jack.
- 4 Using an A/V cable, connect the satellite receiver's Audio and Video OUT jacks to the VCR's Audio and Video IN jacks.
- 5 Using an A/V cable, connect the VCR's Audio and Video OUT jacks to the DTV's Audio and Video IN jacks.
- 6 If necessary, change the video input on your VCR. (For details, see your VCR's instruction guide.)

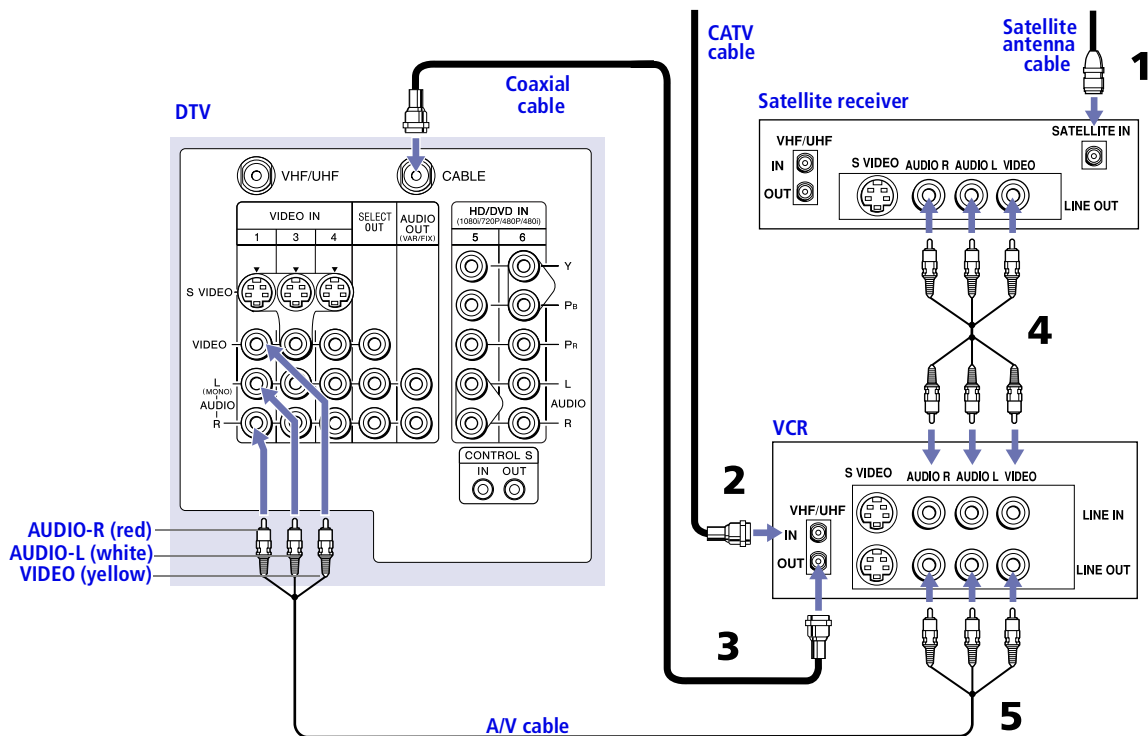

 If the peripherals you are connecting have S VIDEO jacks, you can use S VIDEO cables for improved picture quality (compared to combination audio/video cables). Because S VIDEO cables carry only the video signal, you will also need audio cables for sound.

## Connecting an Audio Receiver

For better sound quality, you may want to connect your DTV to your stereo system's audio receiver.

### To connect to an audio receiver

- Use audio cables to connect the DTV's Audio OUT jacks to the audio receiver's audio LINE IN jacks.

#### DTV

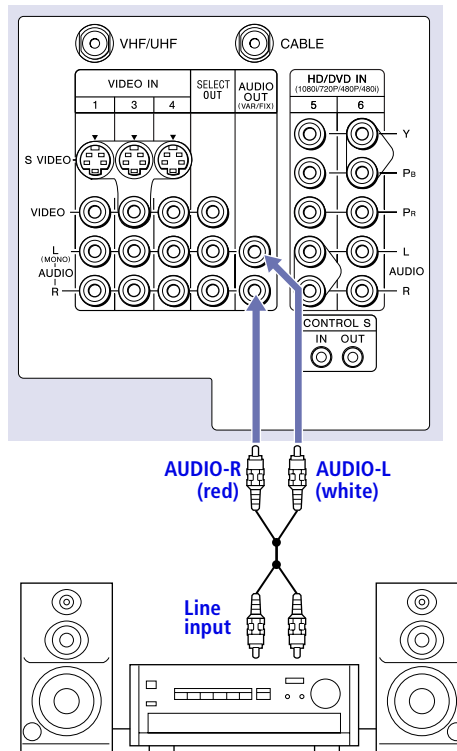

## Connecting a DVD Player with Component Video Connectors

This is the preferred hookup to use if your DVD player has component video out jacks.

- 1 Using three separate component video cables, connect the DVD player's Y, Pb and Pr jacks to the Y, Pb and Pr jacks on the DTV. Use the HD/DVD IN 5 or 6 connections.

 The Y, Pb and Pr jacks on your DVD player are sometimes labeled Y, Cb and Cr, or Y, B-Y and R-Y. If so, connect the cables to like colors.

- 2 Using an audio cable, connect the DVD player's Audio OUT jacks to the DTV's Audio IN jacks. Be sure to use the same column of inputs that you used for the video connection (HD/DVD IN 5 or 6).

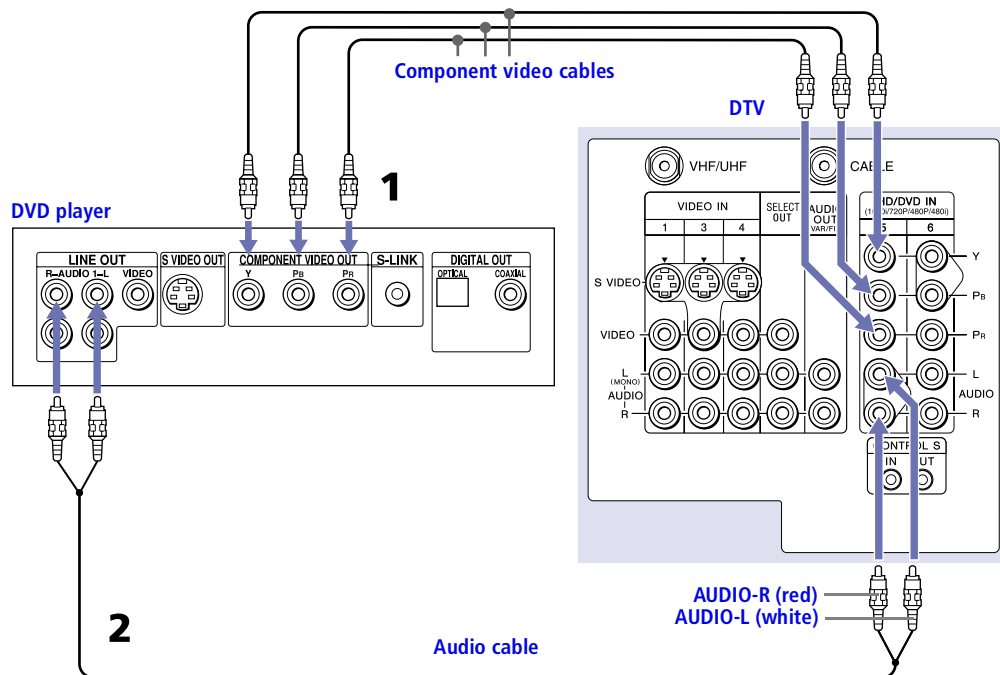

 You cannot record the signal from any equipment connected into the Y, Pb, Pr jacks.

## Connecting a DVD Player with A/V Connectors

Use this hookup if your DVD player does not have component video out jacks (as shown on page 21).

 An S VIDEO connection will give a good-quality video signal, but if your DVD player has component video, that connection (described on page 21) will give an even better signal.

- 1 Using audio cables, connect the DVD player's Audio OUT jacks to the DTV's Audio IN jacks.
- 2 Using an S VIDEO cable, connect the DVD player's S VIDEO jack to the DTV's S VIDEO jack.

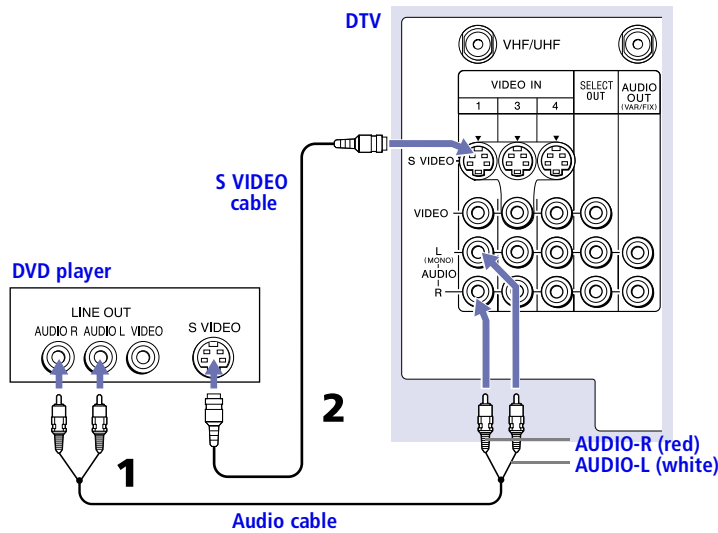

## Connecting a Camcorder

For easy connection of the camcorder, the DTV has front Audio and Video inputs (shown below). If you prefer, you can connect the camcorder to the DTV's rear Audio and Video IN jacks.

- Using A/V cables, connect the camcorder's Audio and Video OUT jacks to the DTV's Audio and Video IN jacks.

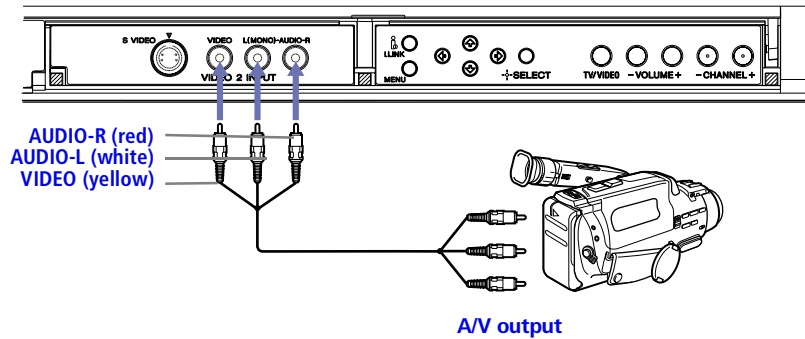

If you have a mono camcorder, connect its audio output to the DTV's AUDIO L jack.

- ✎ If the camcorder you are connecting has an S VIDEO jack, you can use an S VIDEO cable for improved picture quality (compared to a combination audio/video cable). Because S VIDEO cables carry only the video signal, you will also need audio cables for sound.

## Connecting a Device with an Optical IN Connector

You can use the DTV's DIGITAL AUDIO OPTICAL OUTPUT jack to connect an audio device that is Dolby Digital and PCM compatible, such as an audio amplifier.

- Using an optical cable, connect the device's OPTICAL IN jack to the DTV's DIGITAL AUDIO OPTICAL OUTPUT jack.

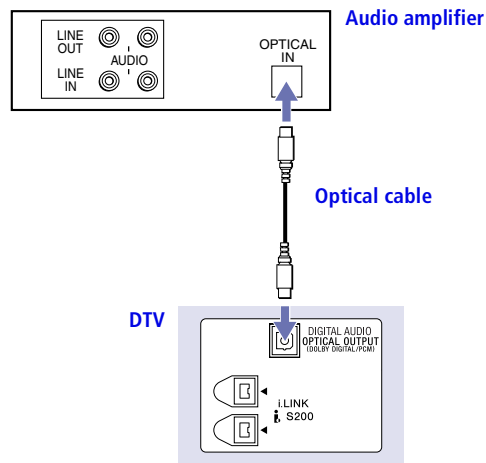

 You might also want to connect the DTV's analog audio out connectors to the amplifier's analog audio in connectors, as described on page 20.

## Connecting i.LINK Compatible Devices

This DTV is equipped with i.LINK, which provides a secure digital interface to other digital home entertainment devices, including digital cable set-top boxes. i.LINK allows for the secure transfer of copyright-protected high-definition content between these devices and your digital television.

 At the time this DTV went to market, the Sony digital cable set-top box (DHG-M55CV) is the only i.LINK device that is verified to be compatible with this DTV.

Some early versions of the Sony digital cable set-top box (DHG-M55CV) may not support an i.LINK digital connection to your DTV. If you have difficulty with the connection between your Sony digital cable set-top box (DHG-M55CV) and your DTV, contact Customer Information Service Center at 1-800-222-SONY(7669). In most cases you can continue to use your set-top box with your DTV, using an analog audio/video connection (as shown on page 26), instead of the i.LINK digital connection (also shown on page 26).

For more information about i.LINK, see "About i.LINK" on page 67.

### Using i.LINK Cables

This DTV has two 4-pin S200 i.LINK terminals. You can use any of the following i.LINK cables with the DTV:

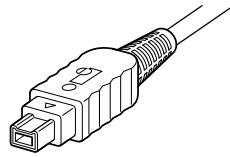

4-pin i.LINK cable

<b>Sony Model Number</b>	<b>Length</b>
VMC-IL4415	1.5 meters
VMC-IL4435	3.5 meters

 Do not use cables other than the ones listed above.

## Connecting Cables

Before connecting this unit to i.LINK-compatible equipment, see the instruction manual of the i.LINK device to be connected.

- 1 Using an A/V cable, connect the i.LINK device's Audio and Video OUT jacks to the DTV's Audio and Video IN jacks.
- 2 Using an i.LINK cable (see page 25), connect the device's i.LINK jack to either of the DTV's i.LINK jacks.

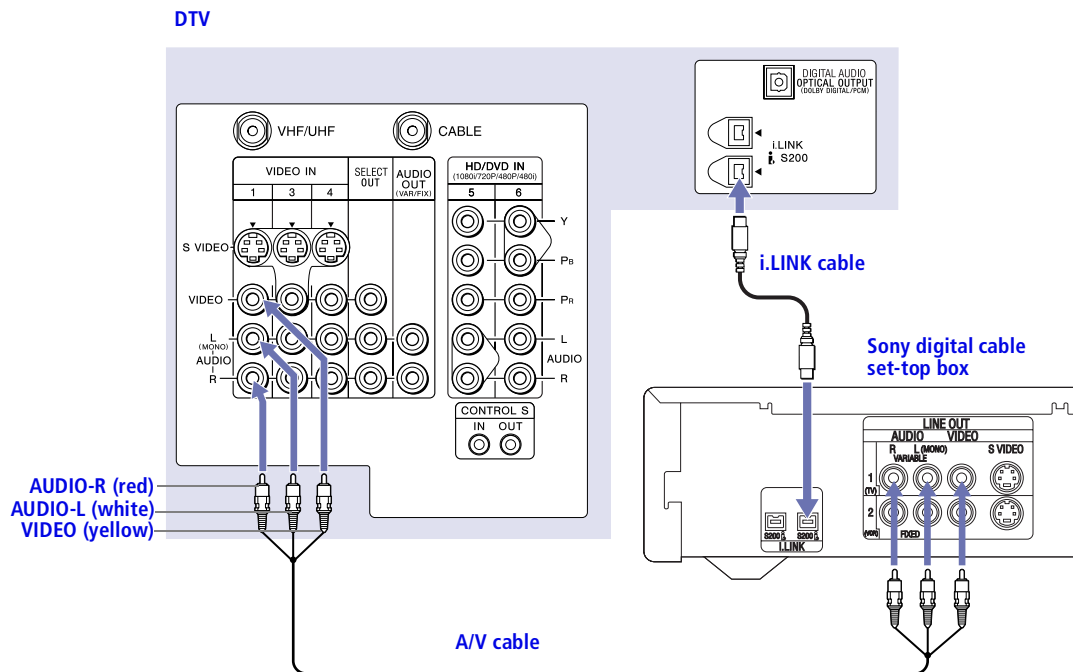

i.LINK devices can be "hotplugged" (connected and disconnected while they are still powered on). The DTV automatically recognizes the device and displays the screen shown on page e28.



**Notes on Connecting  
i.LINK Devices**

- To connect two or more i.LINK-capable devices, use i.LINK cables to connect them as shown below.

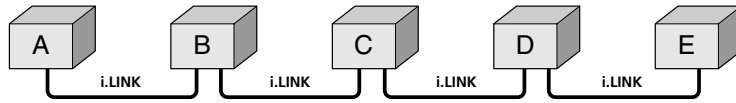

- You can connect up to 63 i.LINK devices. However, the maximum number of cables in any serial route is 16.

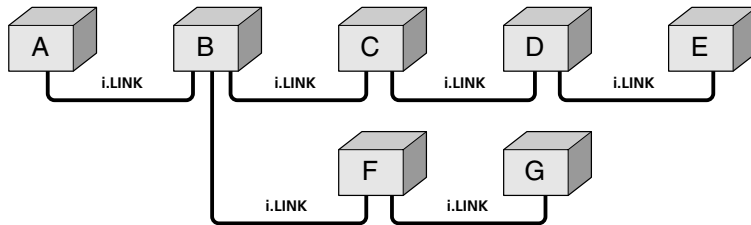

- Do not connect i.LINK devices in a way that creates a loop.

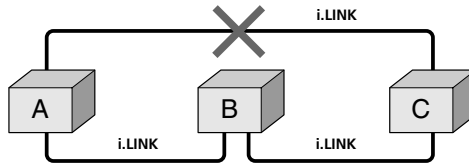

- Connecting non-compatible devices, such as PCs or PC peripherals, may result in malfunctions.

## Completing i.LINK Setup

Before you can use an i.LINK device with the DTV, you need to register the device as follows.

- 1 After you've connected the cables (as described on page 26), first turn on the DTV, and then turn on the i.LINK device(s). The following screen automatically appears.



To add the i.LINK device, highlight Add and press  $\oplus$ .

 If you select Cancel, the i.LINK device is set up as "hidden" and it does not appear in the i.LINK Control Panel. To see the device in the i.LINK Control Panel, change the i.LINK Setup option from Hide to Show in the Setup menu (see page 59).

- 2 If you selected Add in step 1, and the device requires an analog video connection, the following screen appears.

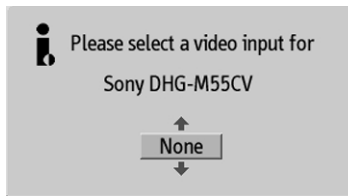

 Depending on the i.LINK device you are setting up, this screen may not be displayed. In this case, the device's video input will be displayed as N/A.

- 3 Move the joystick  $\uparrow$  and  $\downarrow$  to highlight the video input (VIDEO 1-4) that connects the i.LINK device to the DTV. If you don't need an analog video connection, select None. Then press  $\oplus$ .

A confirmation screen appears, which indicates the i.LINK device name and video input. The device is now available in the i.LINK Control Panel (see page 42).

### For more information

- To change the setup of the i.LINK device, use the Setup menu. For details, see page 59.
- For information on using the i.LINK Control Panel, see page 42.
- For general information about i.LINK, see page e67.

## Using the CONTROL S Feature

CONTROL S allows you to control your system and other Sony equipment with one remote control. In addition to allowing you to control multiple devices with one remote control, the CONTROL S feature allows you to always point your remote control at your DTV, instead of having to point it at the other equipment, which might be hidden or out of direct line of sight.

Use CONTROL S IN to send signals to the DTV.

Use CONTROL S OUT to send signals to connected equipment.

### DTV

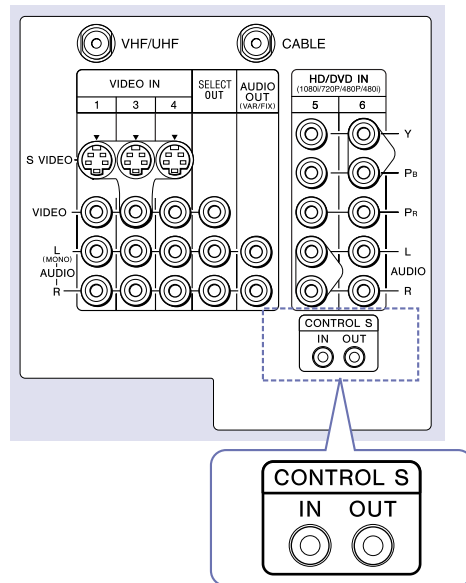

## Setting Up the DTV Automatically

 The initial setup screens appear only after turning on the DTV the first time, or after selecting Factory Reset in the Setup menu (page e58).

If you need to set the clock at a later time, press the TIMER button on the remote control (see page 43).

You can also run Auto Program at any time from the Channel Setup menu (see page 52).









 You can run the demonstration again by selecting Demo from the Setup menu (see pages 58 to 60).

The first time you turn on the DTV, a series of screens guide you through the initial setup of the DTV. During this setup, you are prompted to set the clock and start Auto Program, which searches for and stores a list of analog and digital channels you are receiving for VHF/UHF and CABLE inputs.



 Be sure to complete all connections before turning on the DTV the first time.

- 1 Press POWER to turn on the DTV and display the Welcome screen.



- 2 Press  to continue Setup. The set clock screen appears.
- 3 Move the joystick  and  to set the current day and time (hour, minute, and AM/PM). Press  or move the joystick  to confirm each setting and move to the next setting. Move the joystick  to go back to the previous setting.
- 4 After you've set the clock, move the joystick  to highlight Next and press  to continue Setup. The Auto Program screen appears.
- 5 To start Auto Program, press  to select Auto Program. The DTV automatically creates a channel list of analog and digital channels. (This may take a few minutes.)
- 6 When the channel list is complete, a Congratulations screen appears.

To see a short demonstration of the features of the DTV, press  to select Demo. A self-running introduction to the features of the DTV begins. To exit the demo at any time, press any button on the remote control (or front panel).

To skip the demo and exit Setup, move the joystick  to highlight Done and press .

# Using the DTV Features

## Overview

This chapter describes how to use features of your DTV.





<i>Topic</i>	<i>Page</i>
Using the Program Guide	32
Using the Scrolling Index	33
Using Favorite Channels	34
Using Wide Screen Mode	37
Using Twin View	38
Using the Freeze Function	41
Using the i.LINK Control Panel	42
Using the Timer	43

## Using the Program Guide

The Program Guide lets you select digital channels and subchannels and review program information from an on-screen list. Subchannels are additional channels of programming broadcast simultaneously. For example, channel 4 might include six subchannels (4.1, 4.2, 4.3, 4.4, 4.5) that are showing programs at the same time.

 Analog channels are not available in the Guide.

 The Guide is not available while using any of the multipicture functions, such as Twin View, Freeze, Scrolling Index, or Favorites.

 As an alternative to using the Guide you can select subchannels directly using the 0-9 buttons and the  button on the remote control. For example, to select channel 4.1, press  +  +  and then ENTER.

### 1 Press GUIDE.

The Program Guide appears, with the currently selected program showing in the background.

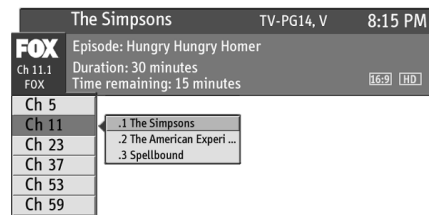

 Program information in the Program Guide is provided by the broadcasters. As a result, the Program Guide may sometimes include only the channel number without a program title or description.

### 2 Move the joystick and to highlight the channel you want to watch. The program on that channel appears in the background.

### 3 To remove the Program Guide and watch the highlighted channel, press .

#### To exit the Program Guide without changing the channel

-  Press EXIT or GUIDE.

## Using the Scrolling Index

The Scrolling Index lets you select programs from a scrolling index of video pictures.

- 1 Press INDEX.

The Scrolling Index appears, with the currently selected program in the main (left) window, and four scrolling video pictures in the right.



As each picture on the right scrolls to the live preview window, it changes briefly from a frozen video picture to a live video. The right side continues to scroll through the entire channel list.

- 2 To change the direction of the scrolling, move the joystick **▲** or **▼**.
- 3 To change the speed of the scrolling, move and hold the joystick **▲** or **▼**.
- 4 To change a frozen video picture to a live video, move the joystick **▲** or **▼** to highlight the picture, then press **⊕**.
- 5 To move the live video (from step 4) from the right to the main (left) window of the Scrolling Index, press **⊕** again.

### To exit the Scrolling Index

- Press EXIT or INDEX.

## Using Favorite Channels

You can store up to 16 of your favorite channels in the Favorite Channels list. You can use the Surf Favorites feature to preview and select channels directly from the list. You can also edit the Favorite Channels list to change the channels that are included in the list.

---

### Adding Favorite Channels

- 1 Tune to the channel you want to save to the Favorite Channels list and press **ADD**.

A message appears, indicating that the channel was stored in the Favorite Channels list.

- 2 To add more channels (to a total of 16), repeat step 1.

#### **If you try to add more than 16 channels to the Favorite Channels list**

A message appears, indicating that the Favorite Channels list is full. To change the Favorite Channels list, select **Edit** (then see “Editing the Favorite Channels List” on page 36). Or to cancel storing the channel, select **Cancel**.

#### **If you try to add a digital subchannel to the Favorite Channels list**

Only the major channel number is saved as a Favorite Channel. For example, if you are watching channel 51.4 and you press **ADD**, only channel 51 is saved as a Favorite Channel. Then, when you surf to Favorite Channel 51, the DTV tunes to channel 51 or the first available digital subchannel it finds (channel 51.1, 51.2, etc).





## Surfing the Favorite Channels List

 The letter "C" indicates that the Favorite Channel is a cable channel.



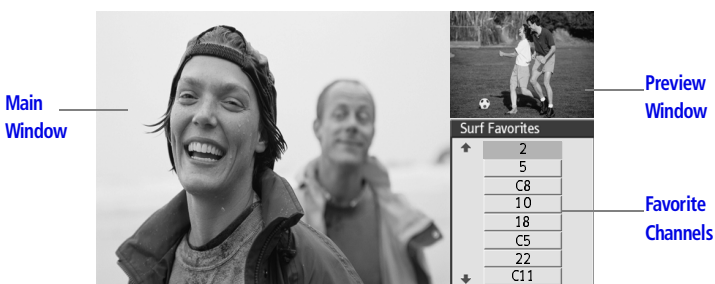

- 1 Press SURE.

The Surf Favorites screen appears, with the currently selected program in the main (left) window.



- 2 To see a preview of a program on your Favorite Channels, move the joystick  or  through the Surf Favorites list. A preview of the highlighted channel, when available, appears in the preview window.

 Digital channels are displayed as a black box in the preview window.

If more than eight Favorite Channels are set, indicated by scroll arrows ( ) , move the joystick  or  to see the additional Favorite Channels.

- 3 To remove the Surf Favorites list and watch the highlighted channel, press .



### To exit the Surf Favorites list without changing the channel

- Press EXIT or SURE.

## Using the DTV Features

### Editing the Favorite Channels List



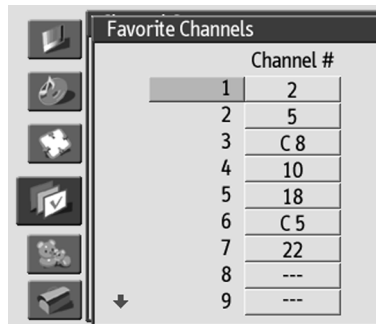

 The letter "C" indicates that the Favorite Channel is a cable channel.

- 1 Press MENU.
- 2 Move the joystick to highlight the Channel Setup icon  and press .
- 3 Move the joystick to highlight Favorite Channels and press .

The Favorite Channels list appears.



If more than nine Favorite Channels are set, move the joystick  or  to see the other Favorite Channels.

- 4 To select a Favorite (1-16) to edit, move the joystick  or  to highlight the number and press .
- 5 Move the joystick  or  to scroll through the channel list. A preview of the highlighted channel, when available, appears in the preview window.

 Digital channels are displayed as a black box in the preview window.

- 6 To set the channel to the Favorite Channel list, press .

#### To set additional channels (to a total of 16)

- Repeat steps 4 to 6.

#### To clear a Favorite Channel from the list

- After step 4, press the RESET button on the remote control.

#### To exit the Edit Favorites list

- Press EXIT.

## Using Wide Screen Mode

Wide Screen mode lets you watch 4:3 normal broadcasts in several Wide Screen modes (16:9 aspect ratio).

 You can also access the Wide Mode settings in the Screen Mode menu. For details, see page 50.

- Press WIDE MODE repeatedly to toggle through the following Wide Mode settings.



Wide Zoom

Wide Zoom enlarges the 4:3 picture, while the upper and lower parts of the picture are condensed to fit the 16:9 screen.



Normal

Normal returns the 4:3 picture to its original size.



Full

Full Mode stretches the 4:3 picture horizontally only, to fill the 16:9 screen.



Zoom

Zoom Mode enlarges the 4:3 picture horizontally and vertically to an equal aspect ratio that fills the 16:9 screen. Useful for watching Letterbox movies.

 When you change channels or inputs, the Wide Mode settings revert to Wide Zoom (or the 4:3 Default setting in the Screen Mode menu). To retain the current Wide Mode setting as channels and inputs are changed, set 4:3 Default to Off. For details, see page 50.

## Using Twin View

Twin View lets you see two pictures from two sources — from an antenna, VCR, DVD, etc., — on the screen at the same time. (You hear the sound from only one of the sources at a time. You choose which source's sound is selected.) You can change the relative size of each of the pictures.



### Displaying Twin Pictures

- 1 Tune the DTV to a working channel.
- 2 Press .

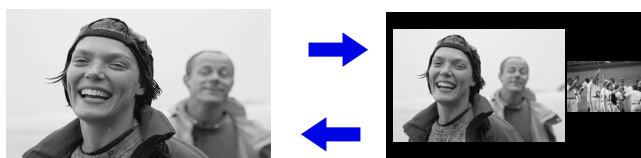
A second picture-window appears.



**To cancel twin pictures and watch the active picture**

- Press  or .

---

## Activating the Picture

With Twin View, the picture highlighted in blue is active. In the active picture, you can:

- ❑ Change channels.
- ❑ Adjust the volume.
- ❑ Switch the input sources (to go from UHF/VHF to cable, for example, press ANT or TV/VIDEO on the remote control).
- ❑ Change the picture size by moving the joystick **▲** or **▼**.

### To activate the right picture

- ❑ Move the joystick **➡**.

### To activate the left picture

- ❑ Move the joystick **➡**.

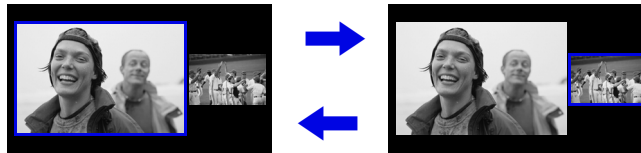

### Factors affecting Twin View

- ❑ If you use a cable box to view all channels, the same channel appears in both windows of Twin View because the cable box unscrambles only one channel at a time.
- ❑ If you use a cable box, you can view the cable box output in one Twin View window and view a signal from a different source (such as a VCR or DVD player) in the second window.
- ❑ Digital channels and equipment connected to VIDEO 5 or VIDEO 6 inputs display in the left Twin View window, but not the right.
- ❑ If you are viewing a 4:3 source and a 16:9 enhanced source (such as a DVD) side by side in Twin View, the 4:3 source will appear larger.
- ❑ Twin View is not available while viewing i.LINK devices.

### Changing the Picture Size

The zoom feature lets you vary the relative size of the left and right pictures.

- 1 Activate the picture whose size you want to change.
- 2 Move the joystick  $\blacktriangle$  to enlarge the picture.
- 3 Move the joystick  $\blacktriangledown$  to make the picture smaller.



When you adjust the twin screen sizes, the DTV memorizes the change. The next time you use the Twin View function, the memorized sizes appear.

## Using the Freeze Function

The FREEZE button allows you to temporarily capture a program's picture. You can use this feature to write down information such as phone numbers, recipes, etc.

 The Freeze feature is not available while using Twin View.

- 1 When the program information you want to capture is displayed, press the FREEZE button.
- 2 The DTV switches to Twin View mode and displays the "frozen" picture on the right, while the current program continues on the left.



- 3 To cancel and return to normal viewing, press the FREEZE or EXIT button.



## Using the DTV Features

### Using the i.LINK Control Panel

The i.LINK Control Panel lets you see a list of i.LINK devices that are connected to and communicating with the DTV.

 At the time this DTV went to market, the Sony digital cable set-top box (DHG-M55CV) is the only i.LINK device that is verified to be compatible with this DTV.

Some early versions of the Sony digital cable set-top box (DHG-M55CV) may not support an i.LINK digital connection to your DTV. If you have difficulty with the connection between your Sony digital cable set-top box (DHG-M55CV) and your DTV, contact Customer Information Service Center at 1-800-222-SONY(7669). In most cases you can continue to use your set-top box with your DTV, using an analog audio/video connection (as shown on page 26), instead of the i.LINK digital connection (also shown on page 26).

 You can also access the i.LINK Control Panel using the  button on the DTV's front panel. For details, see page 10.

- 1 To display the i.LINK Control Panel, press the  button.



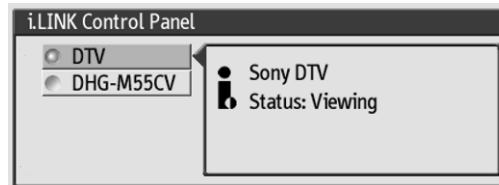

The i.LINK Control Panel appears, which displays a list of i.LINK devices that are set to Show in the i.LINK Setup menu (page 59).



 If the i.LINK device is not listed in the i.LINK Control Panel, you need to change the i.LINK Setup option from Hide to Show (see page 59).

DTV is always the first device listed. If other i.LINK devices are connected, they are listed according to their manufacturer's model name. If there are duplicate models connected, they are also designated a number (1,2,3, etc.). If a device is unknown, it is listed as "Device."

If no i.LINK devices are connected to the DTV, the message "There are no i.LINK devices available" is displayed.

- 2 To check the status of an i.LINK device, move the joystick  or  to highlight the device name. The background continues to display the video of the device that is selected.
- 3 To select a new i.LINK device and change the background video to that device, press .
- 4 To exit the i.LINK Control Panel and return to normal viewing, press the  button (or EXIT).



## Using the Timer

You can use the Timer to program the DTV to turn on and off and tune to a specific channel at two scheduled viewing times.

The first time you turned on the DTV, a setup screen prompted you to set the clock (see “Setting Up the DTV Automatically” on page 30). If you didn’t set the clock during this initial setup, you need to set it before you can use the Timer (see page 44).

### Setting the Timer

 You can also access the Timer through the Setup menu. For details, see page 58.

- 1 Press **TIMER**.

The Set Clock/Timers screen appears, with the current timer settings shown.

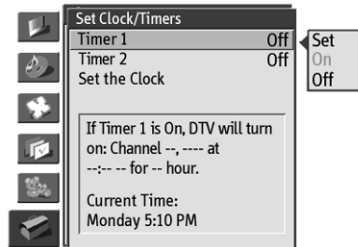

- 2 To set the Timer, move the joystick **▲** or **▼** to highlight Timer 1 or Timer 2, then press **⊕**.

 The clock must be set before you can set either of the Timers. If the clock is not set, Timer 1 and Timer 2 cannot be selected. To set the clock, see “Setting the Clock” on page 44.

- 3 Move the joystick **▲** or **▼** to highlight one of the following options, then press **⊕**.

Set	Select to set or change the timer settings for the selected Timer (Timer 1 or Timer 2).
On	Select to turn on the timer settings for the selected Timer (Timer 1 or Timer 2).
Off	Select to turn off the timer settings for the selected Timer (Timer 1 or Timer 2).

- 4 If you selected **Set** in step 3, the setup screen for the selected Timer (Timer 1 or Timer 2) appears.

- 5 Move the joystick **▲** and **▼** to set the day(s), time (hour, minute, AM/PM), duration, and channel number. Press **⊕** or **▶** to confirm each setting and move to the next setting. Press **◀** to go back to the previous setting.
- 6 After you've set the channel number, press **⊕** to save the Timer settings. The settings are displayed in the Timer screen and the Timer is set to On.

The DTV is now set to turn on, tune to the channel you've set, and then turn off at the times you set for that Timer. The Timer indicator on the front panel indicates the Timer is set.

**To turn a Timer setting on or off**

- ❑ Select On or Off in step 3 (page 43).

**To change a Timer setting**

- ❑ Set the timer (Timer 1 or Timer 2) again. The old timer setting is overwritten.

**To set a second Timer setting**

- ❑ Set the other unset timer (Timer 1 or Timer 2).

---

## Setting the Clock



You can also access the Timer through the Setup menu. For details, see page 58.





If you didn't set the clock during the DTV's initial setup (see page 30), you need to set it before you can set either of the Timers.

- 1 Press **TIMER**.  
The Timer Setup screen appears (as shown on page 43).
- 2 Move the joystick **▲** or **▼** to highlight **Set the Clock**, then press **⊕**.
- 3 Move the joystick **▲** and **▼** to set the current day and time (hour, minute, and AM/PM). Press **⊕** or move the joystick **▶** to confirm each setting and move to the next setting. Move the joystick **◀** to go back to the previous setting.
- 4 When you finish setting the day and time, press **⊕** to save the clock settings.







# Using the DTV Menus

## Overview

### To open and choose a menu

- 1 Press MENU to display the menu screen.
- 2 Move the joystick  or  to highlight the icon of the menu you want to select and press .
- 3 Move the joystick  or  to scroll through the options.
- 4 See the specific menu page for instructions on moving through the menu.





The Menu gives you access to the following features:

<i>Menu Icon</i>	<i>Description</i>	<i>Page</i>
	The Video menu allows you to make adjustments to your picture settings, lets you customize the Picture Mode based on the type of program you are viewing, and more.	46
	The Audio menu offers enhanced audio options such as listening to second audio programming (SAP), customizing the Effect of the sound on your DTV, and more.	48
	The Screen Mode menu allows you to make Wide Mode adjustments and make changes to the screen's vertical center and vertical size.	50
	The Channel Setup menu allows you to edit your Favorite Channels list, run the Auto Program function, and more.	52
	The Parental Control menu lets you control the viewing of programs based on their ratings.	54
	The Setup menu provides options for setting up your system, including selecting closed caption modes, setting the Timer, labeling Video inputs, changing the status of i.LINK devices, selecting the language of the on-screen menus, and more.	58

### To end a menu session

Press EXIT.

### To move from one menu to another

Move the joystick  to return to the menu icons. Move the joystick  or  to choose the next menu icon and press  to select it.

Using the DTV Menus



## Using the Video Menu

### To select the Video menu

- 1 Press MENU.
- 2 Move the joystick  $\uparrow$  or  $\downarrow$  to highlight the Video icon  and press  $\oplus$ .
- 3 Move the joystick  $\uparrow$  or  $\downarrow$  to scroll through the features.
- 4 Press  $\oplus$  to select a feature. That feature's adjustment appears.
- 5 Use the joystick to make the desired adjustments.
- 6 Press  $\oplus$  to select/set.
- 7 Press EXIT to exit the menu screen.

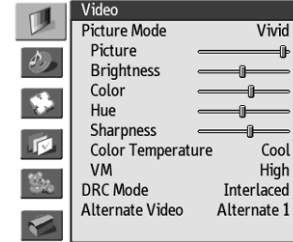



### To restore the factory default settings for Picture, Brightness, Color, Hue, and Sharpness, Color Temp and VM

- Press RESET on the remote control when in the Video menu.

The factory default settings are restored only for the Picture Mode that is currently selected.

## Selecting Video Options

 To change from one Video Mode to another, use the PIC MODE button on the remote control.

 You can customize each Picture Mode (Vivid, Standard, Movie, etc.) by changing the other video menu options (Picture, Brightness, Color, etc.).

The Video menu includes the following options.

Option	Description	
Picture Mode <i>Preset picture viewing modes</i>	Vivid	Select for enhanced picture contrast and sharpness.
	Standard	Recommended for Normal viewing conditions.
	Movie	Select to display a finely detailed picture for low-light environments.
	Game	Select to reduce the visibility of artifacts, which often appear in graphics and animation (such as in a video game). Game can also be used to improve the picture quality on channels with noisy or poor signal reception.
	Pro	Select to display a picture with minimum enhancements.
Picture	Adjust to increase picture contrast and deepen the color or decrease picture contrast and soften the color.	
Brightness	Adjust to brighten or darken the picture.	
Color	Adjust to increase or decrease color intensity.	



To change from one DRC Mode to another, use the DRC button on the remote control.

<b>Option</b>	<b>Description</b>						
Hue	Adjust to increase or decrease the green tones.						
Sharpness	Adjust to sharpen or soften the picture.						
Color Temperature	Choose from three color temperatures:						
White intensity adjustment	<table border="1"> <tr> <td>Cool</td> <td>Select to give the white colors a blue tint.</td> </tr> <tr> <td>Neutral</td> <td>Select to give the white colors a neutral tint.</td> </tr> <tr> <td>Warm</td> <td>Select to give the white colors a red tint (NTSC-Standard).</td> </tr> </table>	Cool	Select to give the white colors a blue tint.	Neutral	Select to give the white colors a neutral tint.	Warm	Select to give the white colors a red tint (NTSC-Standard).
Cool	Select to give the white colors a blue tint.						
Neutral	Select to give the white colors a neutral tint.						
Warm	Select to give the white colors a red tint (NTSC-Standard).						
VM Velocity Modulation	Sharpens picture definition to give every object a sharp, clean edge. Select from High, Low, Medium, Off.						
DRC Mode	Creates a high-resolution picture with 4x density, for high quality sources (i.e., DVD player, satellite receiver).						
Digital Reality Creation	<table border="1"> <tr> <td>Interlaced</td> <td>Recommended for moving pictures.</td> </tr> <tr> <td>Progressive</td> <td>Recommended for still images and text.</td> </tr> <tr> <td>CineMotion</td> <td>Provides an optimized display by automatically detecting film content and applying a reverse 3/2 pulldown process. Moving pictures will appear clearer and more natural-looking.</td> </tr> </table>	Interlaced	Recommended for moving pictures.	Progressive	Recommended for still images and text.	CineMotion	Provides an optimized display by automatically detecting film content and applying a reverse 3/2 pulldown process. Moving pictures will appear clearer and more natural-looking.
Interlaced	Recommended for moving pictures.						
Progressive	Recommended for still images and text.						
CineMotion	Provides an optimized display by automatically detecting film content and applying a reverse 3/2 pulldown process. Moving pictures will appear clearer and more natural-looking.						
Alternate Video	<p>Allows you to select from the available video streams for the current program. (For example, a sporting event that broadcasts multiple video streams.)</p> <p>To select an alternate video source, move the joystick <math>\blacktriangle</math> or <math>\blacktriangledown</math> to select an alternate video option and press <math>\oplus</math>. (Unavailable when alternate video streams are not broadcast.)</p>						

Using the DTV Menus



Using the Audio Menu

To select the Audio menu

- 1 Press MENU.
- 2 Move the joystick  $\uparrow$  or  $\downarrow$  to highlight the Audio icon  and press  $\oplus$ .
- 3 Move the joystick  $\uparrow$  or  $\downarrow$  to scroll through the options.
- 4 Press  $\oplus$  to select an option. That option's settings appear.
- 5 Use the joystick to scroll through the settings.
- 6 Press  $\oplus$  to select the desired setting.
- 7 Press EXIT to exit the menu screen.



To restore the factory default settings for Treble, Bass, and Balance

- Press RESET on the remote control when in the Audio menu.



Selecting Audio Options

 To change from one Effect to another, use the  $\text{\textcircled{D}}$  button on the inside panel of the remote control.

The Audio menu includes the following options:

Option	Description
Treble	Adjust to increase or decrease higher-pitched sounds.
Bass	Adjust to increase or decrease lower-pitched sounds.
Balance	Adjust to emphasize left or right speaker balance.
Steady Sound	On Select to stabilize the volume.
	Off Select to turn off Steady Sound.
Effect	TruSurround Select for surround sound (for stereo programs only).
	Simulated Adds a surround-like effect to mono programs.
	Off Normal stereo or mono reception.

 To change from one MTS Mode to another, use the MTS/SAP button on the remote control.

<b>Option</b>	<b>Description</b>	
<b>MTS</b> <i>Enjoy stereo, bilingual and mono programs</i>	<b>Stereo</b>	Select for stereo reception when viewing a program broadcast in stereo.
	<b>Auto SAP</b>	Select to automatically switch the DTV to second audio programs when a signal is received. (If no SAP signal is present, the DTV remains in Stereo mode.)
	<b>Mono</b>	Select for mono reception. (Use to reduce noise during weak stereo broadcasts.)
<b>Speaker On/Off</b>	<b>On</b>	Select to turn on the DTV speakers.
	<b>Off</b>	Select to turn off the DTV speakers and listen to the DTV's sound only through your external audio system speakers.
<b>Audio Output</b> <i>Easy control of volume adjustments</i>	<b>Variable</b>	The DTV's speakers are turned off, but the volume output from your audio system can still be controlled by the DTV's remote control.
	<b>Fixed</b>	The DTV's speakers are turned off and the volume output of the DTV is fixed. Use your audio receiver's remote control to adjust the volume through your audio system.
<b>Alternate Audio</b>	<p>Allows you to select from the available audio tracks for the current program. (For example, a sporting event that broadcasts multiple commentators.)</p> <p>To select an alternate audio track, move the joystick  or  to select an alternate audio option and press .</p> <p>(Unavailable when alternate audio tracks are not broadcast.)</p>	

Using the DTV Menus



## Using the Screen Mode Menu

### To select the Screen Mode menu

- 1 Press MENU.
- 2 Move the joystick **▲** or **▼** to highlight the Screen Mode icon  and press **⊕**.
- 3 Move the joystick **▲** or **▼** to scroll through the features.
- 4 Press **⊕** to select a feature. That feature's options appear.
- 5 Use the joystick to scroll through the options.
- 6 Press **⊕** to select the desired option.
- 7 Press EXIT to exit the menu screen.



### Selecting Screen Mode Options

 To change from one Wide Mode to another, use the WIDE MODE button on the remote control.

 If 4:3 Default is set to anything but Off, the Wide Mode setting changes only for the current channel. When you change channels (or inputs), Wide Mode is automatically replaced with the 4:3 Default setting. To retain the current Wide Mode setting as channels and inputs are changed, set 4:3 Default to Off.

The Screen Mode menu includes the following options:

Option	Description	
Wide Mode <i>Select a Wide Mode to use for 4:3 sources.</i>	Wide Zoom	Select to enlarge the 4:3 size picture, while the upper and lower parts of the picture are condensed to fit the wide screen.
	Normal	Select to return the 4:3 picture to normal mode.
	Full	Select to enlarge the 4:3 picture horizontally only, to fill the wide screen.
	Zoom	Select to enlarge the 4:3 picture horizontally and vertically to an equal aspect ratio that fills the wide screen.
(Wide Mode is unavailable while in Twin View.)		
4:3 Default <i>Select the default Screen Mode to use for 4:3 sources.</i>	Wide Zoom	Select to enlarge the 4:3 size picture, while the upper and lower parts of the picture are condensed to fit the wide screen.
	Normal	Select to return the 4:3 picture to normal mode.
	Full	Select to enlarge the 4:3 picture horizontally only, to fill the wide screen.
	Zoom	Select to enlarge the 4:3 picture horizontally and vertically to an equal aspect ratio that fills the wide screen.
	Off	Select to continue using the current Wide Mode setting when the channel or input is changed.



<b>Option</b>	<b>Description</b>
Vertical Center	Allows you to move the position of the picture up and down in the window. (Available only in Wide Zoom and Zoom modes.) Move the joystick <b>▲</b> or <b>▼</b> to choose a position and press <b>⊕</b> .
Vertical Size	Allows you to adjust the vertical size of the picture. (Available only in Wide Zoom and Zoom modes.) Move the joystick <b>▲</b> or <b>▼</b> to choose a correction and press <b>⊕</b> .

Using the DTV Menus



## Using the Channel Setup Menu

### To select the Channel Setup menu

- 1 Press MENU.
- 2 Move the joystick  $\uparrow$  or  $\downarrow$  to highlight the Channel Setup icon  and press  $\oplus$ .
- 3 Move the joystick  $\uparrow$  or  $\downarrow$  to scroll through the features.
- 4 Press  $\oplus$  to select a feature. That feature's options appear.
- 5 Use the joystick to scroll through the options.
- 6 Press  $\oplus$  to select the desired option.
- 7 Press EXIT to exit the menu screen.



### Selecting Channel Setup Options

The Channel Setup menu includes the following options:

Option	Description								
Favorite Channels	<table border="0"> <tr> <td>Edit</td> <td>Select to edit the Favorite Channels list. For details, see "Editing the Favorite Channels List" on page 36.</td> </tr> </table>	Edit	Select to edit the Favorite Channels list. For details, see "Editing the Favorite Channels List" on page 36.						
Edit	Select to edit the Favorite Channels list. For details, see "Editing the Favorite Channels List" on page 36.								
Channel Fix	<table border="0"> <tr> <td>Off</td> <td>Turns off Channel Fix.</td> </tr> <tr> <td>VIDEO 1</td> <td>Use this setting if you have connected the device to the Audio and Video IN jacks.</td> </tr> <tr> <td>2-6</td> <td>"Fix" your DTV's channel setting to channels 2-6 and use the cable box, VCR or satellite receiver to change channels. Select one of these settings if you connected the device to the VHF/UHF jack.</td> </tr> <tr> <td>Cable 2-6</td> <td>Same as 2-6, except you select one of these settings if you connected the device to the CABLE jack.</td> </tr> </table>	Off	Turns off Channel Fix.	VIDEO 1	Use this setting if you have connected the device to the Audio and Video IN jacks.	2-6	"Fix" your DTV's channel setting to channels 2-6 and use the cable box, VCR or satellite receiver to change channels. Select one of these settings if you connected the device to the VHF/UHF jack.	Cable 2-6	Same as 2-6, except you select one of these settings if you connected the device to the CABLE jack.
Off	Turns off Channel Fix.								
VIDEO 1	Use this setting if you have connected the device to the Audio and Video IN jacks.								
2-6	"Fix" your DTV's channel setting to channels 2-6 and use the cable box, VCR or satellite receiver to change channels. Select one of these settings if you connected the device to the VHF/UHF jack.								
Cable 2-6	Same as 2-6, except you select one of these settings if you connected the device to the CABLE jack.								
Auto Program	<table border="0"> <tr> <td>Automatically programs the DTV for all receivable channels.</td> <td></td> </tr> <tr> <td>Find and Overwrite</td> <td>Select to automatically program the DTV for all receivable channels for the selected input (Cable or VHF/UHF).</td> </tr> <tr> <td>DTV Auto Add</td> <td>Select to automatically add new digital channels to the digital channel list. (Available only for VHF/UHF input.)</td> </tr> </table>	Automatically programs the DTV for all receivable channels.		Find and Overwrite	Select to automatically program the DTV for all receivable channels for the selected input (Cable or VHF/UHF).	DTV Auto Add	Select to automatically add new digital channels to the digital channel list. (Available only for VHF/UHF input.)		
Automatically programs the DTV for all receivable channels.									
Find and Overwrite	Select to automatically program the DTV for all receivable channels for the selected input (Cable or VHF/UHF).								
DTV Auto Add	Select to automatically add new digital channels to the digital channel list. (Available only for VHF/UHF input.)								

<b>Option</b>	<b>Description</b>
Channel Skip/Add	<p>Allows you to customize the channel list that appears when using the CH+/- buttons on the remote control. The DTV maintains separate channel lists for digital and analog channels.</p> <p>Digital      Select to add or skip digital channels.</p> <p>Analog      Select to add or skip analog channels.</p> <ol style="list-style-type: none"> <li>1 Move the joystick <b>▲</b> or <b>▼</b> to scroll through the channels until you find the channel you want to skip/add.</li> <li>2 Press <b>⊕</b> to select it.</li> <li>3 Move the joystick <b>▲</b> or <b>▼</b> to toggle between Add and Skip. Then press <b>⊕</b> to select.</li> <li>4 Move the joystick <b>◀</b> to return to the Channel Setup menu, or press EXIT to exit the menus.</li> </ol>
Channel Logo	<p>Allows you to assign logos to channel numbers.</p> <p>Channel List      Select to display the channel list.</p> <p>To assign a logo for a channel number:</p> <ol style="list-style-type: none"> <li>1 Move the joystick <b>▲</b> or <b>▼</b> to highlight the channel number to which you want to assign a logo. Then press <b>⊕</b> to select that channel number.</li> <li>2 Move the joystick <b>◀▶▲▼</b> to highlight one of the logos. Then press <b>⊕</b> to assign that logo to the selected channel number.</li> <li>3 Move the joystick <b>◀</b> to return to the Channel Setup menu, or press EXIT to exit the menus.</li> </ol>
Digital Signal Strength	<p>Displays the strength of the terrestrial digital broadcast signal, to help you adjust your antenna to optimize signal reception. When the DTV is receiving a good signal (the signal is locked and there are no errors in the signal), the green light appears. Adjust the antenna until the green light appears.</p>

## Using the DTV Menus



### Using the Parental Control Menu

The Parental Control menu allows you to set up the DTV to block programs according to their content and rating levels. These ratings are assigned by a federal rating board. Not all programs are rated. Using the Parental Lock blocks programs with a specific rating, but it does not block an entire channel.

#### To select the Parental Control menu

- 1 Press MENU.
- 2 Move the joystick or to highlight the Parental Control icon and press .
- 3 Use the 0-9 buttons on the remote control to enter your four-digit password.
- 4 If this is your first time setting a password, confirm your password by entering it again. (The Parental Control menu options appear.)
- 5 Move the joystick or to scroll through the settings.
- 6 Press to select the desired option.
- 7 Press EXIT to exit the menu screen.



You need your password for any future access into the Parental Control menu. If you lose your password, see "Lost password" on page 69.

## Using the Parent Menu

 If you are not familiar with the Parental Guideline rating system, you should select Child, Youth, or Young Adult to help simplify the rating selection. To set more restrictive ratings, select Custom.

The Parent menu includes the following options.

<b>Option</b>	<b>Description</b>	
Parental Lock	Off	Parental lock is off. No programs are blocked from viewing.
<i>Turn ratings on/off and select a rating system</i>	Child	Maximum ratings permitted are: <input type="checkbox"/> US: TV-Y, TV-G, G <input type="checkbox"/> Canada: TV-Y, C, G
	Youth	Maximum ratings permitted are: <input type="checkbox"/> US: TV-PG, PG <input type="checkbox"/> Canada: TV-PG, PG, 8 ans+
	Young Adult	Maximum ratings permitted are: <input type="checkbox"/> US: TV-14, PG-13 <input type="checkbox"/> Canada: TV-14, 14+, 13 ans+
	Custom	Select to set ratings manually. <input type="checkbox"/> US: See page 56 for details. <input type="checkbox"/> Canada: See page 57 for details.
Change Password	For changing your password.	
Select Country	USA	Select to use USA ratings (see pag e56).
	Canada	Select to use Canadian ratings (see page 57).

**United States:  
Selecting Custom  
Rating Options**

For the United States, the Custom Rating Menu includes the following options. (For Canada, see page 57.)

 To ensure maximum blocking capability, the age-based ratings should be blocked.

 The content ratings will increase depending on the level of the age-based rating. For example, a program with a TV-PG V (Violence) rating may contain moderate violence, while a TV-14 V (Violence) rating may contain more intense violence.

 If you block unrated TV programs, be aware that the following types of programs may be blocked: emergency broadcasts, political programs, sports, news, public service announcements, religious programs and weather.

<b>Option</b>	<b>Description</b>
Movie Rating	G All children and General Audience.
	PG Parental Guidance suggested.
	PG-13 Parental Guidance for children under 13.
	R Restricted viewing, parental guidance is suggested for children under 17.
	NC-17 and X No one 17 and under allowed.
TV Rating	Age-Based Options
<i>Block programs by their rating, content or both</i>	TV-Y All children.
	TV-Y7 Directed to older children.
	TV-G General Audience.
	TV-PG Parental Guidance suggested.
	TV-14 Parents Strongly cautioned.
	TV-MA Mature Audience only.
	Content-Based Options
	FV Fantasy Violence.
	D Suggestive Dialogue.
	L Strong Language.
	S Sexual situations.
	V Violence.
Unrated <i>Block programs or movies that are broadcast without a rating</i>	Block Blocks all programs and movies that are broadcast without a rating.
	Allow Allows programs and movies that are broadcast without a rating.

---

**Canada:  
Selecting Custom  
Rating Options**

For Canada, the Custom Rating Menu includes the following options. (For the US, see page 56.)

<b>Option</b>	<b>Description</b>	
English Rating	C	All children.
	C8+	Children 8 years and older.
	G	General programming.
	PG	Parental Guidance.
	14+	Viewers 14 and older.
	18+	Adult programming.
French Rating	G	General programming.
	8 ans+	Not recommended for young children.
	13 ans+	Not recommended for ages under 13.
	16 ans+	Not recommended for ages under 16.
	18 ans+	Programming restricted to adults.
USA TV Rating	See page 56 for details.	

---

**Viewing Blocked  
Programs**

You can view a blocked program by pressing the ENTER button when tuned to a blocked program. Entering the correct password temporarily switches off the Parental Lock. To reactivate the Parental Lock settings, turn off the DTV. When the DTV is turned on again, your Parental Controls settings are reactivated.

Using the DTV Menus



Using the Setup Menu

To select the Setup menu

- 1 Press MENU.
- 2 Move the joystick  $\uparrow$  or  $\downarrow$  to highlight the Setup icon  and press  $\oplus$ .
- 3 Move the joystick  $\uparrow$  or  $\downarrow$  to scroll through the features.
- 4 Press  $\oplus$  to select a feature. (That feature's options appear.)
- 5 Move the joystick  $\uparrow$  or  $\downarrow$  to scroll through the options.
- 6 Press  $\oplus$  to select the desired option.
- 7 Press EXIT to exit the menu screen.

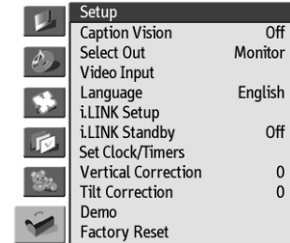



Selecting Setup Options

The Setup Menu includes the following options:

Option	Description
Caption Vision	Allows you to select from three closed caption modes (for programs that are broadcast with closed caption).
CC1, CC2, CC3, CC4	Displays a printed version of the dialog or sound effects of a program. (Should be set to CC1 for most programs.)
TEXT1, TEXT2, TEXT3, TEXT4	Displays network/station information presented using either half or the whole screen (if available). For closed captioning, set to CC1.
Info Banner	Displays the program name and the time remaining in the program (if the broadcaster offers this service). Displays when the channel is changed or the DISPLAY button is pressed.
Off	Turns off Caption Vision.
Select Out	Allows you to select which input to pass through to the equipment connected to the SELECT OUT jacks on the DTV.
Monitor	Outputs the picture displayed on the screen.
TV	Outputs the signal that the TV is tuned to (regardless of the picture displayed on the screen).
VIDEO 1-4	Outputs the signal input to the TV (regardless of the picture displayed on the screen).



 You can also use the Video Input option to assign video inputs to i.LINK devices. When you select that video input, an i.LINK connection is established. Only i.LINK devices that are set to Show (see "i.LINK Setup") and which support video input connection are listed.

 For details about using the i.LINK Control Panel, see page 42.

 For details about power consumption in standby modes, see "Specifications" on page 70.







Option	Description						
Video Input	<p>Allows you to select labels to help you recognize devices connected to the audio/video jacks on the DTV. For example, if you have a DVD player connected to the VIDEO 2 jack, you can select the label DVD for the VIDEO 2 input.</p> <p>To select a label for a video input:</p> <ol style="list-style-type: none"> <li>1 Move the joystick <math>\uparrow</math> or <math>\downarrow</math> to highlight the video input (VIDEO 1-6) that you want to assign a label. Then press <math>\oplus</math> to select the input.</li> <li>2 Move the joystick <math>\uparrow</math> or <math>\downarrow</math> to highlight one of the displayed labels. Then press <math>\oplus</math> to select it.</li> </ol> <p>If you select the label Skip, your DTV skips this connection when you press the TV/VIDEO button. i.LINK devices cannot be assigned to VIDEO 5 or 6.</p>						
Language	Select to display all on-screen menus in your language of choice (English, Espanol, Francais).						
i.LINK Setup	<p>Select to display a list of i.LINK devices that are connected to the DTV. To change the status of an i.LINK device:</p> <ol style="list-style-type: none"> <li>1 Move the joystick <math>\uparrow</math> or <math>\downarrow</math> to highlight an i.LINK device. Then press <math>\oplus</math> to select the device.</li> <li>2 Move the joystick <math>\uparrow</math> or <math>\downarrow</math> to highlight one of the following options. Then press <math>\oplus</math> to select it.</li> </ol> <table border="1"> <tbody> <tr> <td>Show</td> <td>Select to display this device in the i.LINK Control Panel.</td> </tr> <tr> <td>Hide</td> <td>Select to not display this device in the i.LINK Control Panel. This is for devices that are connected to, but not communicating with, the DTV (or for devices that you don't want to appear in the i.LINK Control Panel).</td> </tr> <tr> <td>Delete</td> <td>Select for i.LINK devices that you have disconnected from the DTV. To reconnect the device, see page 28.</td> </tr> </tbody> </table>	Show	Select to display this device in the i.LINK Control Panel.	Hide	Select to not display this device in the i.LINK Control Panel. This is for devices that are connected to, but not communicating with, the DTV (or for devices that you don't want to appear in the i.LINK Control Panel).	Delete	Select for i.LINK devices that you have disconnected from the DTV. To reconnect the device, see page 28.
Show	Select to display this device in the i.LINK Control Panel.						
Hide	Select to not display this device in the i.LINK Control Panel. This is for devices that are connected to, but not communicating with, the DTV (or for devices that you don't want to appear in the i.LINK Control Panel).						
Delete	Select for i.LINK devices that you have disconnected from the DTV. To reconnect the device, see page 28.						
i.LINK Standby	<table border="1"> <tbody> <tr> <td>On</td> <td>Allows the i.LINK signal to pass through to connected i.LINK devices even when the DTV is turned off. Front panel LED is orange. The DTV uses more standby power than when this option set to Off.</td> </tr> <tr> <td>Off</td> <td>Does not allow the i.LINK signal to pass through to connected i.LINK devices when the DTV is turned off. Front panel LED is red. The DTV uses less standby power than when this option is set to On.</td> </tr> </tbody> </table>	On	Allows the i.LINK signal to pass through to connected i.LINK devices even when the DTV is turned off. Front panel LED is orange. The DTV uses more standby power than when this option set to Off.	Off	Does not allow the i.LINK signal to pass through to connected i.LINK devices when the DTV is turned off. Front panel LED is red. The DTV uses less standby power than when this option is set to On.		
On	Allows the i.LINK signal to pass through to connected i.LINK devices even when the DTV is turned off. Front panel LED is orange. The DTV uses more standby power than when this option set to Off.						
Off	Does not allow the i.LINK signal to pass through to connected i.LINK devices when the DTV is turned off. Front panel LED is red. The DTV uses less standby power than when this option is set to On.						

---

## Using the DTV Menus

 You can also access the Timer using the TIMER button on the remote control.

 Both Vertical Correction and Tilt Correction are done while the picture is in Full Mode. However, the adjustments are also reflected in other viewing modes: Wide Zoom, Zoom, Normal, Twin View, etc.

<b>Option</b>	<b>Description</b>
Set Clock/Timers	Select to set the clock and to program your DTV to turn on and off at two scheduled viewing times. For details, see page 43.
Vertical Correction	Allows you to make a vertical correction to the picture within the DTV screen. Move the joystick  or  to choose a correction between +5 and -5 and press  . You can use the horizontal bars at the top and bottom of the screen for reference as you make the adjustment. Normally, vertical correction only needs to be adjusted the first time you turn on the unit and after the unit is moved to a new location.
Tilt Correction	Allows you to correct any tilt of the picture. Move the joystick  or  to choose a correction between +7 and -7 and press  . You can use the horizontal bars at the top and bottom of the screen for reference as you make the adjustment. Normally, tilt correction only needs to be adjusted the first time you turn on the unit and after the unit is moved to a new location.
Demo	Runs a demonstration of the features of the DTV.
Factory Reset	Restores all menu options to their original factory settings. <b>WARNING:</b> Factory Reset clears all settings from memory, including channel lists, favorite channels, menu settings, timers, clock, etc.

# Other Information

## Overview

This chapter includes the following topics:

<i>Topic</i>	<i>Page</i>
Programming the Remote Control	62
Operating Other Components with Your DTV Remote Control	65
About i.LINK	67
Troubleshooting	68
Specifications	70
Index	71

## Programming the Remote Control

The remote control is preset to operate Sony brand video equipment.

<b>Sony Equipment</b>	<b>Switch Position on Remote Control</b>	<b>Programmable Code Number</b>
Beta, ED Beta VCRs	AV1	303
8 mm VCR	AV2	302
VHS VCR	AV3	301
DVD Player	DVD	751

If you have video equipment other than Sony brand that you want to control with the DTV's remote control, use the following procedures to program the remote control.

 The equipment must have infrared (IR) remote capability in order to be used with the remote control.

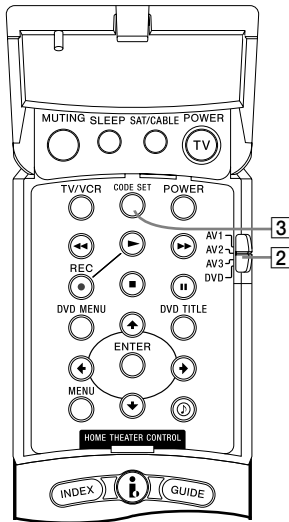

- 1 Check the list of the "Manufacturer's Codes" listed on page 64, and find the three-digit code number for the manufacturer for your equipment. (If more than one code number is listed, start with the number listed first.)
- 2 Open the lid on the remote control. Then move the slide switch to one of the four positions (AV1, AV2, AV3, DVD).

- 3 Press CODE SET.

 You must perform step 4 within 10 seconds of step 3.

- 4 Close the lid on the remote control and enter the three-digit manufacturer's code number.
- 5 Press ENTER.
- 6 To check if the code number works, aim the DTV's remote control at the equipment and press the green POWER button that corresponds with that equipment. If it responds, you are done. If not, try using another code listed for that manufacturer.

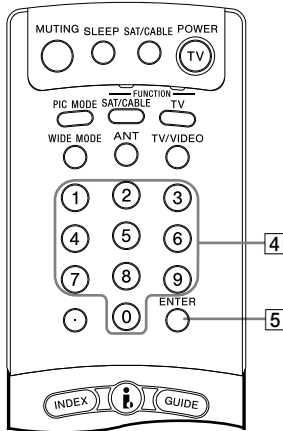

**Tips**

- ❑ If more than one code number is listed, try entering them one by one until you come to the correct code for your component.
- ❑ If you enter a new code number, the code number you previously entered at that setting is erased.
- ❑ In some cases, you may not be able to operate your component with the Sony remote control. In such cases, use the component's own remote control unit.

## Other Information

### Manufacturer's Codes

#### VCRs

<b>Manufacturer</b>	<b>Code</b>
Sony	301, 302, 303
Admiral (M. Ward)	327
Aiwa	338, 344
Audio	314, 337
Dynamic	
Broksonic	319, 317
Canon	309, 308
Citizen	332
Craig	302, 332
Criterion	315
Curtis Mathes	304, 338, 309
Daewoo	341, 312, 309
DBX	314, 336, 337
Dimensia	304
Emerson	319, 320, 316, 317, 318, 341
Fisher	330, 335
Funai	338
General	329, 304, 309
Electric	
Go Video	322, 339, 340
Goldstar	332
Hitachi	306, 304, 305, 338
Instant Replay	309, 308
JC Penney	309, 305, 304, 330, 314, 336, 337
JVC	314, 336, 337, 345, 346, 347
Kenwood	314, 336, 332, 337
LXI (Sears)	332, 305, 330, 335, 338
Magnavox	308, 309, 310
Marantz	314, 336, 337
Marta	332
Memorex	309, 335
Minolta	305, 304
Mitsubishi/ MGA	323, 324, 325, 326
Multitech	325, 338, 321
NEC	314, 336, 337
Olympic	309, 308
Optimus	327

<b>Manufacturer</b>	<b>Code</b>
Orion	317
Panasonic	308, 309, 306, 307
Pentax	305, 304
Philco	308, 309
Philips	308, 309, 310
Pioneer	308
Quasar	308, 309, 306
RCA/ PROSCAN	304, 305, 308, 309, 311, 312, 313, 310, 329
Realistic	309, 330, 328, 335, 324, 338
Sansui	314
Samsung	322, 313, 321
Sanyo	330, 335
Scott	312, 313, 321, 335, 323, 324, 325, 326
Sharp	327, 328
Shintom	315
Signature 2000 (M. Ward)	338, 327
SV2000	338
Sylvania	308, 309, 338, 310
Symphonic	338
Tashiro	332
Tatung	314, 336, 337
Teac	314, 336, 338, 337
Technics	309, 308
Toshiba	312, 311
Wards	327, 328, 335, 331, 332
Yamaha	314, 330, 336, 337
Zenith	331

#### Laserdisc Players

<b>Manufacturer</b>	<b>Code</b>
Sony	701
Panasonic	704, 710
Pioneer	702

#### DVD Players

<b>Manufacturer</b>	<b>Code</b>
Sony	751
GE	755
Hitachi	758
JVC	756
Magnavox	757
Mitsubishi	761
Oritron	759
Panasonic	753
Philips	757
Pioneer	752
RCA/ PROSCAN	755
Samsung	758
Toshiba	754
Zenith	760

#### Cable Boxes

<b>Manufacturer</b>	<b>Code</b>
Sony	230
Hamlin/Regal	222, 223, 224, 225, 226
Jerrold/G. I.	201, 202, 203, 204, 205, 206, 207, 208, 218
Oak	227, 228, 229
Panasonic	219, 220, 221
Pioneer	214, 215
Scientific	209, 210, 211
Atlanta	
Tocom	216, 217
Zenith	212, 213

#### Satellite Receivers

<b>Manufacturer</b>	<b>Code</b>
Sony	801
Dish Network	810
Echostar	810
General	802
Electric	
Hitachi	805
Hughes	804
Mitsubishi	809
Panasonic	803
RCA/ PROSCAN	802, 808
Toshiba	806, 807

## Operating Other Components with Your DTV Remote Control

### Operating a VCR

Move the slide switch to the position you programmed for the VCR.

<i>To Do This ...</i>	<i>Press</i>
Turn on/off	POWER
Select VCR	TV/VIDEO
Change channels	CH +/-
Record	▶ and REC simultaneously.
Play	▶
Stop	■
Fast forward	▶▶
Rewind the tape	◀◀
Pause	(press again to resume normal playback)
Search the picture forward or backward	▶▶ or ◀◀ during playback (release to resume normal playback)
Change input mode	TV/VCR

### Operating a DVD Player

Move the slide switch to the position you programmed for the DVD player.

<i>To Do This ...</i>	<i>Press</i>
Turn on/off	POWER
Select DVD	TV/VIDEO
Play	▶
Stop	■
Pause	
Step through different tracks of an audio disc	▶▶ to step forward or ◀◀ to step backward
Step through different chapters of a video disc	CH+ to step forward or CH- to step backward
Display the DVD menu	DVD MENU
Display the menu (Setup)	MENU

*Other Information*

**Operating a Cable Box**

<i>To Do This ...</i>	<i>Press</i>
Turn on/off	SAT/CABLE (green POWER button)
Select Cable Box	SAT/CABLE (FUNCTION button)
Select a channel	0-9 buttons, ENTER
Change channels	CH +/-
Back to previous channel	JUMP

**Operating a Satellite Receiver**

<i>To Do This ...</i>	<i>Press</i>
Turn on/off	SAT/CABLE (green POWER button)
Select Satellite Receiver	SAT/CABLE (FUNCTION button)
Select a channel	0-9 buttons, ENTER
Change channels	CH +/-
Back to previous channel	JUMP
Display channel number	DISPLAY
Display satellite guide	GUIDE
Display satellite menu	MENU
Move highlight (cursor)	Move joystick ◀ ▶ ▶▶ ▶▶
Select item	⊕ button

**Operating an MDP (Laserdisc Player)**

Move the slide switch to the position you programmed for the MDP.

<i>To Do This ...</i>	<i>Press</i>
Turn on/off	POWER
Play	▶
Stop	■
Pause	(press again to resume normal playback)
Search the picture forward or backward	▶▶ or ◀◀ during playback (release to resume normal playback)
Search a chapter forward or backward	CH +/-



## About i.LINK

i.LINK is a digital serial interface for handling digital video, digital audio, and other data in two directions between equipment having an i.LINK jack, and for controlling other equipment.

i.LINK compatible equipment can be connected using a single i.LINK cable. Possible applications are operations and data transactions with various digital AV equipment. When two or more i.LINK compatible devices are connected to the DTV, operations and data transactions are possible not only with the equipment that this unit is connected to, but also with the other devices via the directly connected equipment.

Note, however, that the method of operation sometimes varies according to the characteristics and specifications of the equipment to be connected, and that operations and data transactions are sometimes not possible on some connected equipment.

 Before connecting this unit to i.LINK compatible equipment, refer to the instruction manual of the equipment to be connected.

---

### About the Name i.LINK

i.LINK is Sony's term for the IEEE 1394 data transport bus, and is a trademark approved by many corporations. IEEE 1394 is an international standard standardized by the Institute of Electrical Electronic Engineers.

---

### i.LINK as a Repeater

This device functions as a repeater or node, so that the i.LINK specific digital signals provided by one device will be relayed to another device that is connected to the first device. This will occur even when the second device does not have the means to use the repeater digital signals.

When i.LINK devices are connected to this DTV, the maximum bit rate (the speed at which data can be sent or received) is 200 Mbps (megabits per second).

To use this DTV as an i.LINK repeater when the unit is powered off, be sure that the i.LINK Standby option is set to 0n, as described on page 59.

## Troubleshooting

<b>Problem</b>	<b>Possible Remedies</b>
No picture (screen not lit), no sound	<ul style="list-style-type: none"><li><input type="checkbox"/> If your DTV does not turn on, and a red light keeps flashing, your DTV may need service. Call your local Sony Service Center.</li><li><input type="checkbox"/> Make sure the power cord is plugged in.</li><li><input type="checkbox"/> Push the power button on the front of the DTV.</li><li><input type="checkbox"/> Check to see if the TV/VIDEO setting is correct: when watching TV, set to TV. When watching connected equipment, set to VIDEO 1, 2, 3, 4, 5 or 6, as appropriate.</li><li><input type="checkbox"/> Try another channel (it could be station trouble).</li></ul>
Remote control does not operate	<ul style="list-style-type: none"><li><input type="checkbox"/> Batteries could be weak. Replace the batteries.</li><li><input type="checkbox"/> Press TV (FUNCTION) when operating the DTV.</li><li><input type="checkbox"/> Make sure the DTV's power cord is connected securely to the wall outlet.</li><li><input type="checkbox"/> Locate the DTV at least 3-4 feet away from fluorescent lights.</li><li><input type="checkbox"/> Check the orientation of the batteries.</li></ul>
Dark, poor or no picture (screen lit), good sound	<ul style="list-style-type: none"><li><input type="checkbox"/> Adjust the Picture setting in the Video menu (see page 46).</li><li><input type="checkbox"/> Adjust the Brightness setting in the Video menu (see page 46).</li><li><input type="checkbox"/> Check antenna/cable connections.</li></ul>
Good picture, no sound	<ul style="list-style-type: none"><li><input type="checkbox"/> Press MUTING so that Muting disappears from the screen (see page 4).</li></ul>
Cannot receive upper channels (UHF) when using an antenna	<ul style="list-style-type: none"><li><input type="checkbox"/> Use Auto Program in the Channel Setup menu to add receivable channels that are not presently in memory (see page 52).</li></ul>
No color	<ul style="list-style-type: none"><li><input type="checkbox"/> Adjust the Color settings in the Video menu (see page 46).</li></ul>
Only snow and noise appear on the screen	<ul style="list-style-type: none"><li><input type="checkbox"/> Check the antenna/cable connections.</li><li><input type="checkbox"/> Try another channel (it could be station trouble).</li><li><input type="checkbox"/> Press ANT to change the input mode (see page 4).</li></ul>
Picture is displayed, but snow or noise is obvious	<ul style="list-style-type: none"><li><input type="checkbox"/> Try setting the Picture Mode to Game (see page 46).</li></ul>
Only a black screen appears	<ul style="list-style-type: none"><li><input type="checkbox"/> Indicates there is no signal for the digital channel you are tuned to.</li></ul>
Dotted lines or stripes	<ul style="list-style-type: none"><li><input type="checkbox"/> Adjust the antenna.</li><li><input type="checkbox"/> Move the DTV away from noise sources such as cars, neon signs, or hair-dryers.</li></ul>
DTV is fixed to one channel	<ul style="list-style-type: none"><li><input type="checkbox"/> Use Auto Program in the Channel Setup menu to add receivable channels that are not presently in memory (see page 52).</li><li><input type="checkbox"/> Check your Channel Fix settings (see page e52).</li></ul>
Double images or ghosts	<ul style="list-style-type: none"><li><input type="checkbox"/> Use a highly directional outdoor antenna or a cable (if the problem is caused by reflections from nearby mountains or tall buildings).</li></ul>
Cannot select menu item	<ul style="list-style-type: none"><li><input type="checkbox"/> If the item you want to choose appears in gray, it is not available to be selected.</li></ul>
Cannot receive any channels when using cable TV	<ul style="list-style-type: none"><li><input type="checkbox"/> Use Auto Program in the Channel Setup menu to add receivable channels that are not presently in memory (see page 52).</li><li><input type="checkbox"/> Check your cable settings.</li></ul>

<b>Problem</b>	<b>Possible Remedies</b>
Cannot gain enough volume when using a cable box	<ul style="list-style-type: none"> <li>❑ Increase the volume of the cable box using the cable box's remote control. Then press TV (FUNCTION) and adjust the DTV's volume.</li> </ul>
Cannot receive channels	<ul style="list-style-type: none"> <li>❑ Use Auto Program in the Channel Setup menu to add receivable TV channels that are not presently in memory (see page 52).</li> </ul>
Unable to select a channel	<ul style="list-style-type: none"> <li>❑ Use Auto Program in the Channel Setup menu to add receivable TV channels that are not presently in memory (see page 52).</li> </ul>
Lost password	<ul style="list-style-type: none"> <li>❑ In the password screen (see page 54), enter the following master password: 4357. The master password clears your previous password; it cannot be used to temporarily unblock channels.</li> </ul>
Cannot change channels with the remote control	<ul style="list-style-type: none"> <li>❑ Be sure you have not inadvertently switched your DTV from channel 3 or 4 setting if you are using another device to change channels.</li> <li>❑ If you are using another device to control channels, be sure the "function" button for that device has been pressed. For example, if you are using your satellite receiver to control channels, be sure to press the SAT/CABLE button.</li> </ul>
Cannot cycle through the other video equipment connected to the DTV	<ul style="list-style-type: none"> <li>❑ Be sure the Video Input feature has not been set to Skip (see page 59).</li> </ul>
There is a black box on the screen	<ul style="list-style-type: none"> <li>❑ You have selected a text option in the Setup menu and no text is available. (See page 58 to reset Setup selections.) To turn this feature off, select Off in the Caption Vision option. If you were trying to get closed captioning, select CC1 instead of Text 1-4.</li> </ul>
There is no Twin Picture or it is just static	<ul style="list-style-type: none"> <li>❑ Be sure your twin picture is set to a video source/channel that has a program airing.</li> <li>❑ You may be tuned to a video input with nothing connected to it. Try cycling through your video inputs using the TV/VIDEO button.</li> </ul>
The right Twin Picture window is just a black box	<ul style="list-style-type: none"> <li>❑ You can display digital channels in the left Twin View window, but not the right. Pressing ⊕ while the black box is active will exit Twin View and tune to that digital channel.</li> </ul>
I get the same program in the window picture as in the main picture	<ul style="list-style-type: none"> <li>❑ Both may be set to the same channel. Try changing channels in either the main picture or the window picture.</li> <li>❑ You may be running all your channels through a cable box. The cable box will only unscramble one signal at a time, so you cannot use the Twin View feature. If possible, run a direct cable to your DTV's CABLE input. (This will only work if your cable system provides an unscrambled signal.)</li> </ul>
I cannot get anything but TV channels in my second picture	<ul style="list-style-type: none"> <li>❑ Be sure the Video Input feature has not been set to Skip (see page 59).</li> </ul>

If, after reading these operating instructions, you have additional questions related to the use of your Sony television, please call our Customer Information Services Center at 1-800-222-SONY (7669) (U.S. residents only) or (416) 499-SONY (7669) (Canadian residents only).

## Other Information

## Specifications

Picture Tube	FD Trinitron® tube	
Antenna	75 ohm external terminal for VHF/UHF	
Television System	NTSC, American TV Standard, ATSC	
Channel Coverage		
DTV	1-99	
VHF	2-13	
UHF	14-69	
CATV	1-125	
Power Requirements	120V, 60 Hz	
Inputs/Outputs		
Video (IN)	4 total (1 on front panel)	1 V <sub>p-p</sub> , 75 ohms unbalanced, sync negative
S Video (IN)	4	Y: 1 V <sub>p-p</sub> , 75 ohms unbalanced, sync negative C: 0.286 V <sub>p-p</sub> (Burst signal), 75 ohms
Component Video Input	2 (Y, P <sub>B</sub> , P <sub>R</sub> )	Y: 1.0 V <sub>p-p</sub> , 75 ohms unbalanced, sync negative P <sub>B</sub> : 0.7 V <sub>p-p</sub> , 75 ohms P <sub>R</sub> : 0.7 V <sub>p-p</sub> , 75 ohms
Audio (IN)	6 total (1 on front panel)	500 mVrms (100% modulation) Impedance: 47 kilohm
Audio (OUT)	1	More than 408 mVrms at the maximum volume setting (Variable) More than 408 mVrms (Fixed) Impedance (output): 2 kilohms
SELECT OUT	1 Video 1 Audio	1 V <sub>p-p</sub> , 75 ohms unbalanced, sync negative More than 408 mVrms (100% modulation) Impedance (output): 2 kilohms
Digital Audio Optical Output Dolby Digital/PCM	1	Optical Rectangular (1)
CONTROL S (IN/OUT)	1	
i.LINK S200	2	4-pin S200 i.LINK terminal (2)
Supplied Accessories		
Remote Control	RM-Y185	
AA (R6) Batteries	2 supplied for remote control	
Optional Accessories		
AV Cable	VMC-810/820/830 HG	
Audio Cable	RKC-515HG	
i.LINK Cable	VMC-IL4415 (4-pin to 4-pin, 1.5 meters), VMC-IL4435 (4-pin to 4-pin, 3.5 meters)	
Component Video Cable	VMC-10/30 HG	
TV Stand	SU-34XBR2	
Visible Screen Size	34 in (855.7 mm) picture measured diagonally	
Actual CRT Size	36 in (926.4 mm) picture measured diagonally	
Speaker Output	15 x 2	
Dimensions (W x H x D)	994 x 622 x 591.3 mm (39 3/16 x 24 1/2 x 23 5/16 in)	
Mass	93 kg (206 lbs)	
Power Consumption		
In Use	330 W	
In Standby	2.5 W	
In i.LINK Standby	34 W	

Design and specifications are subject to change without notice.

---

# Index

0 – 9 buttons 5

4:3 aspect ratio 37

4:3 Default settings 50

## A

ADD FAVORITE button 4, 34

Alternate Audio, setting 49

Alternate Video, setting 47

ANT button 4

antenna, connecting 12

Audio menu 45, 48

AUDIO OUT (VAR/FIX) L (MONO)/R jacks,  
described 11

Audio Output, setting 49

audio receiver, connecting 20

Auto Program (channel setup) 30, 52

Auto SAP setting 49

AV1-3/DVD slide switch 6

## B

balance, adjusting 48

bass, adjusting 48

batteries, inserting in remote 3

bilingual audio, setting 49

blocking programs. See ratings.

brightness, adjusting 46

## C

cable

box, connecting with VCR 15  
connecting 12

with VCR, connecting 14

cable box, using with TV remote control 66

CABLE jack, described 11

camcorder, connecting 23

Caption Vision, setting 58

CATV. see cable

CH buttons 5

Change Password 55

Channel Fix, setting 52

Channel Logo, setting 53

Channel Setup menu 45, 52

Channel Skip/Add, setting 53

channels, changing 5

clock, setting 30

closed caption modes 45, 58

CODE SET button 6

color temperature, adjusting 47

color, adjusting 46

CONTROL S 29

CONTROL S IN/OUT jacks, described 11

Country, setting 55

cursor movement buttons 6, 10

## D

Delete setting, in i.LINK Setup 59

Demo, running 30, 60

digital channels

using the Guide 32

Digital Reality Creation

described 2

setting 47

Digital Signal Strength 53

digital TV FAQs 7

DISPLAY button 4

DRC CINEMOTION button 5

DVD MENU button 6

DVD player

using with TV remote control 65

with A/V connectors, connecting 22

with component video connectors, connecting  
21

DVD TITLE button 6

## E

ENTER button 5

EXIT button 5

## F

Factory Reset, setting 60

Fast-forward button 6

Favorite Channel

clearing 36

editing 52

---

## Index

- exiting 35
- using 34–36
- features 2
- Fixed, Audio Output setting 49
- FREEZE button 4, 41
- Freeze, using 41
- frequently asked questions 7
- front panel controls, described 10
- Full mode, setting 50
- FUNCTION buttons 5

## G

- Game, Picture Mode setting 46
- Guide
  - exiting 32
  - using 32
- GUIDE button 5, 32

## H

- HD/DVD IN (1080i/720p/480p/480i) jacks,  
    described 11
- Hide setting, in i.LINK Setup 59
- hue, adjusting 47

## I

- i.LINK
  - cables 25
  - daisy-chaining devices 27
  - equipped devices, connecting 2, 25
  - setup screens 28
- i.LINK button 4, 10
- i.LINK S200 jacks, described 11
- i.LINK Setup 59
- i.LINK Standby 10, 59
- INDEX button 4, 33

## J

- joystick 4
- JUMP button 5

## L

- labels, assigning to video inputs 59
- Language, setting 59
- logos, assigning to channels 53

## M

- MDP, using with TV remote control 66
- MENU button 4, 6, 10
- menus
  - Audio 45, 48
  - Channel Setup 45, 52
  - Parental Control 45, 54
  - Screen Mode 45, 50
  - Setup 45, 58
  - Video 45, 46
- Mono setting 49
- Movie, Picture Mode setting 46
- MTS setting 49
- MTS/SAP button 5
- MUTING button 4

## N

- Normal mode, setting 50

## O

- off, turning off the DTV 5, 10
- on, turning on the DTV 5, 10
- Optical IN-equipped devices, connecting 24
- OPTICAL OUTPUT (Dolby Digital/PCM) jack,  
    described 11

## P

- Parental Control menu 45, 54
- parental control, described 2
- Parental Lock, setting 55
- password, changing 55
- Pause button 6
- PIC MODE button 4
- picture contrast, adjusting 46
- picture definition, setting 47
- Picture Mode, setting 46
- Play button 6
- POWER button 5, 6, 10
- power cord, removing from holder 9
- powering on/off, the DTV 5, 10
- presetting channels 52
- Pro, Picture Mode setting 46
- problems, troubleshooting 68–69
- Program Guide, see Guide

**R**

ratings, setting 54–57  
ratings, viewing blocked programs 57  
rear panel connectors, described 11  
Record buttons 6  
remote control  
    inserting batteries 3  
    programming 62–64  
RESET button 4  
resetting  
    Audio options 48  
    Video options 46  
resetting settings 60  
Rewind button 6

**S**

S VIDEO jack, described 10, 11  
SAT/CABLE button 5  
satellite receiver  
    connecting, with VCR 19  
    using with TV remote control 66  
Screen Mode menu 45, 50  
Scrolling Index, using 33  
SELECT button 10  
SELECT OUT jacks, described 11  
Select Out, setting 58  
setting up 30  
Setup menu 45, 58  
sharpness, adjusting 47  
Show setting, in i.LINK Setup 59  
signal, displaying strength 53  
Simulated, Effect 48  
SLEEP button 4  
Speaker setting 49  
speakers  
    turning on/off 49  
    using external speakers 49  
specifications 70  
Standard, Picture Mode setting 46  
STANDBY/i.LINK STANDBY 10  
Steady Sound, described 2  
Steady Sound, setting 48  
Stereo setting 49  
Stop button 6  
SURF FAVORITE button 5, 35

**T**

tape-to-tape editing 17  
Tilt Correction, setting 60  
tilt, correcting 60  
TIMER button 5  
Timer Setup 60  
transport buttons 6  
treble, adjusting 48  
troubleshooting 68–69  
TruSurround, Effect 48  
turning on/off the DTV 5, 10  
TV/VCR button 6  
TV/VIDEO button 5, 10  
Twin View  
    described 2  
    using 38–40  
Twin View button 5

**V**

Variable, Audio Output setting 49  
VCR  
    connecting two, for tape editing 17  
    using with TV remote control 65  
    with cable box, connecting 15  
    with cable, connecting 14  
    with satellite receiver, connecting 19  
Velocity Modulation 2  
Velocity Modulation, setting 47  
Vertical Center, adjusting 51  
Vertical Correction, setting 60  
Vertical Size, adjusting 51  
VHF/UHF jack, described 11  
VIDEO (L/R)/AUDIO jacks, described 10, 11  
Video Input, setting 59  
Video menu 45, 46  
Vivid, Picture Mode setting 46  
VOL buttons 4, 10  
volume, adjusting 4

**W**

Wega, described 1  
Welcome screen 30  
what is digital TV? 7  
Wide Mode 50  
WIDE MODE button 4  
Wide Screen mode 37

---

*Index*

Wide Screen, described 2

Wide Zoom mode, setting 50

**Z**

zoom feature, with Twin View 40

Zoom mode, setting 50